

People's Democratic Republic of Algeria

Ministry of Higher Education and Scientific
Research

University of Bordj Bou Arreridj
Faculty of Science and Technology



Department of Civil
Engineering

Specialization: Structures

Thesis

Submitted in view of obtaining the Diploma of Civil Engineer

Entitled

**Study of a mixt multi-story Building (G+6) with
Reinforced Concrete**

Presented by: SAOUD Mohammed.

YESSAAD Zitouni.

Supervisor: LOUMACHI Lazhar.

Jury members

Dr ABDEMEZIANE Nabil *President* UNIVERSITY of BBA

Dr LOUMACHI Lazhar *Supervisor* UNIVERSITY of BBA MCD

Dr DJOUDI Larbi *Examiner* UNIVERSITY of BBA

Dr LOGZIT Nacer *Examiner* UNIVERSITY of BBA

University Year: 2023/2024

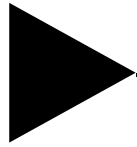

Thanks, and Gratitude

We thank God Almighty first and foremost for the great grace that He has bestowed upon us, then we thank those who favored them.

We express our deep gratitude to our supervisor Doctor LOUMACHI Lazhar for giving us the chance to archive this thesis, for the confidence he has shown in us, and for his help and constructive advices. And thank the whole department of civil engineering.

And we express our gratitude and thanks to the dean of the faculty doctor AMMAR Noui and Chief Head of Civil Engineering Department doctor ABD ELLATIF Belouadah.

Finally, we want to express our gratitude to every person and friend who contributed in the development of this thesis, in particular our families for the sacrifices they made so that we were finishing our studies, and our colleagues and friends who have given us support during these years of work.

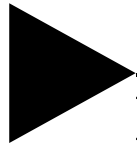

DEDICATION

To my dearest parents who guided me during my life until I reached this stage

To the light of my life, the woman who carried me nine months in der womb, the magnificent woman who made me who I am today, my beloved mother MOUNA FATIHA.

To my strength and security, my happiness and purity, my dear father ACHOUR SAOUD

To all my family not all the words can express my gratitude respect love and affection

To all my dear friends and my colleagues in the class 2023/2024

Mohammed

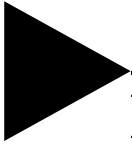

DEDICATION

To all my family not all the words can express my gratitude respect love
and affection

To my beautiful daughter little angle

To all my dear friends and my colleagues in the class 2023/2024

Zitouni

الملخص

في هذا العمل نقدم لكم دراسة و تحليل متعمق لمبنى خرساني مسلح للإستخدامات المتعددة (التجارية و السكنية) يتكون من طابق أرضي بالإضافة إلى ستة طوابق، يقع في ولاية البويرة بمدينة سور الغزلان التي تعتبر منطقة ذات نشاط زلزالي متوسط حسب خريطة النشاط الزلزالي في الجزائر و إستنادا إلى معايير البناء و الوثائق التقنية الجزائرية .

الدراسة الديناميكية للبناء تمت بواسطة برنامج ETABS V 20.3 الذي يعتمد على طريقة العناصر المنتهية ، و تم حساب القوى الناتجة عن العناصر الهيكلية المختلفة باستخدام طريقة طيف الأنماط المتطابقة . سمحت لنا نتائج هذه الدراسة بتحديد أبعاد العناصر الهيكلية و كمية التسليح اللازمة للاستقرار و مقاومة الزلازل الكلمات المفتاحية:

البناء ، التسليح ، الخرسانة المسلحة ، طيف الأنماط المتطابقة ، الإستقرار ، العناصر المنتهية ،

ETABSV20.3

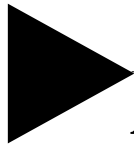

ABSTRACT

In this work, we present an in-depth study and analysis of a reinforced concrete building for multiple uses (commercial and residential) consisting of ground floor plus six floors, located in the wilaya of Bouira, Sour El Ghozlane city which is considered as a zone of medium seismic activity according to the Algerian seismic hazard map and based on Algerian construction standards and technical documents.

The dynamic study of the structure was determined by ETABS V 20.3 software which is based on the finite elements method, and the forces resulting in the various structural elements were calculated using spectral modal method.

The results of this study allowed us to determine the dimensions of structural elements and the amount of reinforcement necessary for stability and resistance to earthquakes.

Keywords:

Building, reinforcement, reinforced concrete, spectral modal method, stability, finite elements method, ETABS V 20.3.

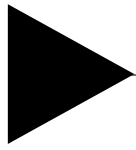

RÉSUMÉ

Dans ce travail, nous vous présentons une étude approfondie et une analyse d'un bâtiment en béton armé à usages multiples (commercial et résidentiel) composé d'un rez-de-chaussée plus six étages, situé dans la wilaya de Bouira, ville de Sour El Ghozlane qui est considérée comme une zone d'activité sismique moyenne selon la carte de l'aléa sismique algérien et basée sur les normes de construction algériennes et les documents techniques.

L'étude dynamique de la structure a été déterminée par le logiciel ETABS V 20.3 qui est basé sur la méthode des éléments finis, et les forces résultant des différents éléments structurels ont été calculées à l'aide de la méthode modale spectrale.

Les résultats de cette étude nous ont permis de déterminer les dimensions des éléments structurels et la quantité de ferrailage nécessaire pour la stabilité et la résistance aux séismes.

Mots clé :

Bâtiment, ferrailage, Béton armé, méthode modale spectrale, stabilité, méthode des éléments finis, ETABS V 20.3.



CONTENTS:

LIST OF FIGURES

LIST OF TABLES

LIST OF ABBREVIATIONS

GENERAL INTRODUCTION

I	Presentation and General Information about the project	1
I.1	Introduction:.....	2
I.2	Presentation of the Project:	2
I.2.1	Geotechnical characteristics of the site:	3
I.2.2	Geometric data of the structure:	3
I.2.3	The design of the building structure:	4
I.2.4	Rules and standards of calculation:	4
I.3	Materials characteristics:	7
I.3.1	Introduction:	7
I.3.2	Concrete:	8
I.3.3	Reinforcement steel:	14
I.4	Conclusion:	16
II	Pre-dimensioning of the elements:	17
II.1	Introduction:.....	18
II.2	Pre-sizing of elements:.....	18
II.2.1	The floors:.....	18
II.2.2	Beams:	21
II.2.3	The Columns:.....	23
II.2.4	Sear walls:.....	23
II.2.5	Stairs:	24
II.2.6	Parapet wall:	27
III	Evaluation of the loads:	29
III.1	Load assessment:.....	30
III.1.1	Load assessment for inaccessible Terrace:.....	30
III.1.2	Assessment of the load of common Floor:	31
III.1.3	Load assessment of the loads of Masonry:.....	32
III.1.4	Assessment for the balconies:.....	32
III.1.5	Assessment loads for the staircase:	33
III.1.6	Assessment loads for parapet wall:	34
III.2	Law of degression loads:	34
III.2.1	Operating loads:.....	35

III.2.2	Application example of the loads descent:	35
III.2.3	Verification of column section (45×45):	43
IV	Study of secondary elements:	45
IV.1	Introduction:	46
IV.2	Study of the parapet:.....	46
IV.2.1	Calculation principal:	46
IV.2.2	Assessment of loads for the parapet:.....	47
IV.2.3	Combination of loads:	47
IV.2.4	Reinforcement calculation:.....	48
IV.3	Dimensioning of hollow body floors:	53
IV.3.1	Definition:	53
IV.3.2	Calculation of load-bearing elements of the hollow-body floor:	54
IV.4	Staircase dimensioning:.....	68
IV.4.1	Calculation hypothesis:	68
IV.4.2	Evaluation of loads and over loads for 1 ml:	68
IV.4.3	Calculation of the staircase:	69
IV.4.4	Reinforcement:	70
IV.4.5	Verification S.L.S:	72
IV.5	Study of Machine slab:.....	79
IV.5.1	Study of the Elevator:.....	80
IV.5.2	Calculation of reinforcement direction X-X:	84
IV.5.3	Calculation of reinforcement direction Y-Y:	85
IV.5.4	Verification S.L.S:.....	86
IV.6	Study of the balconies:	87
IV.6.1	Load assessment:.....	87
IV.6.2	Load combinations:	88
IV.6.3	Embedding moment:	88
IV.6.4	Calculation of reinforcement:.....	89
IV.6.5	Verification S.L.S:.....	89
V	Dynamic analysis:	92
V.1	Introduction:	93
V.2	Calculation methods:	93
V.3	Modulization:.....	93
V.3.1	Modeling approach on the ETABS software:.....	94
V.4	Classification criteria by RPA99V2003:	98
V.4.1	Classification of seismic zones:.....	98
V.4.2	Classification of structures according to their importance:	98
V.4.3	Site classification:	99
V.4.4	Classification of bracing systems:	99
V.5	Static equivalent method:	99
V.5.1	Calculation of seismic force:	101
V.6	Response spectrum method:	107
V.6.1	Modeling:.....	107

V.6.2	Calculated response spectrum:	107
V.6.3	Number of modes to consider:.....	109
V.6.4	Justification for estimating the fundamental period:	111
V.6.5	Effects of accidental torsion:	111
V.6.6	The arrangement of the sails:	112
V.6.7	Results of dynamic analysis by ETABS:.....	113
V.7	Requirements common to methods "static" and "dynamic":.....	114
V.7.1	Justification of the choice of shear walls:.....	114
V.7.2	Verification of renversement stability:	114
V.7.3	Calculation of displacements:.....	115
V.7.4	Verification of the effect $P - \Delta$:	119
V.7.5	Verification of reduced normal effort N:.....	122
V.8	Conclusion:.....	122
VI	Reinforcement of structural elements:.....	123
VI.1	Introduction:	124
VI.2	Reinforcements of the beams:	124
VI.2.1	Combination of reinforcement of beams:	124
VI.2.2	Various regulatory recommendation and requirements for beams:	124
VI.2.3	Calculation of main beams:	125
VI.2.3.1	Longitudinal reinforcements:	126
VI.2.3.2	Verification required:	128
VI.2.3.3	Transverse reinforcements:	130
VI.2.3.4	Verification of shear force:	130
VI.2.3.5	Service limit status check:.....	131
VI.2.3.6	Shema Reinforcement:	132
VI.2.4	Calculation of secondary beams:.....	133
VI.2.4.1	Longitudinal reinforcements:	131
VI.2.4.2	Verification required:	136
VI.2.4.3	Transverse reinforcements:	137
VI.2.4.4	Verification of shear force:	138
VI.2.4.5	Service limit status check:.....	138
VI.2.4.6	Shema Reinforcement:	139
VI.3	Reinforcement of columns:	140
VI.3.1	Combination of loads:	140
VI.3.2	Various regulatory recommendation for columns:.....	140
VI.3.2.1	Longitudinal reinforcements :	140
VI.3.2.2	Transverse reinforcements:	141
VI.3.3	Solicitations in the column:.....	141
VI.3.3.1	Column (45×45):	141
VI.3.4	Verification required:	147
VI.3.5	Transversal reinforcement:	149
VI.3.6	Verification the shear force:.....	149
VI.3.7	Shema reinforcement:	150

VI.4 Reinforcements of the walls:	151
VI.4.1 Introduction :	151
VI.4.2 Combination :	151
VI.4.3 Calculation principle :	151
VI.4.4 Calculation method:	151
VI.4.5 Walls reinforcement:	153
VI.4.6 Shema of reinforcement:	158
VII Reinforcement of structural elements:	159
VII.1 Introduction:	160
VII.2 Foundation choice:	160
VII.3 Study of isolated footing:	160
VII.3.1 Calculation example:	161
VII.4 Study of Strip footing under walls:	163
VII.4.1 Calculation example:	163
VII.5 Study of the Sill:	165
VII.5.1 Dimensions of the Sill:	165
VII.5.2 Reinforcement of the Sill:	165



LIST OF FIGURES:

Figure I.1 Plan of the structure.....	2
Figure I.2 Dimension plan.....	2
Figure I.3 Floor hollow block	4
Figure I.4 Solid slab floor	4
Figure I.5 Rectangular beam	5
Figure I.6 Rectangular column.....	5
Figure I.7 Exterior wall	6
Figure I.8 Parapet	6
Figure I.9 Foundation.....	7
Figure I.10 Evolution of the resistance f_{cj} as a function of the age of the concrete	10
Figure I.11 Development of tensile strength f_{tj} as a function of that at compression f_{cj} ...	10
Figure I.12 Strain-stress diagram of concrete at ULS	12
Figure I.13 Strain-stress diagram of concrete at SLS.....	13
Figure I.14 Simplified rectangular diagram	13
Figure I.15 Strain-stress diagram of steel.....	15
Figure II.1 Floor hollow block	18
Figure II.2 Cross section of hollow body floor	19
Figure II.3 The cross section of the rib	20
Figure II.4 Solid slab	21
Figure II.5 Cross section of the main beam	22
Figure II.6 Cross section of the secondary beam	22
Figure II.7 Representation of the column most used	23
Figure II.8 Sear wall.....	24
Figure II.9 The components of two-flight staircase	25
Figure II.10 Schema of bench	26
Figure II.11 Cross section of the secondary beam	27
Figure II.12 Parapet wall schema.....	28
Figure III.1 Central column.....	35
Figure III.2 Corner column	38
Figure III.3 Edge column	38
Figure IV.1 Action on the parapet.....	48
Figure IV.2 Reinforcement section (Parapet)	50
Figure IV.3 Reinforcement scheme of parapet	53
Figure IV.4 Arrangement of the compression slab reinforcement.....	54
Figure IV.5 Type of girder	57
Figure IV.6 Reinforcement of the girder.....	68
Figure IV.7 Reinforcement of the staircase	78

Figure IV.8 Reinforcement of the landing beam.....	78
Figure IV.9 Schema of an elevator.....	79
Figure IV.10 Dimensions of the balcony	88
Figure IV.11 Reinforcement of the balcony.....	91
Figure V.1 Programme of modulization	93
Figure V.2 Defining a new model.....	94
Figure V.3 Set up grid lines and define story levels	94
Figure V.4 Editing the grid	94
Figure V.5 Define materials	95
Figure V.6 Define the sections.....	95
Figure V.7 Definition of loads	96
Figure V.8 Definition of the different combinations.....	96
Figure V.9 Definitions of diaphragms.....	97
Figure V.10 Structure modulization.....	97
Figure V.11 Classification of seismic zones	98
Figure V.22 Response spectrum parameters direction x.....	108
Figure V.33 Response spectrum parameters direction y.....	108
Figure V.44 Response spectrum direction x and y.....	108
Figure V.55 View mode 1 Translation in direction x-x	110
Figure V.66 View mode 2 Translation in direction y-y	110
Figure V.17 View mode 3 Rotation	111
Figure V.18 The arrangement of the sails in 3D.....	112
Figure V.19 The arrangement of the sails in plan.....	112
Figure V.20 Element forces for columns	122
FigureVI.1 The Poisson's coefficient at ULS	126
FigureVI.2 The Poisson's coefficient at SLS	126
Figure VI.3 Reinforcement on support -Main beam-.....	132
Figure VI.4 Reinforcement on span-Main beam-	132
FigureVI.5 The Poisson's coefficient at ULS.....	133
FigureVI.6 The Poisson's coefficient at SLS	133
Figure VI.7 Reinforcement on support -Secondary beam-	139
Figure VI.8 Reinforcement on span -Secondary beam-.....	139
Figure VI. 9 Reinforcement of column 45×45	150
FigureVI.20 Reinforcement of wall	158
FigureVII.1 Reinforcement of isolated footing.....	163
FigureVII.2 Reinforcement of Strip footing	164
FigureVII.3 Reinforcement of the sill.....	165



LIST OF TABLES:

Table I.1	Dimensions of the structure	3
Table I.2	Characteristics of the steels used	14
Table III.1	Load assessment for inaccessible Terrace (Floor hollow block)	30
Table III.2	Load assessment for inaccessible Terrace (Solid slab floor)	30
Table III.3	Assessment of the load of common Floor (Floor hollow block)	31
Table III.4	Assessment of the load of common Floor (Solid slab floor)	31
Table III.5	Assessment of the loads of Masonry (External wall)	32
Table III.6	Assessment of the loads of Masonry (Interior wall)	32
Table III.7	Assessment of the loads of balconies	32
Table III.8	Assessment of the loads of balconies (guardrail load)	33
Table III.9	Load assessment for the staircase (Landing)	33
Table III.10	Load assessment for the staircase (Bench)	33
Table III.11	Assessment loads for parapet wall	34
Table III.12	Degression operating loads by level	35
Table III.13	Results of lowering loads from the central column	36
Table III.14	Results of lowering loads from the Corner column	39
Table III.15	Results of lowering loads from the Edge column	41
Table III.16	Verification the section of all types column	44
Table IV.1	Loads and overloads	58
Table IV.2	The maximum stresses in the grider	64
Table IV.3	Evaluation of loads of staircase	69
Table IV.4	Main reinforcements of staircase	72
Table IV.5	Load assessment of the machine slab	81
Table V.2	Centers of mass and rigidity	100
Table V.3	Acceleration coefficient of the zone (A)	102
Table V.4	Value of ξ	102
Table V.5	Value of T_1 and T_2	103
Table V.6	Value of P_q for the direction x-x	104
Table V.7	Value of P_q for the direction y-y	105
Table V.7	Mass summary by story	106
Table V.8	Number of modes	109
Table V.9	Verification of the fundamental period	111
Table V.10	Seismic computing forces	113
Table V.11	Seismic computing forces	114
Table V.12	The moments of renversement	114
Table V.13	The moments of stability	115
Table V.14	Maximum Story Displacement under force E_x	116
Table V.15	Maximum Story Displacement under force E_y	116

Table V.16 The effect $P - \Delta$ in direction x.....	119
Table V.17 The effect $P - \Delta$ in direction y.....	119
Table VI.1 Maximum loads for main beams.....	126
Table VI.2 Maximum loads for secondary beams	133
Table IV.3 Solicitations in the column from Etabs2022.....	141
Table IV.4 The other accidental cases of column	146
Table VI.5 Reinforcement section of columns 45×45.....	146
Table IV.6 The different solicitations of wall	153



LIST OF ABBREVIATIONS:

- A: Zone acceleration coefficient.
 A_a : Supporting reinforcement section.
 A_l : Longitudinal reinforcement section.
 A_{min} : Minimum reinforcement section determined by the regulations.
 A_r : Distribution reinforcement section.
 A_{ser} : Serviceability limit state reinforcement section.
 A_t : Span or transverse reinforcement section.
 A_u : Ultimate limit state reinforcement section.
 A_x : Reinforcing section in direction x-x.
 A_y : Reinforcing section in y-y direction.
A': Compression reinforcement section.
 A_l : Section of the tensest or least compressed reinforcement.
 A_2 : Least stretched or most compressed section of the reinforcement.
B: Area of concrete section.
 B_r : Reduced section of the concrete.
CV: Conduction verified.
 C_p : Horizontal force factor.
 C_s : Safety coefficient.
 C_r : Breaking load.
 C_{rn} : Minimum breaking load required.
D : Dynamic amplification coefficient.
E : Longitudinal deformation modulus.
 E_s : Young's modulus of steel.
 E_{ij} : Instant Young's module at the age of d days.
 E_{vj} : Young's module differs at the age of d days.
F: Force or action in general.
G: Permanent action (dead load).
H: height.
HA: High grip reinforcement.
I: Moment of inertia.
L: Length.
 L_e : Elevation length.
 L_n : Distance between ribs.
 L_p : Plan length.
M: Bending moment
 M_a : Bending moment in support.
 M_c : Center bending moment.
 M_d : Right bending moment.
 M_e : Moment at the center of the section.

M_f : Total bending moment.
 M_j : Bending moment under permanent load before installation of partitions.
MI: Linear mass.
 M_{ser} : Serviceability limit state bending moment.
 M_t : Span bending moment.
 M_u : Ultimate limit state bending moment of resistance.
 M_w : Left bending moment.
 M_x : Bending moment in direction x-x.
 M_y : Bending moment of y-y direction.
N: Normal effort.
 N_{ser} : Serviceability limit state normal force.
 N_u : ultimate strength limit state normal force.
P: Proper weight or Perimeter.
Q: Any variable action or Quality factor.
R: Radius or Structural behavior coefficient.
S: Surface.
SLS: Service limit state
T: Shear force.
 T_x : Fundamental period in x-x direction.
 T_y : fundamental period in y-y direction.
ULS: Ultimate limit state.
V: Seismic action or Horizontal effort.
 V_t : Seismic force at the base of the structure.
W: Total weight of the structure.
 W_p : Weight of the element in consideration.
a: Length or Distance or Dimension.
b: Length.
 b_0 : Rib width.
 b_1 : Column width.
c: Coating.
d: Usable height.
e: Eccentricity or Spacing or Thickness.
 e_a : Additional eccentricity.
f: Arrow.
 f_c : Characteristic stress of concrete in compression.
 f_e : steel elastic limit.
 f_t : Characteristic stress of concrete in tension.
g: Lap of the walk.
h: Height.
 h_c : Hollow body height.
 h_d : Slab height.
 h_e : Clear height.
 h_{moy} : Average height.
 h_t : Total height.
 h' : Nodal zone height.

h_1 : Height of column.
 i : radius of gyration.
 l : length or distance.
 l_f : Buckling length.
 l_x : The small dimension of the slab panel.
 l_y : The large dimension of the slab panel.
 l' : Nodal zone length.
 l_0 : Free length.
 q_{ser} : Serviceability limit state linear load.
 q_u : Resistance ultimate limit state linear load.
 q_p : Bearing linear load.
 s : Spacing.
 t : Spacing or Period.
 α : Angle, dimensionless coefficient.
 γ : Partial safety factor, ratio of moments.
 β : Dimensionless coefficient, weighting coefficient.
 ε : Response factor.
 η : Relative cracking coefficient, damping correction factor.
 θ : Angle, dimensionless coefficient, global coefficient depending on the type of construction.
 λ : Mechanical slenderness of a compressed element, dimensionless coefficient, aspect ratio.
 μ : Reduced moment.
 ν : Poisson coefficient.
 ρ : Ratio of two dimensions.
 σ : Concrete or steel stress.
 τ : Tangential or shear stress.
 ψ : Weighting coefficient
 ζ : Critical Damping Percentage.
 δ : Reduction coefficient, spacing of traverse reinforcement.

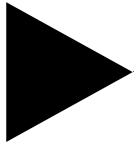

GENERAL INTRODUCTION

Civil engineering is a professional engineering discipline that focuses on the design and planning constructions of buildings. And it representing all techniques related to construction in order to ensure the stability and resistance of buildings.

Civil engineers play a crucial role in the design of structures and systems especially in vertical construction in order to withstand natural disasters such as flood and earthquakes.

Earthquakes pose significant dangers to both human life and constructions due to their sudden and often violent nature. it is unfortunately certain that earthquakes will continue to surprise humans

To produce resistant elements, it is necessary to follow various calculation methods according to the different parameters, The calculation was carried out according to standards and regulatory documents which are (RPA99V2003) and regulations (CBA93).

For this project, we calculated a building located in a zone of medium seismicity (IIa), with a ground floor plus 6 floors (G + 6), it aims to size the structures in a resistant and economical way.

- **The first chapter:** consists of the complete presentation of the building, the definition of the different elements and the choice of materials to be used.
- **The second chapter:** presents the pre-dimensioning of the elements (Columns, beams and walls...).
- **The third chapter:** Evaluation of the loads.
- **The fourth chapter:** Study of secondary elements (the parapet, the stairs, floors).
- **The fifth chapter** will deal with the dynamic study of the building.
- **Chapter Six:** calculation of reinforcements of structural elements, based on the results of the ETABS 22 software.
- **Chapter seven:** the calculation and sizing of the infrastructure for determining the type of foundations.

Chapter

I

Chapter I

**Presentation and General Information
about the project:**

I.1 Introduction:

The construction of multi-storey buildings represents a harmonious combination of engineering precision and architectural vision. Among the various building materials available, reinforced concrete stands as a hallmark of structural strength and versatility.

In Algeria's dynamic landscape of urban development, the construction of multi-storey buildings stands as an important demonstration of modern engineering ingenuity. The use of reinforced concrete as a primary structural material in such constructions represents a combination of tradition and innovation, ensuring the durability and stability of the structure.

The stability of the structure also depends on the resistance of different structural elements (columns, beams, walls, etc.) to different pressures (pressure, bending, etc.), whose strength depends on the type, dimensions and properties of the materials used.

Therefore, to calculate the structural components, we rely on known regulations and methods (BAEL91, RPA99 modified in 2003, CBA93, DTR) which are based on knowledge of materials (concrete and steel) and dimensions and reinforcement of structural resistant elements.

I.2 Presentation of the Project:

In our project we are making a study and calculation of the resistant elements of a multi-use building (G+6) consisting of:

- A ground floor for offices.
- From the 1st to the 6th floor for residential use.

The building will be located in BOUIRA commune of SOUR EL GHOZLANE classified according to the Algerian seismic regulation (RPA 99 / version 2003) as a zone of medium seismicity (Zone IIa).

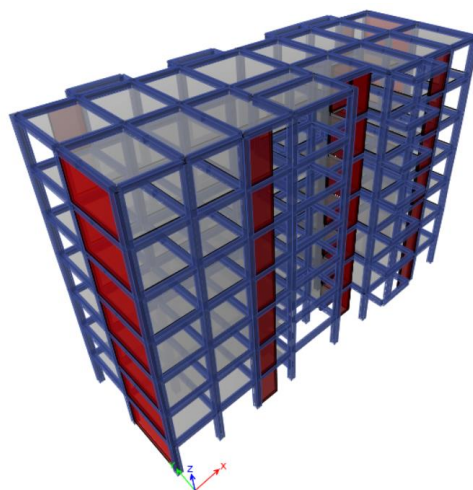

Figure I.1 Plan of the structure

I.2.1 Geotechnical characteristics of the site:

- Our building will be established on soil with admissible stress of: 2.2 bar.
- The site is considered S2 according to RPA99.V2003.
- The group of use 1A.

I.2.2 Geometric data of the structure:

The geometric characteristics of the building are:

Table I.1 Dimensions of the structure

Dimension	By (m)
Length in plan	29.5
Width in plan	12.7
Ground floor height	3.06
Current floor height	3.06
Total height	21.42

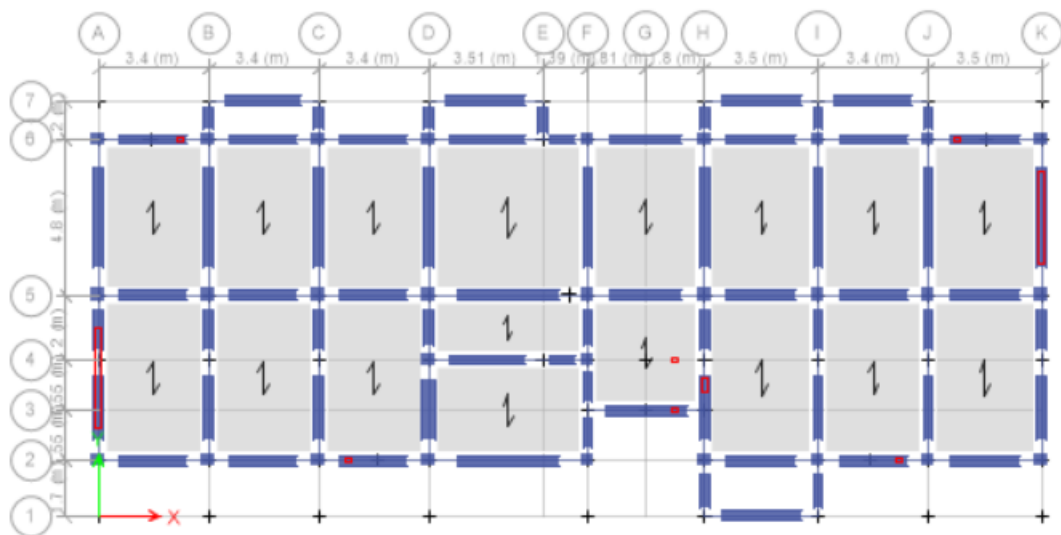

Figure I.2 Dimension plan

I.2.3 The design of the building structure:

I.2.3.1 Bracing structure: (RPA99V2003 article 3.4)

This building is a mixed-bracing consists of walls (intended on the one hand to take back part of the vertical loads and on the other hand have ensured the stability of the structures) and gantries (intended primarily to take up loads and vertical loads) with justification of gantry-wall interaction.

I.2.3.2 Slabs:

In our structure there are two types of slabs:

- a-The floors are made of hollow block and a compression slab (20+5) cm, and girder made of cast-in-place concrete spaced 65 cm from hollow block.
- b-The solid slabs are made of cast-in-place concrete.
- The terrace is inaccessible.

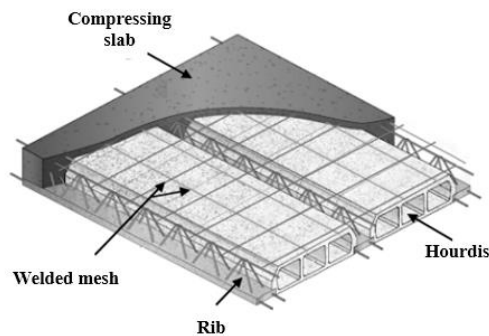

Figure I.3 Floor hollow block

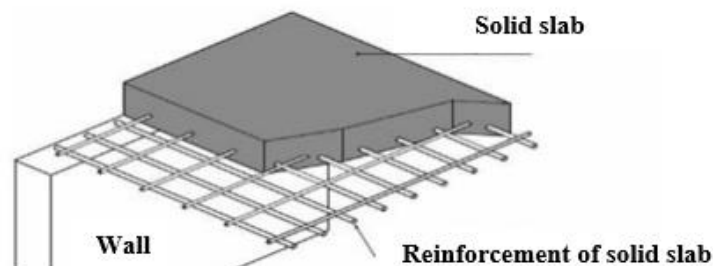

Figure I.4 Solid slab floor

I.2.3.3 Beams:

They are horizontal structural element designed to support loads by resisting bending. Beams are fundamental components of structures, providing support for floors, roofs, ceilings, and other elements, they also made for transmitting the loads from slabs to columns.

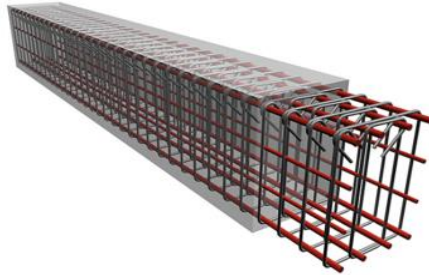

Figure I.5 Rectangular beam

I.2.3.4 Columns:

The columns are vertical constructive elements that links the stories and support compressive loads in buildings and structures. They are designed to transfer the load from the beams, slabs, and other structural elements above them to the foundation below. Columns are crucial components in the structural system of a building, providing stability and strength to the overall structure.

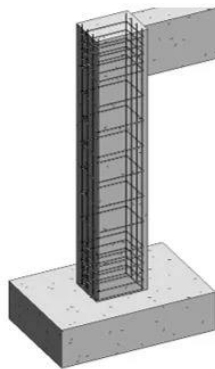

Figure I.6 Rectangular column

I.2.3.5 Staircase:

A staircase is a structure that provides a means of vertical movement between different levels of a building or structure.

I.2.3.6 Masonry:

- Exterior walls: They are made of double partitions of hollow bricks 10 cm + 10 cm spaced with a 5 cm emptiness (10+5+10) cm for thermal and sound insulation.

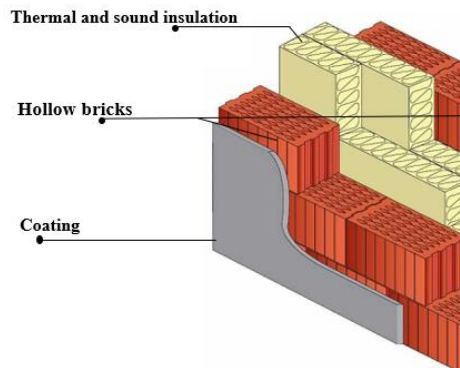

Figure I.7 Exterior wall

- Interior walls: It is single partition made of 10 cm hollow bricks.

I.2.3.7 Coating:

The covering of the building composed of:

- Tiling for floors and staircases and balconies.
- Plaster coating for interior walls and ceilings.
- Mortar cement for plastering of exterior facades.

I.2.3.8 Parapet:

The terrace being inaccessible, the last level is surrounded by a reinforced concrete parapet of height varying between 60 cm and 100 cm and 10 cm thick.

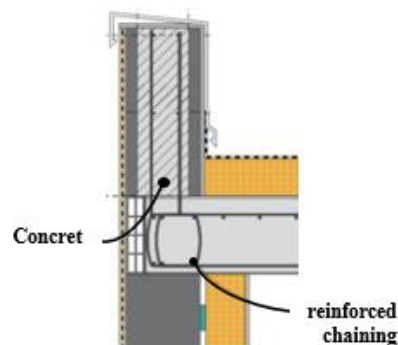

Figure I.8 Parapet

I.2.3.9 Balconies:

The balconies are made of solid reinforced concrete slabs.

I.2.3.10 Foundations:

Foundations are the structural elements of a building or structure that transmit and distribute the loads from the superstructure (above-ground parts) to the underlying soil or rock. The primary function of a foundation is to provide a stable and level base for the construction above it, ensuring that the building remains structurally sound and safe.

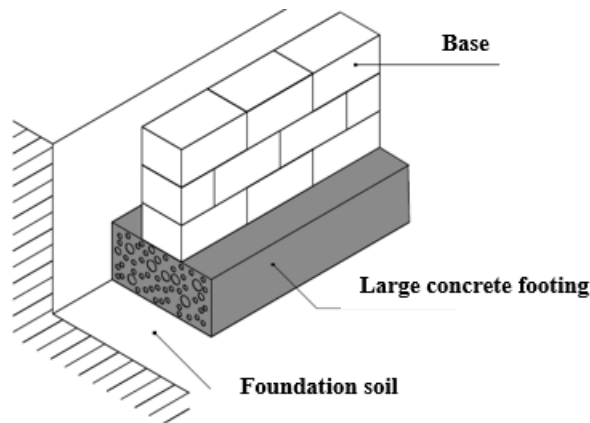

Figure I.9 Foundation

I.2.3.11 Type of formwork used:

The structural elements "Columns, Beams and Sails" are made by formwork metal or wooden formwork, for hollow body floors and stairs, wooden formwork is used.

I.2.4 Rules and standards of calculation:

For calculation and verification, we use:

- Algerian seismic rules (RPA99.V2003).
- The BAEL91 rules.
- Technical regulatory document (DTR-B.C).
- CBA93.
- Software: Finite element modelling of this project using ETABS version 2022.

I.3 Materials characteristics:

I.3.1 Introduction:

Reinforced concrete is a composite material made of concrete reinforced with embedded steel bars or mesh, the combination of concrete's compressive strength and steel's tensile strength creates a highly durable and versatile construction material widely used in various structural applications.

The characteristics of the materials used in construction will comply with the rules technologies for the design and calculation of reinforced concrete structures already mentioned.

I.3.2 Concrete:

Concrete is a versatile construction material composed primarily of cement, water, and aggregates (such as sand, gravel, or crushed stone). It is one of the most widely used construction materials globally due to its durability, strength, and versatility. Here's an overview of concrete:

The cement dosage varies between 300 and 400 kg/ m^3 of concrete used.

I.3.2.1 Composition of the concrete:

It is made up of the following components:

✓ Cement:

Cement is a binder, a powdery material, a chemical substance used for construction that sets, hardens, and adheres to other materials to bind them together.

The cement used a CMEI 42.5, the dosage for the elements of the superstructure is 350 kg/ m^3 .

✓ Sand:

Sand is granular material consisting of small particles from the decay of other rocks whose size is between 0 and 5mm.

-The sand dosage: 400 litre/ m^3

-The weight is: $G_s = \gamma_s \times V_s$

$$G_s = 1.6 \times 400 = 640 \text{ Kg/m}^3$$

γ_s : the density of sand equal 1.6 kg/l

✓ Gravel:

Gravel is a loose aggregation of small stones or pebbles typically derived from natural sources, it is a common construction material used for various applications due to its versatility, durability, and affordability, they consist of rock grains whose size is generally between 7 and 25 to 30mm. They must be hard clean, and not frosty. They may be extracted from the reverbed (rolled material) or obtained by crushing hard rock.

-Aggregate dosing 7/25: 800 litres/ m^3 .

-The weight is: $G_g = \gamma_g \times V_g = 1.5 \times 800 = 1200 \text{ Kg/m}^3$

γ_g : the density of gravel equal 1.5 kg/l.

- The water dosage: is 175 liters/ m^3 .

There are several preparation methods based on particle size, including the **DREUX-GORISSE**

method, the obtained concrete will have a density with varies between (2400-2500) kg/m³.

I.3.2.2 The realization and benefits of concrete:

The realization of structural element in reinforced concrete, includes 4 steps:

- Execution of a formwork (mould) in wood or metal.
- Installation of reinforcements in the formwork.
- Placing and tightening concrete in the formwork.
- Stripping or demoulding after sufficient hardening of the concrete.

The main benefits of concrete are:

- Economics.
- Easy to shape.
- Weather resistance.
- Fire resistance.

On the other hand, the risk of cracking constitutes a handicap for reinforced concrete.

I.3.2.3 Mechanical characteristics:

- **Characteristic compressive strength f_{cj} : (BAEL 91 art A2.1.11).**

The characteristic compressive strength of concrete at “d” days of age is determined at from tests on 16cm x 32cm test pieces.

The 28th day maturity value is most often used: f_{c28} .

For calculations in the implementation, the day-to-day values, defined from f_{c28} , will be adopted by:

- **For $f_{c28} \leq 40$ MPa:**

$$\left\{ \begin{array}{ll} f_{cj} = \frac{j}{4.76+0.83j} \times f_{c28} & \text{si } j < 60 \text{ days} \\ f_{cj} = 1.1 \times f_{c28} & \text{si } j > 60 \text{ days} \end{array} \right.$$

- **For $f_{c28} > 40$ MPa**

$$\left\{ \begin{array}{ll} f_{cj} = \frac{j}{1.40+0.95j} \times f_{c28} & \text{si } j < 28 \text{ days} \\ f_{cj} = f_{c28} & \text{si } j > 28 \text{ days} \end{array} \right.$$

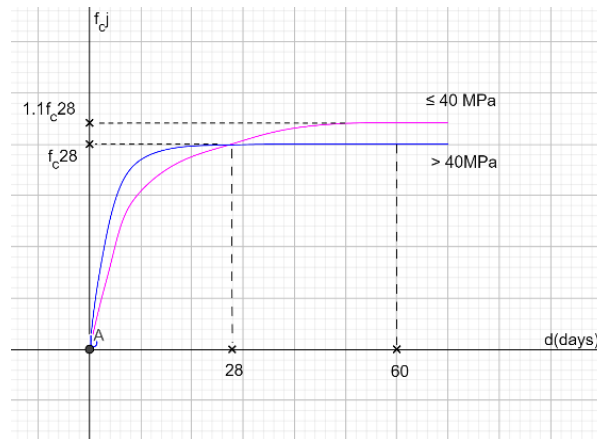

Figure I.10 Evolution of the resistance f_{c_j} as a function of the age of the concrete

- **Tensile strength:** (CBA93 article A.1.2.12)

The tensile strength at age (d) days f_{t_j} is defined by the following formula:

$$f_{t_j} = 0.6 + 0.06f_{c_j} \text{ for } f_{t_j} \leq 60 \text{ MPa}$$

With: $f_{c_{28}} = 25 \text{ MPa}$ and $f_{t_{28}} = 2.1 \text{ MPa}$.

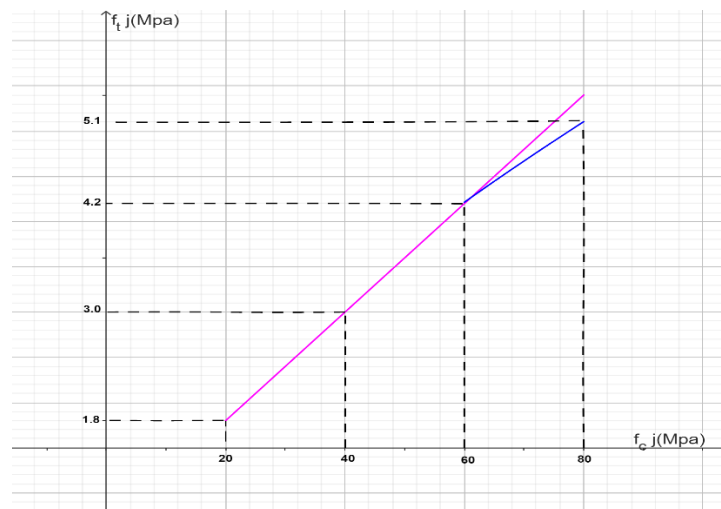

Figure I.11 Development of tensile strength f_{t_j} as a function of that at compression f_{c_j}

- ❖ **Limit state:**

Limit state are known as situations where, if passed, the construction structure is considered ineligible for one of the functions for which it is designed.

- **Ultimate limit state U.L.S:**

It corresponds to the ruin of the structure or one of these elements by loss of static equilibrium, rupture, buckling, that is:

- ✓ Ultimate limit state of static equilibrium without structural reversal.

- ✓ Ultimate limit state of strength for concrete or steel materials example:
(Not broken by crushing concrete).
- ✓ Ultimate limit state of shape stability.

- **Service limit state S.L.S:**

This is the condition that a structure must satisfy for its normal use and durability to be ensured, exceeding it will imply a disorder in the functioning of the structure.

- ✓ Crack opening serviceability limit state.
- ✓ Serviceability limit state of deformation.
- ✓ Serviceability limit state with respect to the compression of the concrete.

I.3.2.4 Deformation and calculation limit stresses: (BAEL 91 art 4.I .3)

- **The instantaneous longitudinal deformation modulus E_{ij} :**

Under normal stress with less than 24 hours of application time, we assume in the absence of measurements, that at the age of “d” days, the instantaneous longitudinal deformation modulus of concrete E_{ij} is equal to:

$$E_{ij} = 11000(f_{cj})^{\frac{1}{3}}$$

where: $E_{ij} = 32164.20 \text{ MPa}$.

- **Deferred longitudinal deformation modulus E_{vj} :**

Under stresses of long-term application, the deferred longitudinal deformation module that calculates the finale deformation of the concrete is given by the formula:

$$E_{vj} = 3700(f_{cj})^{\frac{1}{3}}$$

where: $E_{vj} = 10818.86 \text{ MPa}$.

- **Modulus of elasticity E:**

It is the ratio between the applied stresses and the relative strain:

$$\varepsilon = \frac{\Delta l}{l}$$

This module is not definable in that the elastic phase (one phase) in which there is proportionality of stress and strain.

- **Poisson’s ratio ν : (BAEL 91 art 4.I .3)**

The Poisson ratio is the ratio of the relative lateral strain to the relative axial strain.

$\nu = 0.2$ in the case of service limit state.

$\nu = 0$ in the case of ultimate limit state.

- **U.L.S:**

The ultimate stress of the concrete in compression σ_{bc} is given by the following relationship:

$$\sigma_{bc} = \frac{0.85 \times f_{c28}}{\theta \gamma_b}$$

With:

γ_b : being the safety of concrete, which equals:

$$\gamma_b = \begin{cases} 1.5 & \text{for normal combination} \\ 1.15 & \text{for accidental combination} \end{cases}$$

f_{c28} : characteristic concrete compressive strength at 28 days.

0.85: reduction coefficient which aims to cover the error made by neglecting the creep of the concrete.

θ is a coefficient which takes account of the duration of application of the charges.

$\theta = 1$ if period > 24 h

$\theta = 0,9$ if $1\text{h} \leq \text{period} \leq 24\text{h}$

$\theta = 0,85$ if period < 1 h

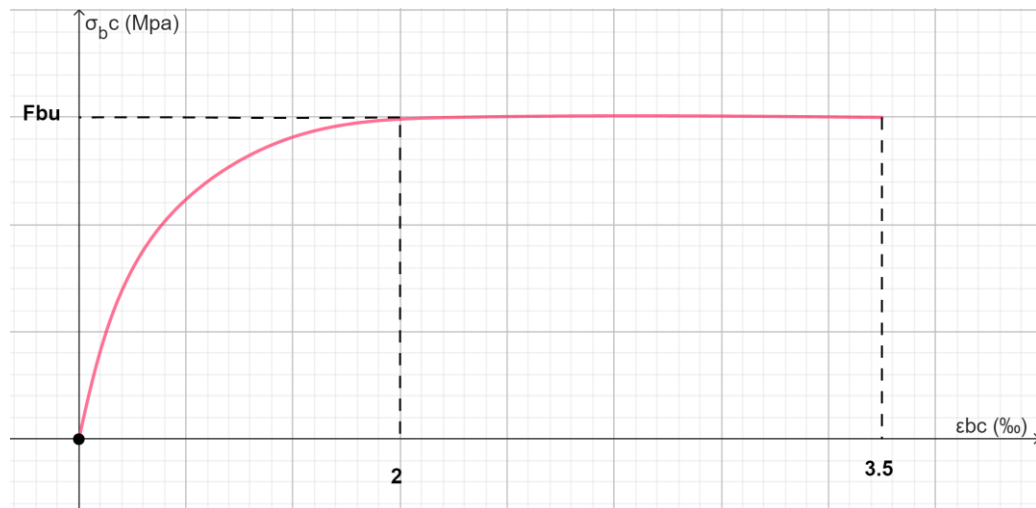

Figure I.12 Strain-stress diagram of concrete at ULS

- **S.L.S:**

The limit stress of the concrete at the service limit state is:

$$\sigma_{bc} = 0.6 \times f_{c28}$$

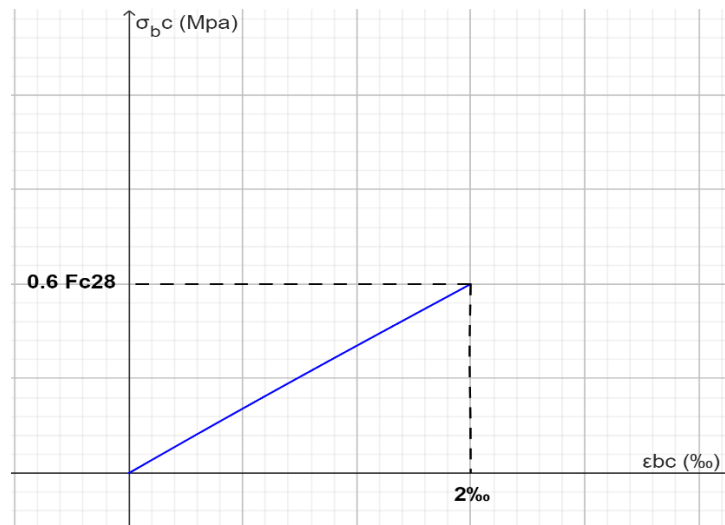

Figure I.13 Strain-stress diagram of concrete at SLS

- Rectangular diagram of concrete: (BAEL 91 art 5.II .2)

When the section is partially compressed, a simplified rectangular diagram can be used:

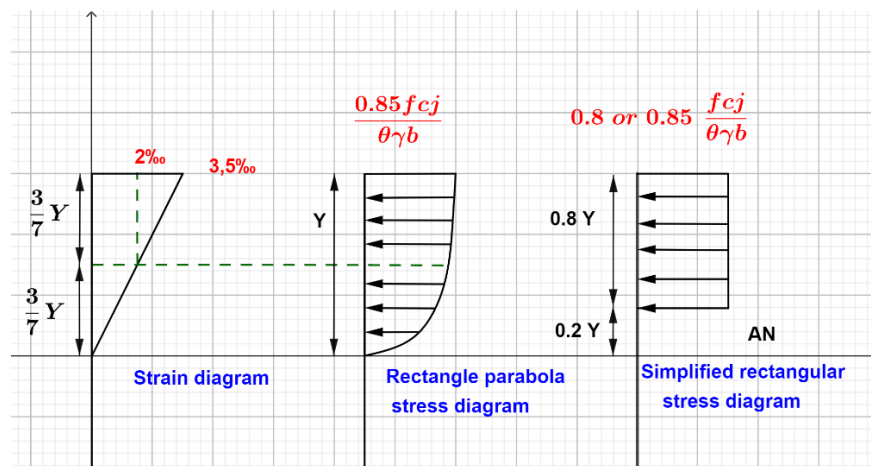

Figure I.14 Simplified rectangular diagram of concrete

- Allowable shear stress: (art 13.III .2.1; BAEL 91)

$$\tau_u = \min (0,2 f_{c28} / \gamma_b, 5\text{MPa}) \Rightarrow \text{Low injury cracking}$$

$$\tau_u = \min (0,15 f_{c28} / \gamma_b, 4\text{MPa}) \Rightarrow \text{Injurious or highly injurious cracking}$$

The ultimate shear stress in a concrete piece is defined in relation to the stress ultimate edge

$$\tau_u = \frac{T_u}{b \times d}$$

b: Piece width.

d: Useful height.

I.3.3 Reinforcement steel:

I.3.3.1 Definition:

A steel is a metal alloy made mainly of iron and carbon.

The steel is intended to balance the tensile forces and possibly compressive forces when the concrete cannot support it alone.

Are characterized by their elastic limits f_e and their modulus of elasticity E.

I.3.3.2 Mechanical characteristics:

Example of steel:

Table I.2 Characteristics of the steels used

Grandes	Fe (MPa)	Utilisation
Fe E400	400	Frame, stirrups pins, column, beam
Fe E235	235	All reinforced concrete works
Fe E500	500	floors

- Longitudinal modulus of elasticity:

The value of the longitudinal modulus of elasticity of the steel is taken equal to:

$$E_s = 200000 \text{ MPa.}$$

- Strain-stress diagram of steel: (BAEL91 art 4.II.2)

In the calculation of limit states, a safety coefficient γ_s is introduced which has the following values:

$$\begin{array}{ll} \gamma_s = 1,15 & \text{general cases} \\ \gamma_s = 1,00 & \text{cases of accidental combinations} \end{array}$$

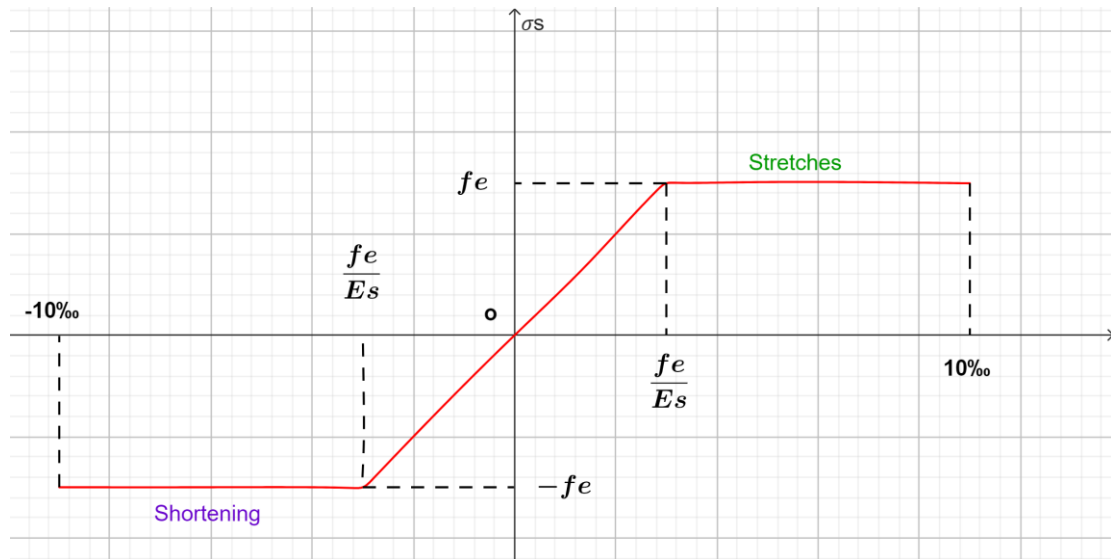

Figure 1.15 Strain-stress diagram of steel

• **Limit stresses: (BAEL91 art 5.IV.3.3)**

➤ **U.L.S:**

$$\sigma_s = \frac{f_e}{\gamma_s} \longrightarrow \text{Natural steels}$$

$$\sigma_s = 1.1 \times \frac{f_e}{\gamma_s} \longrightarrow \text{Hardened steels}$$

With γ_s : safety coefficient depends on type of situation.

$\gamma_s = 1.15$ In current situation $\sigma_s = 348 \text{ MPa}$

$\gamma_s = 1$ In accidental situation $\sigma_s = 400 \text{ MPa}$

➤ **S.L.S:**

The limit stresses of steel σ_s are given according to the limit state of crack opening

- Minimally harmful cracking: no verification

- Detrimental cracking: $\sigma_s = \min \left(\frac{2}{3} f_e, 110 \sqrt{\eta f_{tj}} \right)$

- Very detrimental cracking: $\sigma_s = \min \left(\frac{1}{2} f_e, 90 \sqrt{\eta f_{tj}} \right)$

η : Safety factor depends on adhesion:

$\eta = 1$ For steel (RL)

$\eta = 1.6$ For steel (HA)

I.3.3.3 Actions (loads):

• **Permanent load (Dead loads) G:**

These are actions whose intensity is constant or slightly variable over time, for example the self-

weight of the structure, the weight of fixed equipment, the pushing forces of earth and liquids or the deformations imposed on the structure.

- **Operating load (live loads) Q:**

These are those whose intensity frequently varies significantly over time, they correspond to operation loads, loads applied during execution, climatic loads, and effects due to temperature.

- **Accidental charge E:**

These are those coming from short-term phenomena (earthquakes, explosions, etc.) that rarely occur, requiring dynamic action.

- **Specific combination of calculation:**

- **Fundamental action combination: (CBA 99 article.3.3)**

$$\begin{cases} 1.35G_{\max} + G_{\min} + \gamma_{Q1} Q_1 + \sum 1,3 \psi_{0i} Q_i & \text{for U. L. S} \\ G_{\max} + G_{\min} + Q_1 + \sum \psi_{0i} Q_i & \text{for S. L. S} \end{cases}$$

γ_{Q1} = 1.5 general case.

γ_{Q1} = 1.35 for agricultural buildings with low human occupancy density.

ψ_{0i} : weighting coefficient of the accompanying values, it is equal to 0.77 for the common buildings.

The basic combinations can be interpreted as follows:

$$\begin{cases} 1.35G + 1.5 Q & \text{for U. L. S} \\ G + Q & \text{for S. L. S} \end{cases}$$

- **Accidental combination: (CBA 99 article.3.3.2.2)**

$$\{G_{\max} + G_{\min} + FA + \psi_{11} Q_1 + \sum \psi_{2i} Q_i$$

FA: Nominal value of the accidental action.

ψ_{11} : Frequent value of a variable action.

$\psi_{2i} Q_i$: Quasi-permanent value of another variable action.

In the case of horizontal forces (Earthquakes):

$$\begin{cases} G + Q \pm 1,2 E \\ G + Q \pm E \\ 0,8 G \pm E \end{cases}$$

I.4 Conclusion:

Now we can begin the design of the elements in the next chapter, since the majority of calculation principles have been defined, and the material base.

Chapter



Chapter II

Pre-dimensioning of the elements:

II.1. Introduction:

The advance dimension includes a combination of engineering expertise, mathematical calculations and a deep understanding of the intended use of the building and environmental context. Its primary objective is to determine the dimensions of various key structure elements such as columns, beams, panels and foundations. These initial dimensions serve as a starting point for further revised analysis and replication of design, allowing engineers and architects to assess the feasibility and performance of the structure.

The dimensions are selected in accordance with the recommendations contained in the RPA99 version 2003, CBA93, BAEL91.

The results obtained are not definitive, they can be increased after verification and the economy is taken in to consideration to avoid surplus steel and concrete.

II.2. Pre-sizing of elements:

II.2.1 The floors:

➤ Floor hollow body:

Hollow floor bodies are essential components in the design and construction of modern multi-storey buildings. Its light nature, physical efficiency, thermal and acoustic benefits, flexibility in service installation, speed of construction and fire resistance make it indispensable for sustainable, practical and cost-effective structures. It has a very important role in the structure of supporting vertical loads and then transferring them to bearing elements. It also acts as a firewall in the event of a fire.

In our project we have a hollow body floor and solid slab in the balconies.

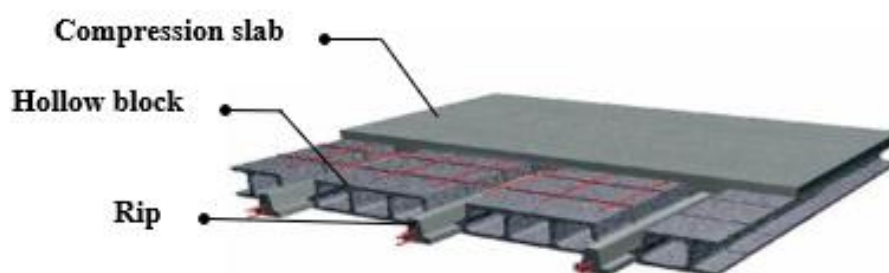

Figure II.1 Floor hollow block

The thickness of this floor is determined from the deflection condition:

According to the **CBA93 (art B.6.8.4.2.4)**: $h_t \geq \frac{L_{max}}{22.5}$

h_t : the height of the floor.

L_{max} : the greatest span of the joists (measured between bare).

In our building block, $L_{max} = 500 - 40 = 460$ cm

$h_t \geq \frac{460}{22.5} = 20.44$ cm, so $h_t = (20 + 5)$ cm

With:

- The height of hollow body: 20cm
- And the height of compressing slab is: 5 cm



Figure II.2 Cross section of hollow body floor

II.2.1.1 Rib width:

The cross section of the ribs is assimilated to a (T) section with the following geometric characteristic:

The width of compression table is equal to:

$$b = b_0 + 2b_1$$

With:

$$\frac{h_t}{3} \leq b_0 \leq \frac{h_t}{2} \rightarrow h_t = 25 \text{ cm}$$

$$\frac{25}{3} \leq b_0 \leq \frac{25}{2} \rightarrow 8.33 \text{ cm} \leq b_0 \leq 12.5 \text{ cm}$$

We adopt: $b_0 = 10$ cm.

$$b_1 = \min \left(\frac{L}{10}; \frac{L_0}{2} \right)$$

• L : maximum span of the rib.

• L_0 : Distance between bare ribs (the slab available on the market has $L_0 = 55$ cm)

$$L_0 = 65 - 10 = 55 \text{ cm}$$

$$b_1 = \min \left(\frac{460}{10}; \frac{55}{2} \right) = \min (46 \text{ cm}; 27.5 \text{ cm}), \text{ So: } b_1 = 27.5 \text{ cm}$$

With that:

$$b = b_0 + 2b_1 = 10+55$$

So:

$$b = 65 \text{ cm.}$$

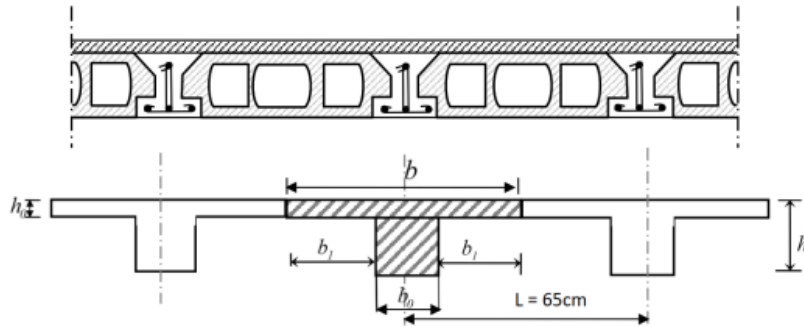
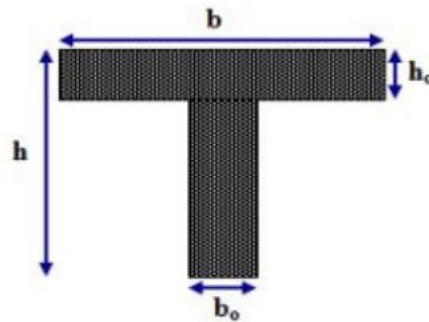

Figure II.3 The cross section of the rib

So, we take:

$$\begin{cases} h = 20 \text{ cm} \\ b_0 = 10 \text{ cm} \\ b = 65 \text{ cm} \end{cases}$$



➤ **Solid slab:**

A solid slab, in the context of construction and architecture, refers to a type of floor system that is made of solid concrete without any voids. It is a monolithic, continuous piece of concrete that spans between supports such as beams, columns, or walls. Solid slabs are used in buildings and other structures to provide a level surface for occupants and to transfer loads (such as from furniture, equipment, or people) to the supporting elements beneath

They are totally reinforced concrete floors poured on the spot, they are thin plates whose thickness is small in relation to the other dimensions, resting on 2,3 or 4 supports, consisting of beams, girders or walls, thus constituting floors or roofs.

The thickness of the slabs depends more often on the conditions of use than on the strength checks, so the thickness of the slabs will be deduced from the following conditions:

1-Fire resistance

e= 7 cm for an hour of firewalls.

e = 11 cm for two hours of firewalls

We take, e= 11 cm

2-Sound insulation

According to the (CBA93):

The floor thickness must be in the range

$$L/50 \leq e \leq L/40$$

$$\rightarrow 500/50 \leq e \leq 500/40$$

$$10\text{cm} \leq e \leq 12.5\text{cm}$$

To obtain good sound insulation

We limit our thickness: $e = 15\text{ cm}$

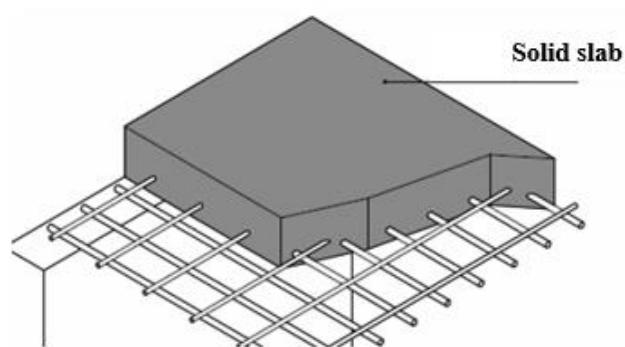

Figure II.4 Solid slab

II.2.2 Beams:

The beams will be pre-dimensioned according to the empirical formulas given by the CBA93 and checked afterwards according to the RPA99 V 2003.

The dimensions of the beams must respect **article 7.5.1 of the RPA 99 V 2003**:

- $h \geq 30\text{ cm}$
- $b \geq 20\text{ cm}$
- $\frac{h}{b} \leq 4$

According to CBA 93 rules we have

$$\frac{L_{max}}{15} \leq h \leq \frac{L_{max}}{10}$$

With:

- L: distance between post axis (larger range)
- h: beam height

$$0.3h \leq b \leq 0.7h$$

We have two types of beams:

II.2.2.1 Main beams:

- Receive the loads transmitted by the beams and distribute them to the columns on which these beams rest.
- Connect the posts.
- Support the slab.

In our case we have L= 5 m

$$\frac{460}{15} \leq h \leq \frac{460}{10}$$

$$30.66 \text{ cm} \leq h \leq 46 \text{ cm}$$

We take **h = 35 cm**

Now: $0.3 \times 35 \leq b \leq 0.7 \times 35$

$$10.50 \leq b \leq 24.5$$

We take **b = 30 cm**

Verification:

- $h = 35 \geq 30 \text{ cm} \dots\dots\dots \text{C. V}$
- $b = 30 \geq 20 \text{ cm} \dots\dots\dots \text{C. V}$
- $\frac{h}{b} = 1.667 \leq 4 \dots\dots\dots \text{C. V}$

II.2.2.2 Secondary beams:

Connect the gantries together so as not tip over.

L = 4.9 m

$$\frac{450}{15} \leq h \leq \frac{450}{10}$$

$$30 \text{ cm} \leq h \leq 45 \text{ cm}$$

We take **h = 35 cm**

$$0.3 \times 35 \leq b \leq 0.7 \times 35$$

$$10.05 \leq b \leq 24.5$$

We take **b = 30 cm**

Verification:

- $h = 35 \geq 30 \text{ cm} \dots\dots\dots \text{CV}$
- $b = 30 \geq 20 \text{ cm} \dots\dots\dots \text{CV}$

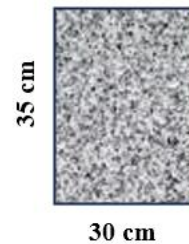

Figure II.5 Cross section of the main beam



Figure II.6 Cross section of the secondary beam

- $\frac{h}{b} = 1.167 \leq 4$ CV

II.2.3 The Columns:

The pre-dimensioning is calculated in accordance with the **BAEL91** and **RPA 99 V 2003** rules.

- $\min (b, h) \geq 25$ cm in Zone I and Zone IIa.
- $\min (b, h) \geq \frac{h_e}{20}$
- $0.25 \leq \frac{b}{h} \leq 4$

Our pre-sizing will apply to the column that supports more loads distributed over a surface.

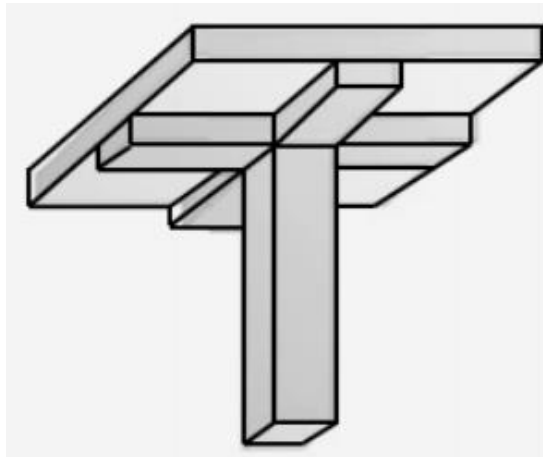

Figure II.7 Representation of the column most used

II.2.4 Shear wall: (RPA99/ V2003 A 7.7.1)

Shear walls are armed concrete support elements and a structural component of a building designed to resist side loads such as wind and earthquake forces. It is a vertical element that provides resistance to horizontal forces operating in parallel to the wall level. Shearing walls are essential in buildings to enhance their stability and reduce the risk of structural failure during earthquakes, high winds or other side loads.

The thickness shall be determined by reference to the floor clearance height and the condition stiffness of the ends.

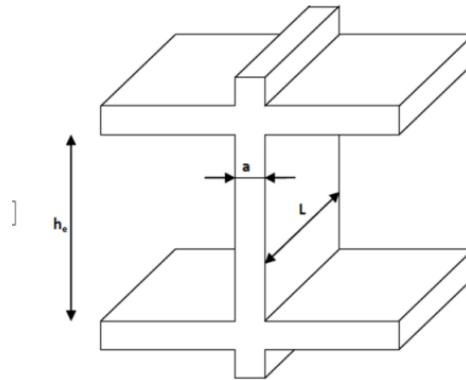

Figure II.8 Shear wall

According to **RPA 2003 article (7.7.1)** the minimum thickness «e» is **15 cm**.

It must check the following conditions:

$$\left\{ \begin{array}{l} e \geq \frac{h_e}{20} \text{ for the open sails.} \\ e \geq 15 \text{ cm} \\ L \geq 4e \end{array} \right.$$

h_e : floor clearance height.

e: thickness of sail.

$$h_e = h - \min(h_{pp}, h_{ps})$$

$$h_e = 306 - 35 = 271 \text{ cm}$$

$$\text{So: } e \geq \max(h_e/20; 15\text{cm})$$

$$e \geq \max(271/20 = 13.55; 15\text{cm}) \rightarrow e = 15 \text{ cm}$$

$$L \geq 4 \times e = 60 \text{ cm}$$

We take : **L = 60 cm**

II.2.5 Stairs:

In our building, the movement between the floors is through the stairs and the elevator.

Stairs are a series of steps or flights that are designed to provide a means of vertical movement between different levels of a building or structure. They consist of a sequence of flat, horizontal surfaces (steps) that are elevated at a consistent height from one another, allowing individuals to ascend or descend from one level to another with ease.

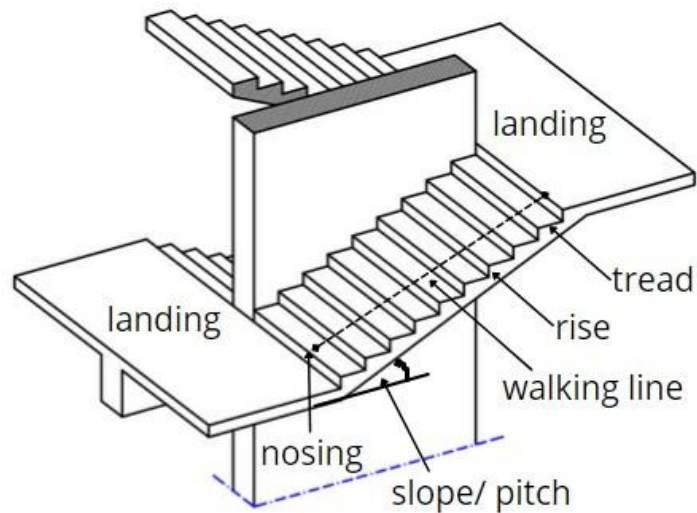

Figure II.9 The components of two-flight staircase

To size steps and counter steps, we generally use the formula of Blondel:

$$59 \text{ cm} \leq 2h+g \leq 66 \text{ cm}$$

h: Height of counter step $14 \text{ cm} \leq h \leq 20 \text{ cm}$

g: Step tread with $22 \text{ cm} \leq g \leq 33 \text{ cm}$

We take: $\begin{cases} h = 17 \text{ cm} \\ g = 30 \text{ cm} \end{cases}$

With that:

$$59 \text{ cm} \leq 2h+g = 64 \text{ cm} \leq 66 \text{ cm} \rightarrow \text{C.V}$$

- **Determination of number of steps:**

h_e : Floor height = 306 cm.

h : Height of counter step.

n : Number of risers.

$$n = \frac{h_e}{h} = \frac{306}{17} = 9$$

N: number of steps in a flight.

$$N = n - 1 = 9 - 1 = 8$$

- **Inclination of the bench:**

$$H = n \times h = 9 \times 17 = 153 \text{ cm}$$

$$\text{Climbing height: } H_1 = H_2 = 153 \text{ cm}$$

$$L_1 = g(n - 1) \Rightarrow L_1 = 30 \times (9 - 1) = 240 \text{ cm}$$

$$\tan(\alpha) = \frac{H}{L_1} = \frac{153}{240} = 0.6375$$

$$\alpha = \arctan(0,6375) = 32.52^\circ$$

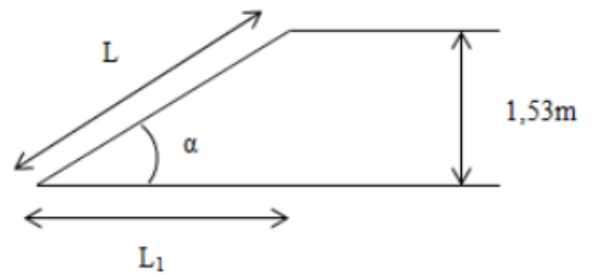

Figure II.10 Schema of bench

- **Bench span:**

$$L = \frac{H}{\sin(\alpha)} = \frac{1.53}{\sin(32.52)} = 2.85 \text{ m}$$

Or:

$$L = \sqrt{(H)^2 + (L_1)^2}$$

$$L = \sqrt{(1.53)^2 + (2.4)^2} = 2.85 \text{ m}$$

- **Bench thickness:**

-

$$\frac{L}{30} = \frac{285}{30} \leq e \leq \frac{L}{20} = \frac{285}{20}$$

$$14.25 \text{ cm} \leq e \leq 14.25 \text{ cm}$$

→ We take **e = 14 cm.**

II.2.5.1 Study of landing beam : (According BAEL91)

$$L = 2.70 - 0.40 = 2.3 \text{ m}$$

$$\frac{L}{15} \leq h \leq \frac{L}{10}$$

$$15.33 \text{ cm} \leq h \leq 23 \text{ cm}$$

We take **h = 40 cm**

$$\text{Now: } 0.3 \times 35 \leq b \leq 0.7 \times 35$$

$$10.5 \leq b \leq 24.5$$

We take **b = 40 cm**

We adopt a rectangular section **(b×h) = (40×40) cm²**

Verification:

- $h = 40\text{cm} \geq 30\text{ cm} \dots\dots\dots \text{CV}$
- $b = 40\text{ cm} \geq 20\text{ cm} \dots\dots\dots \text{CV}$
- $\frac{h}{b} = 1 \leq 4 \dots\dots\dots \text{CV}$

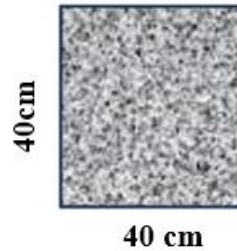

Figure II.11 Cross section of the landing beam bench

II.2.6 Parapet wall :

Parapet wall is an armed concrete element located on the edge of a roof, balcony, bridge or similar structure. It is usually constructed above the roof line or on the edge of the structure to prevent people from falling and to prevent the infiltration of rainwater between the slope and the terrace floor. Parapet walls can serve functional and aesthetic purposes, providing security while enhancing the building's architectural design. It can vary in height and design based on the specific requirements of the structure and the applicable building laws.

Is subjected to its own weight (G) which gives a normal N_G force and an unweighted operating load estimated at 1KN/ml causing a bending moment as well as a FP seismic force.

✓ Calculation assumptions:

- The calculation will be done for a 1 ml strip.
- Cracking is considered harmful.
- The parapet wall will be calculated in compound bending

The surface of parapet wall:

$$S = (0,12 \times 0,6) + (0,18 \times 0,05) + \left(\frac{0,18+0,12}{2}\right)$$

$$S = 0,09 \text{ m}^2$$

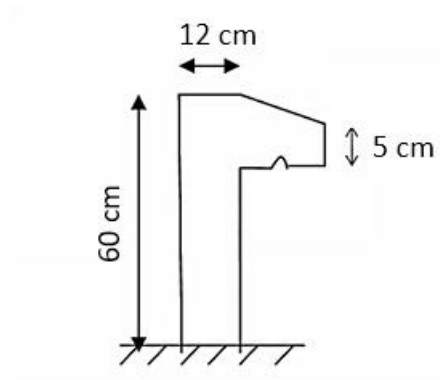

Figure II.12 Parapet wall schema

Chapter

III

Chapter III

Evaluation of the loads:

III.1 Load assessment:

The assessment of the loads is overload consists of calculating successively for each supporting element of the structure, the load that returns to it at each floor and this until the foundation.

Regulatory expenses are permanent expenses (G) and operating expenses (Q).

III.1.1 Load assessment for inaccessible Terrace:

- **Floor hollow block:**

Table III.1 Load assessment for inaccessible Terrace (Floor hollow block)

Materials	Thickness(m)	Volume weight (KN/ m ³)	Weight (KN/m ²)
Gravel protection	0.04	17	0.68
Sealing	0.02	6	0.12
Slope shape	0.07	22	1.54
Thermal insulation	0.04	4	0.16
Hollow block slab	0.20+0.05	14	3.5
Plaster	0.02	14	0.28
Permanent load G			6.28

Operating load Q=1 KN/m²

- **Solid slab floor:**

Table III.2 Load assessment for inaccessible Terrace (Solid slab floor)

Materials	Thickness(m)	Volume weight (KN/ m ³)	Weight (KN/m ²)
Gravel protection	0.04	20	0.8
Sealing	0.02	6	0.12
Slope shape	0.01	22	2.20
Solid slab	0.15	25	3.75
Thermal insulation	0.04	0.25	0.01
Cement rendering	0.015	18	0.27
Permanente load G			7.15

Operating load Q=1 KN/m²

III.1.2 Assessment of the load of common Floor:

- Floor hollow block:

Table III.3 Assessment of the load of common Floor (Floor hollow block)

Materials	Thickness(m)	Volume weight (KN/ m ³)	Weight(KN/m ²)
Tiles	0.02	22	0.44
Bending mortar	0.03	20	0.6
Bed sand	0.02	17	0.34
Hollow block slab	0.20+0.05	14	3.5
Plaster	0.02	14	0.2
Partition walls	0.1	7.5	0.75
Permanent load G			5.83

Operating load Q=1.5 KN/m²

- Solid slab floor:

Table III.4 Assessment of the load of common Floor (Solid slab floor)

Materials	Thickness(m)	Volume weight (KN/ m ³)	Weight (KN/m ²)
Tiles	0.02	20	0.4
Bending mortar	0.02	20	0.4
Bed sand	0.02	18	0.36
Solid slab	0.15	/	3.75
Cement rendering	0.015	18	0.27
Guard rail	/	/	1
Permanente load G			6.18

Operating load Q=1.5 KN/m²

III.1.3 Assessment of the loads of Masonry:• **External wall:***Table III.5 Assessment of the loads of Masonry (External wall)*

Materials	Thickness(m)	Volume weight (KN/ m ³)	Weight (KN/m ²)
Cement rendering	0.02	20	0.4
Hollow block	0.25	9	2.25
Plaster	0.02	14	0.28
Permanent load G			2.93

• **Interior wall:***Table III.6 Assessment of the loads of Masonry (Interior wall)*

Materials	Thickness(m)	Volume weight (KN/ m ³)	Weight (KN/m ²)
Cement rendering	0.02	20	0.4
Hollow block	0.10	9	0.9
Plaster	0.02	14	0.28
Permanent load G			1.58

III.1.4 Load assessment for balconies:• **Balcony terrace:**

The balconies are full slab.

Table III.7 Assessment of the loads of balconies

Materials	Thickness(m)	Volume weight (KN/ m ³)	Weight (KN/m ²)
Tiles	0.02	20	0.4
Bending mortar	0.02	20	0.4
Bed sand	0.02	18	0.36
Solid slab	0.15	25	3.75
Cement rendering	0.02	18	0.36
Permanent load G			5.27

Operating load Q=3.5 KN/m²

- **Concentrated load (guardrail load)**

Table III.8 Assessment of the loads of balconies (guardrail load)

Materials	Surface	Volume weight (KN/m ³)	Weight (KN/m ²)
Plaster	0.02	14	0.28
Masonry	0.10	9	0.90
Cement rendering	0.02	18	0.36
Permanent load G			1.54

III.1.5 Load assessment for the staircase:

- **Landing**

Table III.9 Load assessment for the staircase (Landing)

Materials	Thickness(m)	Volume weight (KN/ m ³)	Weight (KN/m ²)
Tiles	0.02	22	0.44
Bending mortar	0.02	20	0.4
Band sand	0.02	18	0.36
Solid slab	0.15	25	3.5
Cement plaster	0.02	18	0.36
Permanent load G			5.31

Operating load $Q=2.5 \text{ KN/m}^2$

- **Bench (e= 14 cm)**

Table III.10 Load assessment for the staircase (Bench)

Materials	Thickness(m)	Volume weight (KN/ m ³)	Weight (KN/m ²)
Tiles	0.02	22	0.44
Bending mortar	0.02	20	0.4
Steps	0.17	11	1.87
Bench	0.14	$25/\cos\alpha$	4.44
Plaster	0.02	20	0.4
Guard rail	/	/	0.6
Permanent load G			8.15

Operating load $Q=2.5 \text{ KN/m}^2$

III.1.6 Assessment loads for parapet wall:

$$S=0.09 \text{ m}^2$$

$$P = \left(\frac{0.12+0.6}{2} + \frac{0.18+0.05}{2} + (0.17 + 0.12 + 0.12) \right) = 0.885 \text{ m}$$

P: circumference.

Table III.11 Assessment loads for parapet wall

Materials	Surface	Volume weight (KN/m ³)	Weight (KN/m ²)
parapet wall	0.09	25	2.25
Rendering	0.018	20	0.36
Permanent load G			2.61

Operating load Q = 1 KN/m²

III.2 Lowering loads:

In order to ensure the strength and stability of the structure, a distribution of loads and overloads for each element is necessary. The descent of the loads allows the evaluation of most of the loads returning to each element of the structure.

The descent of load is done from the highest level (framework or roof terrace) to the lower level and this to the lowest level (the foundations).

In order to calculate operational loads, we use the law of digression, and for permanent loads the surface area of the most stressed columns must be calculated.

As it is rare for all the operating loads to act simultaneously, the law of degression is applied for their determination, which consists in reducing the identical loads on each floor from 10% to 0.5%.

Which give:

- In the terrace Q_0
- Under the first floor from the top ($i = 1$) $Q_0 + Q_1$
- Under the second floor ($i = 2$): $Q_0 + 0.95 \times (Q_1 + Q_2)$
- Under the third floor ($i = 3$): $Q_0 + 0.90 \times (Q_1 + Q_2 + Q_3)$
- Under the fourth floor ($i = 4$): $Q_0 + 0.90 \times (Q_1 + Q_2 + Q_3 + Q_4)$
- For n floor ($n \geq 5$): $Q_0 + \frac{3+n}{2n} \times (Q_1 + Q_2 + Q_2 + Q_3 + \dots + Q_n)$

III.2.1 Operating loads:*Table III.12 Degression operating loads by level*

Story	Degression loads by level	Operating Load KN/m ²
6	1	1
5	1+1.5	2.5
4	1+0.95×1.5×2	3.85
3	1+0.9×1.5×3	5.05
2	1+0.85×1.5×4	6.1
1	1+0.8×1.5×5	7
GF	1+0.75×1.5×6	7.75

III.2.2 Application example of the loads descent:

For our project, the law of degression of charge is applied as follow:

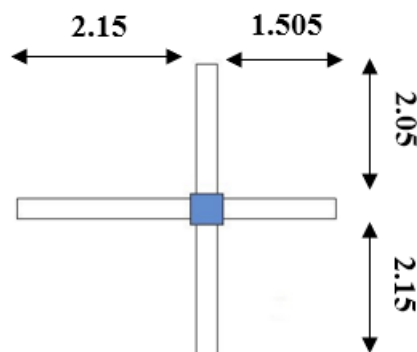
III.2.2.1 Central column:*Figure III.1 Central column*

$$S_{Total} = (2.15 + 1.505 + 0.40) \times (2.05 + 2.15 + 0.40)$$

$$S_{Total} = 18.653 \text{ m}^2$$

$$S_{Floor} = S_{Total} - S_{Column} - S_{beam}$$

$$S_{Floor} = (2.15 \times 2.05) + (1.505 \times 2.05) + (1.505 \times 2.15) + (2.15 \times 2.15)$$

$$S_{Floor} = 15.35 \text{ m}^2$$

Length of main beam:

$$L_{mb} = 4.2 \text{ m}$$

Length of secondary beam:

$$L_{sb} = 3.65 \text{ m}$$

Table III.13 Results of lowering loads from the central column

Story	Element	G (KN)	Q (KN)
N1-1	The terrace floor is inaccessible: 15.35×6.28 Main beam: $0.3 \times 0.35 \times 4.2 \times 25$ Secondary beam : $0.3 \times 0.35 \times 3.65 \times 25$ Overload: $Q_0 = 1 \times 15.35$	96.39 11.02 9.58	15.35
	Total	116.99	15.35
N2-2	From N1-1 The current floor: 15.35×5.83 Main beam: $0.3 \times 0.35 \times 4.2 \times 25$ Secondary beam : $0.3 \times 0.35 \times 3.65 \times 25$ Column: $0.4 \times 0.4 \times 3.06 \times 25$ Overload: $Q_1 = 1.5 \times 15.35 = 23.02$ $Q_0 + Q_1$	116.99 89.49 11.02 9.58 12.24	38.37
	Total	239.32	38.37
N3-3	From N2-2 The current floor: 15.35×5.83 Main beam: $0.3 \times 0.35 \times 4.2 \times 25$ Secondary beam : $0.3 \times 0.35 \times 3.65 \times 25$ Column: $0.40 \times 0.40 \times 3.06 \times 25$ Overload: $Q_2 = 1.5 \times 15.35 = 23.02$ $Q_0 + 0.95(Q_1 + Q_2)$	239.12 89.49 11.02 9.58 12.24	59.08
	Total	361.45	59.08
N4-4	From N3-3 The current floor: 15.35×5.83 Main beam: $0.3 \times 0.35 \times 4.2 \times 25$ Secondary beam : $0.3 \times 0.35 \times 3.65 \times 25$ Column: $0.40 \times 0.40 \times 3.06 \times 25$ Overload: $Q_3 = 1.5 \times 15.35 = 23.02$ $Q_0 + 0.9(Q_1 + Q_2 + Q_3)$	361.45 89.49 11.02 9.58 12.24	77.50
	Total	483.78	77.50

N5-5	From N4-4 The current floor: 15.35×5.83 Main beam: $0.3 \times 0.35 \times 4.2 \times 25$ Secondary beam : $0.3 \times 0.35 \times 3.65 \times 25$ Column: $0.40 \times 0.40 \times 3.06 \times 25$ Overload: $Q_4 = 1.5 \times 15.35 = 23.02$ $Q_0 + 0.85(Q_1 + Q_2 + Q_3 + Q_4)$	483.78 89.49 11.02 9.58 12.24	93.618
	Total	606.11	93.618
N6-6	From N5-5 The current floor: 15.35×5.83 Main beam: $0.3 \times 0.35 \times 4.2 \times 25$ Secondary beam : $0.3 \times 0.35 \times 3.65 \times 25$ Column: $0.40 \times 0.40 \times 3.06 \times 25$ Overload: $Q_5 = 1.5 \times 15.35 = 23.02$ $Q_0 + 0.80 \times (Q_1 + Q_2 + Q_3 + Q_4 + Q_5)$	606.11 89.49 11.02 9.58 12.24	107.43
	Total	728.44	107.43
N7-7	From N6-6 The current floor: 15.35×5.83 Main beam: $0.3 \times 0.35 \times 4.2 \times 25$ Secondary beam : $0.3 \times 0.35 \times 3.65 \times 25$ Column: $0.40 \times 0.40 \times 3.06 \times 25$ Overload: $Q_6 = 1.5 \times 15.35 = 23.02$ $Q_0 + 0.75(Q_1 + Q_2 + Q_3 + Q_4 + Q_5 + Q_6)$	728.44 89.49 11.02 9.58 12.24	118.94
	Total	850.77	118.94
NGF	From N7-7 The current floor: 15.35×5.83 Main beam: $0.3 \times 0.35 \times 4.2 \times 25$ Secondary beam : $0.3 \times 0.35 \times 3.65 \times 25$ Column: $0.40 \times 0.40 \times 3.06 \times 25$ Overload: $Q_{GF} = 1.5 \times 15.35 = 23.02$ $Q_0 + 0.71(Q_1 + Q_2 + Q_3 + Q_4 + Q_5 + Q_6 + Q_{GF})$	850.77 89.49 11.02 9.58 12.24	129.76
	Total	973.1	129.76

For the central column:

G= 973.1 KN

Q=129.76 KN

III.2.2.2 Corner column:

$$S_{Floor} = 1.3 \times 2$$

$$S_{Floor} = 2.6 \text{ m}^2$$

Length of main beam:

$$L_{mb} = 1.3 \text{ m}$$

Length of secondary beam:

$$L_{sb} = 2 \text{ m}$$

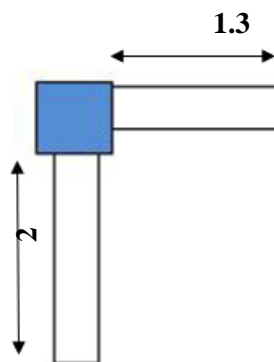

Figure III.2 Corner column

III.2.2.3 Edge column:

Figure III.3 Edge column

$$S_{Total} = (1.3 + 1.3 + 0.40) \times (2.1 + 0.40)$$

$$S_{Total} = 7.5 \text{ m}^2$$

$$S_{Floor} = (1.3 \times 2.1) \times 2$$

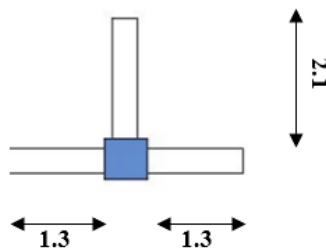
$$S_{Floor} = 5.46 \text{ m}^2$$

Length of main beam:

$$L_{mb} = 2.1 \text{ m}$$

Length of secondary beam:

$$L_{sb} = 2.6 \text{ m}$$

Table III.14 Results of lowering loads from the Corner column

Story	Element	G (KN)	Q (KN)
N1-1	parapet wall: $G = 4.1 \times 2.61$ The terrace floor is inaccessible: 2.6×6.28 Main beam: $0.3 \times 0.35 \times 2 \times 25$ Secondary beam : $0.3 \times 0.35 \times 1.3 \times 25$ Overload: $Q_0 = 1 \times 2.6$	10.7 16.33 5.25 3.41	2.6
	Total	35.69	2.6
N2-2	From N1-1 The current floor: 2.6×5.83 Main beam: $0.3 \times 0.35 \times 2 \times 25$ Secondary beam : $0.3 \times 0.35 \times 1.3 \times 25$ Column: $0.40 \times 0.40 \times 3.06 \times 25$ Overload: $Q_1 = 1.5 \times 2.6 = 3.9$ $Q_0 + Q_1$	35.69 15.16 5.25 3.41 12.24	6.5
	Total	71.75	6.5
N3-3	From N2-2 The current floor: 2.6×5.83 Main beam: $0.3 \times 0.35 \times 2 \times 25$ Secondary beam : $0.3 \times 0.35 \times 1.3 \times 25$ Column: $0.40 \times 0.40 \times 3.06 \times 25$ Overload: $Q_2 = 1.5 \times 2.6 = 3.9$ $Q_0 + 0.95(Q_1 + Q_2)$	71.75 15.16 5.25 3.41 12.24	10.01
	Total	107.81	10.01
N4-4	From N3-3 The current floor: 2.6×5.83 Main beam: $0.3 \times 0.35 \times 2 \times 25$ Secondary beam : $0.3 \times 0.35 \times 1.3 \times 25$ Column: $0.40 \times 0.40 \times 3.06 \times 25$ Overload: $Q_3 = 1.5 \times 2.6 = 3.9$ $Q_0 + 0.9(Q_1 + Q_2 + Q_3)$	107.81 15.16 5.25 3.41 12.24	13.13
	Total	143.87	13.13

N5-5	From N4-4 The current floor: 2.6×5.83 Main beam: $0.3 \times 0.35 \times 2 \times 25$ Secondary beam : $0.3 \times 0.35 \times 1.3 \times 25$ Column: $0.40 \times 0.40 \times 3.06 \times 25$ Overload: $Q_4 = 1.5 \times 2.6 = 3.9$ $Q_0 + 0.85(Q_1 + Q_2 + Q_3 + Q_4)$	143.87 15.16 5.25 3.41 12.24	15.86
	Total	179.98	15.86
N6-6	From N5-5 The current floor: 2.6×5.83 Main beam: $0.3 \times 0.35 \times 2 \times 25$ Secondary beam : $0.3 \times 0.35 \times 1.3 \times 25$ Column: $0.40 \times 0.40 \times 3.06 \times 25$ Overload: $Q_5 = 1.5 \times 2.6 = 3.9$ $Q_0 + 0.80 \times (Q_1 + Q_2 + Q_3 + Q_4 + Q_5)$	179.98 15.16 5.25 3.41 12.24	18.2
	Total	216.04	18.2
N7-7	From N6-6 The current floor: 2.6×5.83 Main beam: $0.3 \times 0.35 \times 2 \times 25$ Secondary beam : $0.3 \times 0.35 \times 1.3 \times 25$ Column: $0.40 \times 0.40 \times 3.06 \times 25$ Overload: $Q_6 = 1.5 \times 2.6 = 3.9$ $Q_0 + 0.75(Q_1 + Q_2 + Q_3 + Q_4 + Q_5 + Q_6)$	216.04 15.16 5.25 3.41 12.24	20.15
	Total	252.1	20.15
NGF	From N7-7 The current floor: 2.6×5.83 Main beam: $0.3 \times 0.35 \times 2 \times 25$ Secondary beam : $0.3 \times 0.35 \times 1.3 \times 25$ Column: $0.40 \times 0.40 \times 3.06 \times 25$ Overload: $Q_{GF} = 1.5 \times 2.6 = 3.9$ $Q_0 + 0.71(Q_1 + Q_2 + Q_3 + Q_4 + Q_5 + Q_6 + Q_{GF})$	252.1 15.16 5.25 3.41 12.24	21.98
	Total	288.16	21.98

For the Corner column:

G = 288.16 KN

Q = 21.98 KN

Table III.15 Results of lowering loads from the Edge column

Story	Element	G (KN)	Q (KN)
N1-1	parapet wall: $G = 3 \times 2.61$ The terrace floor is inaccessible: 5.46×6.28 Main beam: $0.3 \times 0.35 \times 2.1 \times 25$ Secondary beam : $0.3 \times 0.35 \times 2.6 \times 25$ Overload: $Q_0 = 1 \times 5.46$	7.83 34.30 5.51 6.82	5.46
	Total	54.46	5.46
N2-2	From N1-1 The current floor: 5.46×5.83 Main beam: $0.3 \times 0.35 \times 2.1 \times 25$ Secondary beam : $0.3 \times 0.35 \times 2.6 \times 25$ Column: $0.40 \times 0.40 \times 3.06 \times 25$ Overload: $Q_1 = 1.5 \times 5.46 = 8.19$ $Q_0 + Q_1$	54.46 31.84 5.51 6.82 12.24	13.65
	Total	110.87	13.65
N3-3	From N2-2 The current floor: 5.46×5.83 Main beam: $0.3 \times 0.35 \times 2.1 \times 25$ Secondary beam : $0.3 \times 0.35 \times 2.6 \times 25$ Column: $0.40 \times 0.40 \times 3.06 \times 25$ Overload: $Q_2 = 1.5 \times 5.46 = 8.19$ $Q_0 + 0.95(Q_1 + Q_2)$	110.87 31.84 5.51 6.82 12.24	21.02
	Total	167.28	21.02
N4-4	From N3-3 The current floor: 5.46×5.83 Main beam: $0.3 \times 0.35 \times 2.1 \times 25$ Secondary beam : $0.3 \times 0.35 \times 2.6 \times 25$ Column: $0.40 \times 0.40 \times 3.06 \times 25$ Overload: $Q_3 = 1.5 \times 5.46 = 8.19$ $Q_0 + 0.9(Q_1 + Q_2 + Q_3)$	167.28 31.84 5.51 6.82 12.24	27.60
	Total	223.70	27.60

N5-5	From N4-4 The current floor: 5.46×5.83 Main beam: $0.3 \times 0.35 \times 2.1 \times 25$ Secondary beam : $0.3 \times 0.35 \times 2.6 \times 25$ Column: $0.40 \times 0.40 \times 3.06 \times 25$ Overload: $Q_4 = 1.5 \times 5.46 = 8.19$ $Q_0 + 0.85(Q_1 + Q_2 + Q_3 + Q_4)$	223.70 31.84 5.51 6.82 12.24	33.30
	Total	280.11	33.30
N6-6	From N5-5 The current floor: 5.46×5.83 Main beam: $0.3 \times 0.35 \times 2.1 \times 25$ Secondary beam : $0.3 \times 0.35 \times 2.6 \times 25$ Column: $0.40 \times 0.40 \times 3.06 \times 25$ Overload: $Q_5 = 1.5 \times 5.46 = 8.19$ $Q_0 + 0.80 \times (Q_1 + Q_2 + Q_3 + Q_4 + Q_5)$	280.11 31.84 5.51 6.82 12.24	38.22
	Total	336.52	62.67
N7-7	From N6-6 The current floor: 5.46×5.83 Main beam: $0.3 \times 0.35 \times 2.1 \times 25$ Secondary beam : $0.3 \times 0.35 \times 2.6 \times 25$ Column: $0.40 \times 0.40 \times 3.06 \times 25$ Overload: $Q_6 = 1.5 \times 5.46 = 8.19$ $Q_0 + 0.75(Q_1 + Q_2 + Q_3 + Q_4 + Q_5 + Q_6)$	336.52 31.84 5.51 6.82 12.24	42.31
	Total	392.93	42.31
NGF	From N7-7 The current floor: 5.46×5.83 Main beam: $0.3 \times 0.35 \times 2.1 \times 25$ Secondary beam : $0.3 \times 0.35 \times 2.6 \times 25$ Column: $0.40 \times 0.40 \times 3.06 \times 25$ Overload: $Q_{GF} = 1.5 \times 5.46 = 8.19$ $Q_0 + 0.71(Q_1 + Q_2 + Q_3 + Q_4 + Q_5 + Q_6 + Q_{GF})$	392.93 31.84 5.51 6.82 12.24	
	Total	449.34	46.16

For the edge column

G=449.34 KN

Q=46.16 KN

III.2.3 Verification of column section (40×40) (CBA art7.4.1):**Central column:**

$$G= 973.1 \text{ KN} / Q=129.76 \text{ KN}$$

Where:

$$N_u = 1.35G + 1.5Q$$

$$N_u = 1.35 \times 973.1 + 1.5 \times 129.76$$

$$N_u = 1508.325 \text{ KN}$$

We increase 10%

$$\Rightarrow N_u = 1.1 \times 1508.325 = 1659.16 \text{ KN}$$

So:

$$N_u = 1659.16 \text{ KN}$$

Edge column:

$$G= 449.34 \text{ KN} / Q=46.16 \text{ KN}$$

Where:

$$N_u = 1.35G + 1.5Q$$

$$N_u = 1.35 \times 449.34 + 1.5 \times 46.16$$

$$N_u = 675.85 \text{ KN}$$

We increase 10%

$$\Rightarrow N_u = 1.1 \times 675.85 = 743.43 \text{ KN}$$

So:

$$N_u = 743.43 \text{ KN}$$

Corner column:

$$G= 288.16 \text{ KN} / Q= 21.98 \text{ KN}$$

Where:

$$N_u = 1.35G + 1.5Q$$

$$N_u = 1.35 \times 288.16 + 1.5 \times 21.98$$

$$N_u = 421.99 \text{ KN}$$

We increase 10%

$$\Rightarrow N_u = 1.1 \times 421.99 = 464.19 \text{ KN}$$

So:

$$N_u = 464.19 \text{ KN}$$

According to the **CBA93 (Art B.8.4.1)** the ultimate acting normal force N_u of a column must be at most equal to the following value:

$$N_u \leq \overline{N_u} \Rightarrow N_u \leq \alpha \times \left(\frac{Br \times f_{c28}}{0.9 \times \gamma_b} + \frac{A_s \times f_{c28}}{\gamma_s} \right) \text{ With:}$$

α : Coefficient as a function of mechanical slenderness λ , who take values:

$$\left\{ \begin{array}{ll} \alpha = \frac{0.85}{1 + 0.2 \left(\frac{\lambda}{35} \right)^2} & \text{for } \lambda \leq 50 \\ \alpha = 0.60 \left(\frac{50}{\lambda} \right)^2 & \text{for } 50 < \lambda \leq 70 \end{array} \right.$$

With:

Br : Reduced section of the column obtained by deducting from its real section 1 cm thickness over its entire peripheral.

γ_b : safety factor, in general case $\gamma_b = 1.5$

f_{c28} : Compressive strength at 28 days $f_{c28} = 25$ MPa.

γ_s : safety coefficient of steel, in general case $\gamma_s = 1.15$

f_e : Yield strength of steel $f_e = 400$ MPa

$$Br = (a-2)(b-2) \Rightarrow Br = (40-2)(40-2) = 1444 \text{ cm}^2 = 0.1444 \text{ m}^2$$

$$l_f = 0.7 \times 3.06 = 2.142 \text{ m} = 214.20 \text{ cm}$$

$$\lambda = \frac{l_f}{i} \quad \text{and} \quad i = \sqrt{\frac{I}{A}}$$

$$I = \frac{b \times h^3}{12} = \frac{40 \times 40^3}{12} = 213333.33 \text{ cm}^4$$

$$\Rightarrow i = \sqrt{\frac{I}{A}} = \Rightarrow \sqrt{\frac{213333.33}{40 \times 40}} = 11.54 \text{ cm}$$

$$\Rightarrow \lambda = \frac{2.142}{11.54} = 18.56 \leq 50 \dots\dots\dots \text{C. V}$$

$$\alpha = \frac{0.85}{1+0.2\left(\frac{\lambda}{35}\right)^2} = \frac{0.85}{1+0.2\left(\frac{18.56}{35}\right)^2} = 0.804$$

A_s : Compressed steel section (RPA99 V2003)

Zone IIa $\Rightarrow 0.8\% Br$

$$A_s = \frac{0.8 \times Br}{100} = \frac{0.8 \times 1444}{100} = 11.55 \text{ cm}^2$$

$$\overline{N}_u \leq 0.804 \times \left(\frac{0.1444 \times 25}{0.9 \times 1.5} + \frac{11.55 \times 10^{-4} \times 25}{1.15} \right) = 2.17 \text{ MN} = 2170.14 \text{ KN} \Rightarrow \text{Verified condition}$$

We take $(b \times h) = (40 \times 40) \text{ cm}^2$.

Table III.16 Verification the section of all types column

Column	G (KN)	Q(KN)	Nu=1.35G+1.5Q(KN)	10%Nu(KN)	\overline{N}_u (KN)	Nu \leq \overline{N}_u
Central C	973.1	129.76	1508.325	1659.16	2813	C.V
Edge C	449.34	46.16	675.85	743.43	2813	C.V
Corner C	288.16	21.98	421.99	464.19	2813	C.V

Chapter

IV

Chapter IV

Study of secondary elements:

IV.1. Introduction :

In the study of multi-story buildings, understanding the design, integration, and performance of these secondary elements is crucial for achieving holistic solutions that meet the diverse needs of occupants, comply with regulatory requirements, and contribute to sustainable building practices.

Through meticulous analysis and innovative design approaches, architects, engineers, and construction professionals continually advance the study and implementation of secondary elements to create buildings that are not only structurally sound but also aesthetically pleasing, environmentally responsible, and conducive to human well-being.

Secondary elements in construction refer to components and features that support or complement the primary structural elements of a building. While primary elements such as columns, beams and slabs provide main structural support and stability. secondary elements achieve different functions related to aesthetics, comfort, safety and functionality. These (non-structural) elements play critical roles in improving overall performance, users' safety and the attractiveness of buildings.

In this section we discuss the calculation of the following non-structural (secondary elements):

- The parapet.
- Hollow body floors.
- The stairs and the landing beam.
- Machine slab.
- Balconies.

The calculation of secondary elements is typically conducted considering both permanent loads and live loads (or overloads) that structures may experience during their service life.

The calculation and design of secondary elements, are often performed according to specific regulations and standards. The BAEL 91 regulation, additionally adherence to the Algerian systemic regulation RPA99/2003 is essential. RPA99/2003 focuses on seismic design and detailing requirements to mitigate the effects of earthquakes on structures.

IV.2 Study of the parapet :

The parapet is an essential secondary element in building design, particularly in structures with elevated floors or roofs, it is made of reinforced concrete. It refers to a low protective wall or barrier located at the edge of a platform, terrace, balcony, or roof. It is calculated as a console restrained in the slab, stressed in compound bending.

IV.2.1 Calculation principal :

- The calculation will be made for a strip of 1 linear meter.
- Cracking is considered harmful.
- The parapet will be calculated in compound bending.

IV.2.2 Assessment of loads for the parapet :**IV.2.2.1 Calculation principal :** (RPA 99 V 2003 art 6.2.3)

As we found in the last chapter:

$$G = 2,61 \text{ KN/ml} \quad Q = 1 \text{ KN/ml}$$

The horizontal design force F_p acting on the non-structural elements are calculated according to the formula of the seismic force:

$$F_p = 4 A C_p W_p$$

With:

A: Zone acceleration coefficient obtained in (RPA99V2003 the table 4.1) for the appropriate zone and usage group.

C_p : Horizontal force factor varying between 0.3 and 0.8.

W_p : Weight of the considered elements.

Therefore:

$$A = 0.25 \text{ (usage 1A, zone II a).}$$

$$C_p = 0.8$$

$$W_p = 2.61 \text{ KN}$$

$$F_p = 4 \times 0.25 \times 0.8 \times 2.61 = 2.08 \text{ KN}$$

$$Q = 1 < F_p = 2.08$$

(So, the parapet to be stable vis-à-vis the seismic action, so it is necessary to use $Q = F_p = 2.08 \text{ KN}$)

The parapet is calculated in relation to the most unfavorable solicitations.

IV.2.2.2 Solicitations :

- Normal effort :

$$N_G = W_p = 2.61 \text{ KN/ml} \quad \rightarrow \quad N_Q = 0 \text{ KN/ml}$$

The gross-up coefficients are not taken into account because the parapet weight is a stabilizing weight « Favorable Effect G_{min} »

- Bending moment :

The moment of the permanent load is zero $\rightarrow M_G = 0 \text{ KN.m}$

- The moment of reversal due to horizontal force :

$$M_Q = F_p \times h = 2.08 \times 0.6 = 1.25 \text{ KN.m}$$

IV.2.3 Combination of loads :

• **U.L.S**

$$N_u = N_G + 1.5N_Q$$

$$\text{So: } N_u = (1 \times 2,61) + 0 \rightarrow N_u = 2.61 \text{ KN}$$

$$M_u = 1.35 M_G + 1,5 M_Q$$

$$\text{With } M_G = 0 \text{ and } M_Q = 1.25 \text{ KN.m}$$

$$M_u = 1,5 \times 1.25 \rightarrow M_u = 1.875 \text{ KN.m}$$

$$T_u = 1.5 Q = 1.5 \times 1.875 = 2.81 \text{ KN}$$

- **S.L.S:**

$$N_s = N_G + N_Q = W_p$$

$$\text{So: } N_s = 2.61 \text{ KN}$$

$$M_s = M_G + M_Q \quad \text{With: } M_G = 0$$

$$\text{So: } M_s = 0 + 1.25$$

$$M_s = 1.25 \text{ KN.m}$$

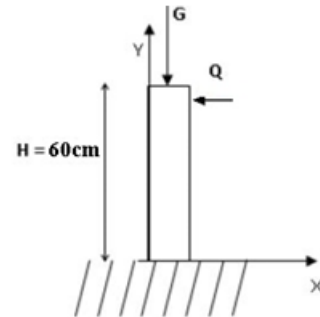

Figure IV.1 Action on the parapet

IV.2.4 Reinforcement calculation :

IV.2.4.1 Eccentricity calculation :

Eccentricity is determined by evaluating the distance between the center of gravity of the cross-section of the element and the action line of the applied load. This distance is often expressed in terms of moments, which are calculated by multiplying the eccentricity by the applied force.

According to the (CBA93 art A.4.3.5).

The sections subjected to a normal compressive force must be justified with respect to the ultimate state of shape stability by replacing the real eccentricity: $e_1 = \frac{M_u}{N_u}$ (in compound bending) by a total eccentricity calculated:

$$e = e_1 + e_a + e_2$$

with:

e_1 : eccentricity (so-called first order), of the resultant of the normal stresses, before application of the additional eccentricity.

e_2 : eccentricity due to second order effects, related to the deformation of the structure.

e_a : additional eccentricity translating the initial geometrical imperfections (after execution).

➤ **U.L.S:**

$$e_1 = \frac{M_u}{N_u} = \frac{1.875}{2.61} = 0.71 \text{ m}$$

$$e_a = \max\left(\frac{L}{250}; 2 \text{ cm}\right) = \max\left(\frac{60}{250} = 0.24 \text{ cm}; 2 \text{ cm}\right)$$

L: real length of the parapet.

$$e_a = 2\text{cm}$$

$$e_2 = \frac{3 \times l_f^2}{10^4 \times h} (2 + \alpha \emptyset)$$

With:

L_f : buckling length of the parapet.

$h = 10$ cm: Total height of the section in the direction of buckling.

α : the ratio of the first order moment, due to the permanent and quasi-permanent loads, at the total first-order moment, these moments being taken before application of the coefficients:

$$\alpha = 10 \times \left[1 - \frac{M_u}{1.5M_s} \right] = 10 \times \left[1 - \frac{1.875}{1.5 \times 1.25} \right] = 0$$

\emptyset : is the ratio of the final deformation due to creep to the instantaneous deformation under the load considered; this ratio is generally taken equal to 2.

$$L_f = 2 \times L = 2 \times 0.6 = 1.2 \text{ m}$$

$$e_2 = \frac{3 \times 1.2^2}{10^4 \times 0.1} (2 + 0) = 0.00432 \text{ m}$$

$$e = e_1 + e_a + e_2$$

$$e = 0.71 + 0.02 + 0.00432$$

$$e = 0.734 \text{ m}$$

IV.2.4.2 Filling coefficient :

$$\Psi = \frac{N_u}{b \times h \times f_{bc}} \leq 2/3$$

$$\Psi = \frac{2.61 \times 10^4}{1000 \times 100 \times 14.2} = 0.01838 < 2/3 \dots\dots\dots \text{C.V}$$

So:

$$\xi = \frac{1 + \sqrt{9 - 12\Psi}}{4(3 + \sqrt{9 - 12\Psi})}$$

$$\xi = 0.166$$

So :

$$e_{NC} = \xi \times h$$

$$e_{NC} = 0.1 \times 0.166 = 0.0167 \text{ m}$$

So : $e = 0.734 > e_{NC} = 0.0167 \dots\dots\dots \text{C.V}$

The section is partially compressed and the ULS may not be reached (low effort), the center of pressure is outside the section.

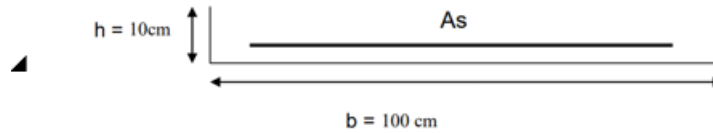
IV.2.4.3 Reinforcement section :*Figure IV.2 Reinforcement section (Parapet)***The fictional moment :**

$$M_{uf} = M_u + N_u \times \left(d - \frac{h}{2} \right)$$

$$d = h - \left(1 + \frac{\phi}{2} \right)$$

With:

$$\phi = \frac{h}{10} = 1$$

$$d = 10 - (1 + 0.5) = 8.5 \text{ cm}$$

$$M_{uf} = 1,875 + 2.61 \times \left(0.085 - \frac{0.1}{2} \right) = 1.97 \text{ KN.m}$$

$$\mu = \frac{M_{uf}}{bd^2 \sigma_{bc}}$$

$$\mu = \frac{1,97 \times 10^{-3}}{1 \times (0.085^2) \times 14,2} = 0,019 < 0,186 \longrightarrow \text{Pivot A}$$

$A_s' = 0$ (Compressed steel not required).

$$\sigma_s = \frac{f_e}{\gamma_s} = \frac{400}{1} = 400 \text{ MPa}$$

Single frame section:

$$A_{st} = \frac{1}{\sigma_s} \left(\frac{M_{uf}}{z} \right)$$

$$\left\{ \alpha = 1,25(1 - \sqrt{1 - 2\mu}) = 1,25(1 - \sqrt{1 - 2 \times 0,019}) = 0,023 \right.$$

$$\left\{ z = d \times (1 - 0,4\alpha) = 0,085 \times (1 - 0,4 \times 0,023) = 0,08 \text{ m} = 8,4 \text{ cm} \right.$$

As a result:

$$A_{sf} = \frac{1,97 \times 10}{0,08 \times 400}$$

$$A_{sf} = 0,615 \text{ cm}^2$$

With:

$$A_s = A_{sf} - \frac{N_u}{\sigma_s}$$

$$A_s = 61,5 - \frac{2,61 \times 10^3}{400} = 0,5497 \text{ cm}^2$$

$$A_s = 0,5497 \text{ cm}^2$$

IV.2.4.4 Non-fragility condition : (CBA93 art. A.4.2)

We have:
$$A_{st\ min} \geq 0,23 \times \frac{f_{t28}}{f_e} \times b.d$$

With:

$$f_{t28} = 0,6 + 0,06 f_{c28} = 2,1 \text{ MPa}$$

So:

$$A_{st\ min} \geq 0,23 \times \frac{2,1}{400} \times 0,085 \times 1$$

$$A_{st\ min} \geq 1,03 \times 10^{-4} \text{ m}^2$$

So:

$$A_{st\ min} = 1,03 \text{ cm}^2 > A_{st} = 0,5497 \text{ cm}^2$$

$$A_s = \max(A_{s\ min}, A_s) = 1,03 \text{ cm}^2$$

$$\text{We take: } 4T8 = 2,01 \text{ cm}^2 / \text{ml.}$$

We adopt a spacing of main reinforcement $S_t = 25 \text{ cm}$.

IV.2.4.5 Distribution armature :

$$A_r = \frac{A_{st}}{4}$$

So:

$$A_r = \frac{2,01}{4} = 0,50 \text{ cm}^2$$

$$\text{We take } 4T6 = 1,13 \text{ cm}^2 / \text{ml} \quad S = \frac{60}{4} = 15 \text{ cm}$$

We adopt a spacing of armature $S = 15 \text{ cm}$

IV.2.4.6 Verification of the shear condition (CBA 93 art A.5.1):

It must be checked that:
$$\tau_u \leq \bar{\tau}_u$$

$$T_{u\ max} = V_{max} = 2,81 \text{ KN}$$

$$\bar{\tau}_u = \min\left(0,15 \times \frac{f_{c28}}{\gamma_b}; 4 \text{ MPa}\right) = \min(2,5; 4 \text{ MPa}) = 2,5 \text{ MPa}$$

$$\tau_u = \frac{V_{max}}{b_0 \times d} = \frac{2,81 \times 10^{-3}}{1 \times 0,085} = 0,033 \text{ MPa} \leq \bar{\tau}_u = 2,5 \text{ MPa} \dots\dots\dots \text{CV}$$

So: Transverse reinforcement is not required.

Verification at SLS :

Since cracking is harmful, the stress of the steels must be checked, as well as in the concrete.

-The maximum compressive stress of concrete must not exceed the permissible limit:

$$\sigma_{bc} \leq \bar{\sigma}_{bc} = 0,6 \times f_{c28} = 15 \text{ MPa}$$

-The stress in tensioned steels does not exceed the permissible limit:

$$\sigma_s \leq \bar{\sigma}_s = \min(2/3f_e; 110\sqrt{\eta \times f_{t28}}) = 201,63 \text{ MPa (Harmful cracking)}$$

With:

$$\eta = 1.6$$

$$f_{t28} = 2.1 \text{ MPa}$$

And:

$$\sigma_s = 15 \times \frac{z \times N_s}{I} \times (d - y_{ser})$$

We solve the equation of the third degree:

$$z^3 + p \times z + q = 0$$

With:

$$e = \frac{M_{ser}}{N_{ser}} = \frac{1.25}{2.61} = 0.478 \text{ m}$$

$$c = \frac{h}{2} - e = 0.05 - 0.478 = -0.428 \text{ m}$$

c: The distance from the center of pressure and the most compressed fiber in the section.

$$p = -3c^2 - 90A'_s \times \frac{c-d'}{b} + 90A_s \times \frac{d-c}{b}$$

$$p = -3(-0.428)^2 + 90(2.01 \times 10^{-4}) \times \frac{0.085+0.428}{1} = -0.54 \text{ m}^2$$

$$q = -2c^3 - 90A'_s \times \frac{(c-d')^2}{b} - 90A_s \times \frac{(d-c)^2}{b}$$

$$q = -2(-0.428)^3 - 90(2.01 \times 10^{-4}) \times \frac{(0.085+0.428)^2}{1} = 0.152 \text{ m}^2$$

So, the equation is:

$$z^3 - 0.54 \times z + 0.152 = 0$$

$$\text{So: } z = -0.848 \text{ m}$$

$$0 \leq y_{ser} \leq d$$

$$y_{ser} = z + c = -0.848 - 0.428 = -1.276 \text{ m} < 0$$

So:

$$y = -D + \sqrt{D^2 + E}$$

With:

$$D = \frac{15}{b} (A_u + A_u')$$

$$D = \frac{15}{100} (0.5497 + 0) = 0.082 \text{ cm} \quad (A_u' = 0)$$

$$E = \frac{30}{b} (A_u \cdot d + A_u' \cdot d) = \frac{30}{100} \times (0.5497 \times 8.5 + 0) = 1.4 \text{ cm}^2$$

$$\text{So: } y = -0.082 + \sqrt{0.082^2 + 1.4} = 1.1 \text{ cm}$$

Calculation of moment of inertia :

$$I = \frac{b}{3} y_1^3 + 15 A_u (d - y_1)^2 + 15 A_u' (y_1 - d')^2$$

$$\text{So: } I = \frac{100}{3} \mathbf{1.1}^3 + 15 \times 0.5497 (8.5 - 1.1)^2 + 0 = 495.89 \text{ cm}^4$$

$$\text{With: } \sigma_{bc} = \frac{M_{ser}}{I} \times y = \frac{1.25 \times 10^2}{495.89} \times 1.1 = 2.77 \text{ MPa}$$

$$\sigma_{bc} = \mathbf{2.77 \text{ MPa}} \leq \overline{\sigma}_{bc} \dots\dots CV$$



Figure IV.3 Reinforcement scheme of parapet

IV.3 Dimensioning of hollow body floors :**III.3.1 Definition :**

The floor is the horizontal surface of the building or structure that provides a level space for walking, working or accommodating various activities. In this case they are made of concrete and it can be cast in place or prefabricated.

Floor type choice :

Floors play a crucial role in the overall structural integrity of a building, as they distribute loads from occupants, furniture, and equipment to the underlying structural elements, such as beams, columns, and foundations. Additionally, floors often incorporate elements such as insulation, finishes, and utility conduits (e.g., electrical wiring, plumbing) to meet the functional and aesthetic requirements of the building.

The studied structure consists of a floor with hollow body...

The hollow-body floor consists of the hollow-bodies as well as a compression slab and supports beams.

In our project we adopted a hollow slab with $20+5 = 25$ cm

III.3.2 Calculation of load-bearing elements of the hollow-body floor :

III.3.2.1 The compression slab :

According to CBA93, compression slab has a thickness of 5 cm. It is equipped with a bar grid whose grid size cannot be larger than:

- 20 cm for the reinforcement perpendicular to the ribs.
- 33 cm for reinforcement parallel to the ribs.

When the spacing “L” between rib axes is between 50 and 80 cm, the section A of the Reinforcements perpendicular to the ribs must be at least equal to:

$$A \geq 0.02 \times L \times \frac{200}{f_e} = \frac{4 \times L}{F_e}$$

In our case L = 65 cm; Fe = 400 MPa; ep = 5 cm.

Reinforcement perpendicular to the ribs :

$$A = \frac{4 \times L}{F_e} = \frac{4 \times 65}{400} = 0.65 \text{ cm} / \text{ml} \rightarrow \text{We choose } 5T6 = 1.41 \text{ cm}^2$$

Reinforcement parallel to the ribs :

$$A = \frac{1.41}{2} = 0.71 \text{ cm} / \text{ml} \rightarrow \text{we choose } 5T6 = 1.41 \text{ cm}^2$$

Spacing between reinforcements:

According to the RPA99 V 2003:

$$\frac{A_t}{S_t} \geq 0.003 b_0$$

$$S_t \leq \frac{A_t}{0.003 b_0} = 20 \text{ cm}$$

III.3.2.2 Study of girder :

Calculation method :

There are several methods that can be used in the calculation of this element in which cite as an example the flat-rate method, the method of Caquot, ...

- **Flat-rate method :**

The flat-rate method applies to beams, joists and slab supporting and moderate operating load ($Q \leq 2 \times G$ or $Q < 5000 \text{ N/cm}^2$).

This method to bending elements that meet the following conditions:

- The moment of inertia of the transvers sections are the same in the deferent spans in continuity.
- The successive spans are in a ratio between 0.8 and 1.25.
- The cracking dose not compromise the strength of the reinforced concrete or that of its coatings.

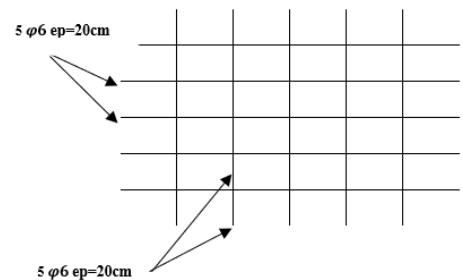

Figure IV.4 Arrangement of the compression slab reinforcement

In one of these three additional conditions is not satisfied, the calculation method for floors with a relatively high operating load can be applied (A. CAQUOT method)

Application of the method :

According to:

$$\alpha = \frac{Q_B}{G + Q_B}$$

α : it is the ratio between operating load and overloads

$$M_0 = \frac{q \times l^2}{8}$$

M_0 : it is the maximum value of the bending moment in span.

M_w and M_e : are the absolute values of the moments on the left (w) and the right (e) supports in the considered span.

M_t : the maximum moment in the span considered.

➤ **Moment on supports :**

- 0.6M₀ for a two-span beam.
- 0.5M₀ for the supports adjacent to the edge support of a beam with more than two spans.
- 0.4M₀ for other intermediate supports of a beam with more than 3 spans.

➤ **Shearing force :**

- $V_w = -2 \times \frac{M_w + M_t}{a}$
- $V_e = 2 \times \frac{M_e + M_t}{b}$

With:

a: Abscissa of the left support of the maximum moment, $a = \frac{L}{1 + \sqrt{\frac{M_e + M_t}{M_w + M_t}}}$

b: Abscissa of the right support of the maximum moment, $b = \frac{L}{1 + \sqrt{\frac{M_w + M_t}{M_e + M_t}}}$

• **Moment on span :**

The values M_t , M_w and M_e must verify the following conditions:

$$M_t \geq \text{Max} [1.05M_0, (1 + 0.3\alpha) M_0] - \frac{M_w + M_e}{2}$$

In an intermediate span: $M_t \geq \frac{1 + 0.3\alpha}{2} M_0$

In a side span: $M_t \geq \frac{1.2 + 0.3\alpha}{2} M_0$

Verification of the application of the flat-rate method

• **First condition :**

Moderate overload floor ($Q \leq \text{Min} (2G, 5 \text{ KN/m}^2)$).

Inaccessible terrace floor :

$$Q = 1\text{KN/m}^2, G = 6.28 \text{ KN/m}^2 \Rightarrow Q = 1\text{KN/m}^2 \leq \text{Min} (12.56; 5 \text{ KN/m}^2) \dots\dots \text{C.V}$$

Common floor :

$$Q = 1.5 \text{ KN/m}^2, G = 5.83 \text{ KN/m}^2 \Rightarrow Q = 1.5\text{KN/m}^2 \leq \text{Min} (11.66; 5 \text{ KN/m}^2) \dots\dots \text{C.V}$$

- **Seconde condition :**

The ratio between two successive spans: $0.8 \leq L_n / L_{n+1} \leq 1.25$

$$3.4/3.4 = 1 \Rightarrow 0.8 \leq 1 \leq 1.25 \dots\dots\dots \text{C. V}$$

$$3.4/3.4 = 1 \Rightarrow 0.8 \leq 1 \leq 1.25 \dots\dots\dots \text{C. V}$$

$$3.4/4.9 = 0.69 \Rightarrow 0.8 \leq 0.69 \leq 1.25 \dots\dots\dots \text{C.N. V}$$

Condition is not checked so we switch to the Caquot method.

- **Caquot method: (B.A.E.L91/99 art B.6.2)**

Application and principle of the method:

The Caquot method is based on the assumption that the load transmitted to a column from a slab is proportional to the column's relative stiffness compared to the stiffness of all the columns supporting the slab. It involves calculating the share of load carried by each column based on their relative stiffness.

The method applies mainly to beams - building floors this means for high operating loads:

$$q > 2g \text{ or } q > 5\text{KN/m}^2$$

It may also apply where one of the three conditions of the flat-rate method is not validated (Variable inertia; length dieresis between spans greater than 25%; harmful or very harmful cracking).

In this case, the reduced caquot which consists in taking $g' = 2/3g$ for the calculation of the moments on support.

Application of the method:

- **Moment in support:**

$$M_a = - \frac{q_w \times L'_w{}^3 + q_e \times L'_e{}^3}{8.5 \times (L'_w + L'_e)}$$

With:

q_w and q_e : loading to the left and the right of the support considered respectively.

L'_w and L'_e : Fictitious lengths to the left and the right of the support considered respectively.

- $L' = L$ for a side span.
- $L' = 0.8L$ for an intermediate span.

- **Shearing force:**

$$V_w = \frac{M_w - M_e}{L} - q \times \frac{L}{2}$$

$$V_e = V_w + q \cdot L$$

With:

M_e : moment on the right support of the considered span.

M_w : moment on the left support of the considered span.

L: length of span.

- **Moment on span:**

$$x_0 = -\frac{V_w}{q} \quad x_0 = \frac{L}{2} - (M_w - M_e)/q \times L$$

$$M_t = M_w - V_w \times x_0 - \frac{x_0^2 \times q}{2}$$

With:

M_w : moment on the left support of the considered span.

V_w : Shearing force on the left support of the considered span.

x_0 : Abscissa at the point of the moment is maximum.

Calculation of stresses:

Application of Caquot method calculation:

The girders are prefabricated elements, their calculation is associated with that of a continuous beam semi-recessed to the edge beams.

Taking into account the example of the common floor girder.

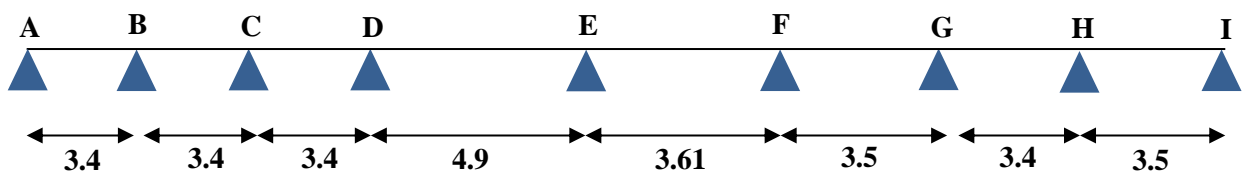

Figure IV.5 Type of girder

- **Calculation of loads and overloads:**

The combinations of actions and the calculation of the loads returning to the girder are given in the following table:

- **ULS:**

$$Q_u = (1.35G + 1.5Q) \times b$$

- **SLS:**

$$Q_{ser} = (G + Q) \times b$$

Table IV.1 Loads and overloads

Designation	G(KN/m ²)	G'	Q(KN/m ²)	ULS		SLS	
				q _u	q _u '	q _{ser}	q _{ser} '
Terrace floor	6.28	4.19	1	6.48	4.65	4.73	3.37
Common floor	5.83	3.89	1.5	6.6	4.87	4.44	3.50

a- **Moment in the supports :**

Moment in supports A, I :

The moment at the edge supports is equal to zero.

ULS : $M=0$ KN.m

SLS : $M=0$ KN.m

Moment in support B :

ULS :

$$M = - \frac{4.87 \times (4^3 + 2.72^3)}{8.5 \times (4 + 2.72)} = -7.17 \text{ KN.m}$$

SLS :

$$M = - \frac{3.50 \times (4^3 + 2.72^3)}{8.5 \times (4 + 2.72)} = -5.15 \text{ KN.m}$$

Moment in support C :

ULS :

$$M = - \frac{4.87 \times (2.72^3 + 2.72^3)}{8.5 \times (2.72 + 2.72)} = -4.24 \text{ KN.m}$$

SLS :

$$M = - \frac{3.50 \times (2.72^3 + 2.72^3)}{8.5 \times (2.72 + 2.72)} = -3.04 \text{ KN.m}$$

Moment in support D :**ULS :**

$$M = - \frac{4.87 \times (2.72^3 + 3.92^3)}{8.5 \times (2.72 + 3.92)} = -6.93 \text{ KN.m}$$

SLS :

$$M = - \frac{3.50 \times (2.72^3 + 3.92^3)}{8.5 \times (2.72 + 3.92)} = -4.98 \text{ KN.m}$$

Moment in support E :**ULS :**

$$M = - \frac{4.87 \times (3.92^3 + 2.89^3)}{8.5 \times (3.92 + 2.89)} = -7.09 \text{ KN.m}$$

SLS :

$$M = - \frac{3.50 \times (3.92^3 + 2.89^3)}{8.5 \times (3.92 + 2.89)} = -5.10 \text{ KN.m}$$

Moment in support F :**ULS :**

$$M = - \frac{4.87 \times (2.89^3 + 2.8^3)}{8.5 \times (2.89 + 2.8)} = -4.64 \text{ KN.m}$$

SLS :

$$M = - \frac{3.50 \times (2.89^3 + 2.8^3)}{8.5 \times (2.89 + 2.8)} = -3.33 \text{ KN.m}$$

Moment in support G :**ULS :**

$$M = - \frac{4.87 \times (2.8^3 + 2.72^3)}{8.5 \times (2.8 + 2.72)} = -4.37 \text{ KN.m}$$

SLS :

$$M = - \frac{3.50 \times (2.8^3 + 2.72^3)}{8.5 \times (2.8 + 2.72)} = -3.14 \text{ KN.m}$$

Moment in support H :**ULS :**

$$M = - \frac{4.87 \times (2.72^3 + 2.8^3)}{8.5 \times (2.72 + 2.8)} = -4.37 \text{ KN.m}$$

SLS :

$$M = - \frac{3.50 \times (2.72^3 + 2.8^3)}{8.5 \times (2.72 + 2.8)} = -3.14 \text{ KN.m}$$

b- Shear forces on spans :**Shear force on span A-B :****ULS :**

$$V_w = \frac{7.17}{3.4} - 6.6 \times \frac{3.4}{2} = -9.11 \text{ KN}$$

$$V_e = -9.11 + 6.6 \times 3.4 = 13.33 \text{ KN}$$

SLS :

$$V_w = \frac{5.15}{3.4} - 4.44 \times \frac{3.4}{2} = -6.03 \text{ KN}$$

$$V_e = -6.03 + 4.44 \times 3.4 = 9.07 \text{ KN}$$

Shear force on span B-C :**ULS :**

$$V_w = \frac{-7.17+4.24}{3.4} - 6.6 \times \frac{3.4}{2} = -12.08 \text{ KN}$$

$$V_e = -12.08 + 6.6 \times 3.4 = 10.36 \text{ KN}$$

SLS :

$$V_w = \frac{-5.15+3.04}{3.4} - 4.44 \times \frac{3.4}{2} = -8.17 \text{ KN}$$

$$V_e = -8.17 + 4.44 \times 3.4 = 6.93 \text{ KN}$$

Shear force on span C-D :**ULS :**

$$V_w = \frac{-4.24+6.93}{3.4} - 6.6 \times \frac{3.4}{2} = -10.43 \text{ KN}$$

$$V_e = -10.43 + 6.6 \times 3.4 = 12.01 \text{ KN}$$

SLS :

$$V_w = \frac{-3.04+4.98}{3.4} - 4.44 \times \frac{3.4}{2} = -6.98 \text{ KN}$$

$$V_e = -6.98 + 4.44 \times 3.4 = 8.12 \text{ KN}$$

Shear force on span D-E :**ULS :**

$$V_w = \frac{-6.93+7.09}{4.9} - 6.6 \times \frac{4.9}{2} = -16.14 \text{ KN}$$

$$V_e = -16.14 + 6.6 \times 4.9 = 16.2 \text{ KN}$$

SLS :

$$V_w = \frac{-4.98+5.10}{4.9} - 4.44 \times \frac{4.9}{2} = -10.85 \text{ KN}$$

$$V_e = -10.85 + 4.44 \times 4.9 = 10.90 \text{ KN}$$

Shear force on span E-F :**ULS :**

$$V_w = \frac{-7.09+4.64}{3.61} - 6.6 \times \frac{3.61}{2} = -12.59 \text{ KN}$$

$$V_e = -12.59 + 6.6 \times 3.61 = 11.24 \text{ KN}$$

SLS :

$$V_w = \frac{-5.10+3.33}{3.61} - 4.44 \times \frac{3.61}{2} = -8.50 \text{ KN}$$

$$V_e = -8.50 + 4.44 \times 3.61 = 7.53 \text{ KN}$$

Shear force on span F-G :**ULS :**

$$V_w = \frac{-4.64+4.37}{3.5} - 6.6 \times \frac{3.5}{2} = -11.63 \text{ KN}$$

$$V_e = -11.63 + 6.6 \times 3.5 = 11.47 \text{ KN}$$

SLS :

$$V_w = \frac{-3.33+3.14}{3.5} - 4.44 \times \frac{3.5}{2} = -7.82 \text{ KN}$$

$$V_e = -7.82 + 4.44 \times 3.5 = 7.72 \text{ KN}$$

Shear force on span G-H :**ULS :**

$$V_w = \frac{-4.37+4.37}{3.4} - 6.6 \times \frac{3.4}{2} = -11.22 \text{ KN}$$

$$V_e = -11.22 + 6.6 \times 3.4 = 11.22 \text{ KN}$$

SLS :

$$V_w = \frac{-3.14+3.14}{3.4} - 4.44 \times \frac{3.4}{2} = - 7.55 \text{ KN}$$

$$V_e = - 7.55 + 4.44 \times 3.4 = 7.55 \text{ KN}$$

Shear force on span H-I :**ULS :**

$$V_w = \frac{-4.37}{3.5} - 6.6 \times \frac{3.5}{2} = - 12.80 \text{ KN}$$

$$V_e = - 12.80 + 6.6 \times 3.5 = 10.3 \text{ KN}$$

SLS :

$$V_w = \frac{-3.14}{3.5} - 4.44 \times \frac{3.5}{2} = - 8.67 \text{ KN}$$

$$V_e = - 8.67 + 4.44 \times 3.5 = 6.87 \text{ KN}$$

c- Moments on spans :**Moment on span A-B :****ULS :**

$$x_0 = \frac{9.11}{6.6} = 1.38 \text{ m}$$

$$M_t = 0 + 9.11 \times 1.38 - \frac{1.38^2 \times 6.6}{2} = 6.28 \text{ KN.m}$$

SLS :

$$x_0 = \frac{6.03}{4.44} = 1.36 \text{ m}$$

$$M_t = 0 + 6.03 \times 1.36 - \frac{1.36^2 \times 4.44}{2} = 4.09 \text{ KN.m}$$

Moment on span B-C :**ULS :**

$$x_0 = \frac{12.08}{6.6} = 1.83 \text{ m}$$

$$M_t = -7.17 + 12.08 \times 1.83 - \frac{1.83^2 \times 6.6}{2} = 3.88 \text{ KN.m}$$

SLS :

$$x_0 = \frac{8.17}{4.44} = 1.84 \text{ m}$$

$$M_t = -5.15 + 8.17 \times 1.84 - \frac{1.84^2 \times 4.44}{2} = 2.37 \text{ KN.m}$$

Moment on span C-D :**ULS :**

$$x_0 = \frac{10.43}{6.6} = 1.58 \text{ m}$$

$$M_t = -4.24 + 10.43 \times 1.58 - \frac{1.58^2 \times 6.6}{2} = 4.00 \text{ KN.m}$$

SLS :

$$x_0 = \frac{6.98}{4.44} = 1.57 \text{ m}$$

$$M_t = -3.04 + 6.98 \times 1.57 - \frac{1.57^2 \times 4.44}{2} = 2.45 \text{ KN.m}$$

Moment on span D-E :**ULS :**

$$x_0 = \frac{16.14}{6.6} = 2.44 \text{ m}$$

$$M_t = -6.93 + 16.14 \times 2.44 - \frac{2.44^2 \times 6.6}{2} = 12.80 \text{ KN.m}$$

SLS :

$$x_0 = \frac{10.85}{4.44} = 2.44 \text{ m}$$

$$M_t = -4.98 + 10.85 \times 2.44 - \frac{2.44^2 \times 4.44}{2} = 8.28 \text{ KN.m}$$

Moment on span E-F :**ULS :**

$$x_0 = \frac{12.59}{6.6} = 1.90 \text{ m}$$

$$M_t = -7.09 + 12.59 \times 1.9 - \frac{1.9^2 \times 6.6}{2} = 4.92 \text{ KN.m}$$

SLS :

$$x_0 = \frac{8.50}{4.44} = 1.91 \text{ m}$$

$$M_t = -5.10 + 8.50 \times 1.91 - \frac{1.91^2 \times 4.44}{2} = 3.04 \text{ KN.m}$$

Moment on span F-G :**ULS :**

$$x_0 = \frac{11.63}{6.6} = 1.76 \text{ m}$$

$$M_t = -4.64 + 11.63 \times 1.76 - \frac{1.76^2 \times 6.6}{2} = 5.61 \text{ KN.m}$$

SLS :

$$x_0 = \frac{7.82}{4.44} = 1.76 \text{ m}$$

$$M_t = -3.33 + 7.82 \times 1.76 - \frac{1.76^2 \times 4.44}{2} = 3.56 \text{ KN.m}$$

Moment on span G-H :**ULS :**

$$x_0 = \frac{11.22}{6.6} = 1.7 \text{ m}$$

$$M_t = -4.37 + 11.22 \times 1.7 - \frac{1.7^2 \times 6.6}{2} = 5.17 \text{ KN.m}$$

SLS :

$$x_0 = \frac{7.55}{4.44} = 1.7 \text{ m}$$

$$M_t = -3.14 + 7.55 \times 1.7 - \frac{1.7^2 \times 4.44}{2} = 3.28 \text{ KN.m}$$

Moment on span H-I :**ULS :**

$$x_0 = \frac{12.80}{6.6} = 1.94 \text{ m}$$

$$M_t = -4.37 + 12.80 \times 1.94 - \frac{1.94^2 \times 6.6}{2} = 8.04 \text{ KN.m}$$

SLS :

$$x_0 = \frac{8.67}{4.44} = 1.95 \text{ m}$$

$$M_t = -3.14 + 8.67 \times 1.95 - \frac{1.95^2 \times 4.44}{2} = 5.32 \text{ KN.m}$$

- **Calculation of reinforcement :**

The girder will be reinforced according to the maximum stresses, for this we distinguish:

Table IV.2 The maximum stresses in the girder

Types of girders	ULS			SLS		
	M_{tu} (KN.m)	M_{au} (KN.m)	V (KN)	M_{ts} (KN.m)	M_{as} (KN.m)	V (KN)
Type 1	12.80	7.17	16.14	8.28	5.15	10.85

The girder reinforcement is done at the ULS for a section in T in simple bending.

✓ The moment of the table M_{tab} :

The geometric characteristics of the girder are:

$$b = 65 \text{ cm} \quad b_0 = 10 \text{ cm} \quad h = 20 \text{ cm} \quad h_0 = 4 \text{ cm} \quad d = 0.9 \times h = 18 \text{ cm}$$

$$M_{tab} = f_{bc} \times b \times \mu_0 \times d^2$$

$$\alpha_0 = \frac{h_0}{d}$$

$$\mu_0 = 1.14\alpha_0 - 0.57\alpha_0^2 - 0.07$$

On span :

$$\alpha_0 = \frac{4}{18}$$

$$\alpha_0 = 0.222 \rightarrow \alpha_0 \leq 0.259 \text{ Pivot A}$$

$$\mu_0 = 1.14 \times 0.222 - 0.57 \times 0.222^2 - 0.07 = 0.155$$

$$M_{tab} = 0.155 \times 0.65 \times 0.18^2 \times 14.2 = 0.04635 \text{ MN.m}$$

$$M_{tab} = 46.35 \text{ KN.m}$$

So, the neutral axis is in the compression table therefore the calculation is done as a rectangular section ($b=65 \times h=20$) subjected at bending moment.

$$\mu = \frac{M_{tu}}{b \cdot d^2 \cdot f_{bc}}$$

$$\mu = \frac{12.80 \times 10^{-3}}{0.65 \times 0.18^2 \times 14.2} = 0.042 \leq \mu_l = 0.392 \quad (A'_s = 0)$$

$$\mu = 0.036 < \mu = 0.186 \Rightarrow \text{pivot (A)}$$

$$\alpha = 1.25 \times (1 - \sqrt{1 - 2 \times 0.042}) = 0.053$$

$$\beta = (1 - 0.4\alpha)$$

$$\beta = (1 - 0.4 \times 0.053) \rightarrow \beta = 0.98$$

$$A_s = \frac{12.80 \times 10^4}{0.98 \times 18 \times 348 \times 10} = 2.08 \text{ cm}^2$$

$$\text{We take: } 3T10 \Rightarrow A_s = 2.36 \text{ cm}^2$$

On support :

$$\mu = \frac{7.17 \times 10^{-3}}{0.10 \times 0.18^2 \times 14.2} = 0.155 \leq \mu_l = 0.392 \quad (A_s = 0)$$

$$\mu = 0.155 < \mu = 0.186 \Rightarrow \text{pivot (A)}$$

$$\alpha = 1.25 \times (1 - \sqrt{1 - 2 \times 0.155}) = 0.211$$

$$\beta = (1 - 0.4\alpha)$$

$$\beta = (1 - 0.4 \times 0.211) \rightarrow \beta = 0.915$$

$$A_s = \frac{7.17 \times 10^4}{0.915 \times 18 \times 348 \times 10} = 1.25 \text{ cm}^2$$

We take: 2T10 $\Rightarrow A_s = 1.57 \text{ cm}^2$

- **Condition of non-fragility :**

On span :

$$A_{s \min} \leq A_s$$

$$A_{s \min} = \frac{0.23 \times b \times d \times f_{t28}}{f_e} = \frac{0.23 \times 0.65 \times 0.18 \times 2.1}{400} = 1.41 \text{ cm}^2 \leq A_s = 2.36 \text{ cm}^2 \dots\dots\dots \text{CV}$$

On support :

$$A_{s \min} = \frac{0.23 \times b_0 \times d \times f_{t28}}{f_e} = \frac{0.23 \times 0.1 \times 0.18 \times 2.1}{400} = 0.22 \text{ cm}^2 \leq A_s = 1.57 \text{ cm}^2 \dots\dots\dots \text{CV}$$

Transverse reinforcement :

$$\phi_t \leq \min \left\{ \phi_l, \frac{ht}{35}; \frac{b_0}{10} \right\}$$

$$\phi_t = \min \left\{ 10; \frac{200}{35} = 5.71; \frac{100}{10} = 10 \right\} = 5.71 \text{ mm}$$

We take: $\phi_t = 8 \text{ mm}$

We choose: 2HA8 = 1.01 cm^2

Spacing between reinforcement :

Nodal zone :

$$S_t = \min (h/4; 12\phi_l)$$

$$S_t = \min \left(\frac{200}{4} = 50 \text{ mm}; 12 \times 8 = 120 \text{ mm} \right) = 50 \text{ mm} = 5 \text{ cm}$$

We take : $S_t = 5 \text{ cm}$

Current zone :

$$S_t \leq h/2 = 200/2 = 100 \text{ mm} = 10 \text{ cm}$$

We take : $S_t = 10 \text{ cm}$

- Verification of the shear force:

$$\text{The tangent stress: } \tau = \frac{T_u}{b.d} \leq \bar{\tau}_u = \min \left\{ \frac{0.2 \times f_{c28}}{\gamma_b}; 5 \text{ MPa} \right\}$$

$$T_u = 16.14 \text{ KN}$$

$$\tau = \frac{T_u}{b.d} = \frac{16.14 \times 10^3}{100 \times 180} = 0.89 \text{ MPa}$$

$$\bar{\tau}_u = \min \left\{ \frac{0.2 \times f_{c28}}{\gamma_b}; 5 \text{ MPa} \right\} = \min \{ 3.33; 5 \text{ MPa} \} = 3.33 \text{ MPa}$$

$$\tau = 0.89 \leq \bar{\tau}_u = 3.33 \rightarrow \text{C. V}$$

It's checked, so there's no danger of rupture.

○ Verification S.L.S:

If the following conditions apply, the SLS check will not be necessary:

- The cracking is little harmful.....C.V
- The stress applied is at simple bendingC.V
- The steel used are of a grade of FeE400..... C. V
- The section is rectangular C.V

○ Verification of maximum concrete :

• On span :

$$\alpha = 0.053 \leq \frac{\delta-1}{2} + \frac{f_{c28}}{100}$$

$$\delta = \frac{M_u}{M_s} = \frac{12.80}{7.17} = 1.78$$

$$\frac{\delta-1}{2} + \frac{f_{c28}}{100} = \frac{1.78-1}{2} + \frac{25}{100} = 0.64$$

$$0.053 \leq 0.64 \dots\dots\dots CV$$

• On support :

$$\alpha = 0.211 \leq \frac{\delta-1}{2} + \frac{f_{c28}}{100}$$

$$\delta = \frac{M_u}{M_s} = \frac{7.17}{5.15} = 1.39$$

$$\frac{\delta-1}{2} + \frac{f_{c28}}{100} = \frac{1.39-1}{2} + \frac{25}{100} = 0.445$$

$$0.211 \leq 0.445 \dots\dots\dots CV$$

All conditions are checked so there is no verification at SLS.

○ Arrow check : (CBA93 B.6.8.4.2.4)

If the conditions mentioned below are verified, it is not necessary to verify the arrow.

$$\frac{h}{L} \geq \frac{1}{22.5} \Rightarrow \frac{0.20}{4.49} = 0.045 \geq \frac{1}{22.5} = 0.044 \dots\dots\dots CV$$

$$\frac{A_s}{b.d} \leq \frac{3.6}{f_e} \Rightarrow \frac{2.36}{65 \times 18} = 0.002 \leq \frac{3.6}{400} = 0.009 \dots\dots\dots CV$$

$$\frac{h}{L} \geq \frac{1}{15} \left(\frac{M_t}{M_0} \right) \Rightarrow \frac{0.20}{4.49} = 0.045 \geq \frac{1}{15} \left(\frac{8.28}{13.32} \right) = 0.041 \dots\dots\dots CV$$

All conditions are checked, so checking the arrow is not necessary.

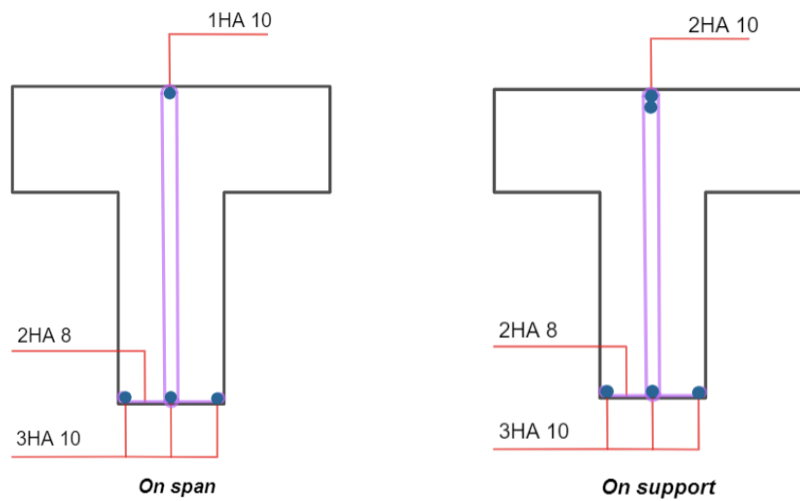

Figure IV.6 Reinforcement of the girder

IV.4 Staircase dimensioning :

A staircase is a structure comprising a series of steps or flights that allow people to ascend or descend between different levels within a building or structure. It is made of: The landing, a bench and the flight.

- The landing: the horizontal part of a staircase, stopping the rest of the steps to the right of a floor
- The bench: it is the slab of the lower solid part of the flight of a staircase.
- The flight: the succession of steps and counter steps.

Dimensioning a staircase involves determining the dimensions of each component of the staircase, including the width, height, depth of treads, and rise of steps.

IV.4.1 Calculation hypothesis :

- The stairs are sheltered from bad weather, so cracking will be considered as not very harmful, which leads to a reinforcement calculation at U.L.S followed by a stress check at S.L.S.
- The flight-landing assembly will be considered as a simply bent beam of unit width, and bi-articulated at its to ends for the calculation of the moment of the isostatic span. This moment will be broken down into the span and on the supports by continuity coefficients which consider the embedding effect at the ends of this beam.

IV.4.2 Evaluation of loads and over loads for 1 ml :

According to the evaluation of the loads of the elements previously estimated, the stairs support the above loads:

Table IV.3 Evaluation of loads of staircase

Element	G (KN/m ²)	Q(KN/m ²)	Nu=1.35G+1.5Q (KN/ml)	Nser=G+Q (KN/ml)
Flight	8.15	2.5	14.75	10.65
Landing	5.31	2.5	10.92	7.81

IV.4.3 Calculation of the staircase :

IV.4.3.1 Calculation of the equivalent load :

U.L.S :

$$Q_{u eq} = \frac{\sum Q_{ui} \times L_i}{\sum L_i}$$

$$Q_{u eq} = \frac{14.75 \times 2.4 + 10.92 \times 1.2}{2.4 + 1.2} = 13.47 \text{ KN/ml}$$

$$M_0 = \frac{Q_{u eq} \times L^2}{8}$$

$$M_0 = \frac{13.47 \times 12.96}{8} = 21.82 \text{ KN.m}$$

S.L.S :

$$Q_{s eq} = \frac{\sum Q_{si} \times L_i}{\sum L_i}$$

$$Q_{s eq} = \frac{10.65 \times 2.4 + 7.81 \times 1.2}{2.4 + 1.2} = 9.70 \text{ KN/ml}$$

$$M_0 = \frac{Q_{s eq} \times L^2}{8}$$

$$M_0 = \frac{9.70 \times 12.96}{8} = 15.71 \text{ KN.m}$$

IV.4.3.2 Isostatic moment of the console :

U.L.S :

The moment in spans: $M_{span} = 0.85M_u = 0.85 \times 21.82 = 18.55 \text{ KN.m}$

The moment in supports: $M_{supp} = -0.3 \times M_u = -0.3 \times 21.82 = -6.55 \text{ KN.m}$

The shear force: $T_u = Q_{ueq} \times \frac{L}{2} = 13.47 \times \frac{3.6}{2} = 24.25 \text{ KN}$

S.L.S :

The moment in spans: $M_{span} = 0.85M_{ser} = 0.85 \times 15.71 = 13.35 \text{ KN.m}$

The moment in supports: $M_{supp} = -0.3 \times M_{ser} = -0.3 \times 15.71 = -4.71 \text{ KN.m}$

The shear force: $T_s = Q_{ser} \times \frac{L}{2} = 9.70 \times \frac{3.6}{2} = 17.46 \text{ KN}$

IV.4.4 Reinforcement :**IV.4.4.1 Longitudinal reinforcement :****U.L.S :**

The calculation of reinforcement is done in simple bending, the cracking considered as being not very harmful.

$$f_{c28}=25\text{MPa.}$$

$$b= 100 \text{ cm.}$$

$$d = h - \left(1 + \frac{\phi}{2}\right) \text{ With: } \phi = \frac{h}{10} = 1.5$$

$$d = 15 - \left(1 + \frac{1.5}{2}\right) = 13.25 \text{ cm}$$

Steel: FeE400 type.

$$\sigma_s = 348 \text{ MPa.}$$

➤ In span :

$$M_{u \text{ span}} = 18.55 \text{ KN.m}$$

$$\mu_u = \frac{M_{u \text{ span}}}{b \cdot d^2 \cdot f_{bu}} = \frac{18.55 \times 10^3}{100 \times 13.25^2 \times 14.2} = 0.074 \quad \rightarrow \text{ pivot A}$$

$$\mu = 0.074 < \mu_l = 0.392 \quad \dots\dots CV$$

That is mean we are in pivot A, so:

A' = 0 no compressed reinforcement

$$\alpha = 1.25 \times (1 - \sqrt{1 - 2\mu}) = 1.25 \times (1 - \sqrt{1 - 2 \times 0.07}) = 0.09$$

$$\beta = (1 - 0.4\alpha) = (1 - 0.4 \times 0.09) = 0.964$$

$$\beta = 0.964$$

$$A_u = \frac{M_{u \text{ span}}}{\beta \cdot d \cdot \sigma_s}$$

$$A_u = \frac{18.55 \times 10^3}{0.964 \times 13.25 \times 348} = 4.17 \text{ cm}^2$$

$$A_u = 4.17 \text{ cm}^2$$

IV.4.4.2 Non-fragile condition :

$$A_{min} = 0.23 \times b \times d \times \frac{f_{t28}}{f_e} = 0.23 \times 100 \times 13.25 \times \frac{2.1}{400}$$

$$A_{min} = 1.6 \text{ cm}^2$$

$$A = \text{Max}(A_u, A_{min})$$

$$A = \text{Max}(4.17, 1.6) = 4.17 \text{ cm}^2$$

With that we adopt: **5HA12 = 5.65 cm²**

IV.4.4.3 Distribution reinforcement :

$$A_{dist} = \frac{A}{4}$$

$$A_{dist} = \frac{5.65}{4} = 1.412 \text{ cm}^2$$

So, we adopt **5HA8 = 2.51 cm²**

➤ **On support :**

$$M_{u \text{ sup}} = 6.55 \text{ KN.m}$$

$$\mu_u = \frac{M_{u \text{ span}}}{b \cdot d^2 \cdot f_{bu}} = \frac{6.55 \times 10^3}{100 \times 13.25^2 \times 14.2} = 0.026$$

$\mu = 0.026 < \mu_l = 0.259 \dots\dots$ $A' = 0$ no compressed reinforcement

$$\alpha = 1.25 \times (1 - \sqrt{1 - 2\mu}) = 1.25 \times (1 - \sqrt{1 - 2 \times 0.026}) = 0.032$$

$$\beta = (1 - 0.4\alpha) = (1 - 0.4 \times 0.031) = 0.9872$$

$$\rightarrow \beta = 0.9872$$

$$A_u = \frac{M_{u \text{ span}}}{\beta \cdot d \cdot \sigma_s}$$

$$A_u = \frac{6.55 \times 10^3}{0.9872 \times 13.25 \times 348} = 1.44 \text{ cm}^2$$

➤ **Non-fragile condition :**

$$A_{min} = 1.6 \text{ cm}^2$$

$$A = \text{Max}(A_u, A_{min}) = \text{Max}(1.41; 1.6) = 1.6 \text{ cm}^2$$

$$A = 1.6 \text{ cm}^2$$

With that we adopt: **4HA12 = 4.52 cm²**

➤ **Distribution reinforcement:**

$$A_{dist} = \frac{A}{4}$$

$$A_{dist} = \frac{4.52}{4} = 1.13 \text{ cm}^2$$

So, we adopt: **5HA8 = 2.51 cm²**

➤ **Spacing: (CBA93 article A.5.1.2.2)**

$$S_t \leq \min(3 \times h ; 33 \text{ cm})$$

$$S_t \leq \min(39.75 \text{ cm} ; 33 \text{ cm})$$

$$S_t \leq 33 \text{ cm}$$

So, we take $S_t = 20 \text{ cm}$

Table IV.4 Main reinforcements of staircase

Element	A_u (cm ²)	A_{min} (cm ²)	A_{adopt} (cm ²)	chois	S_t (cm)	A_{dis} (cm ²)	chois	S_t (cm)
Span	4.17	1.6	5.65	5HA12	20	1.412	5HA8	20
Support	1.44	1.6	2.51	4HA12	20	1.13	5HA8	20

IV.4.4.5 Verification of the shear force: (harmful cracking)

$$\tau = \frac{T_u}{b.d} \leq \bar{\tau}_u = \min\left\{\frac{0.2 \times f_{c28}}{\gamma_b} ; 5MPa\right\}$$

$T_u = 17.46$ KN

$$\tau = \frac{T_u}{b.d} = \frac{17.46}{1 \times 13.25}$$

$$\tau = 1.318 \text{ MPa}$$

$$\bar{\tau}_u = \min\left\{\frac{0.2 \times f_{c28}}{\gamma_b} ; 5MPa\right\} = \min\{3.33 ; 5MPa\} = 3.33 \text{ MPa}$$

$$\tau = 1.318 \text{ MPa} \leq \bar{\tau}_u = 3.33 \text{ MPa} \dots\dots \text{C.V}$$

IV.4.5 Verification S.L.S:

If the following conditions apply, the SLS check will not be necessary:

- The cracking is little harmful.....C.V
- The stress applied is at simple bendingC.V
- The steel used are of a grade of FeE400.....C.V
- The section is rectangular C.V

IV.4.5.1 Verification of maximum concrete:

- **On span:**

$$\alpha = 0.102 \leq \frac{\delta - 1}{2} + \frac{f_{c28}}{100}$$

With:

$$\delta = \frac{M_u}{M_s}$$

$$\delta = \frac{18.55}{13.35} = 1.39$$

$$\frac{\delta - 1}{2} + \frac{f_{c28}}{100} = \frac{1.39 - 1}{2} + \frac{25}{100} = 0.445$$

$$0.102 \leq 0.445 \dots\dots \text{C.V}$$

- **On support:**

$$\alpha = 0.047 \leq \frac{\delta - 1}{2} + \frac{f_{c28}}{100}$$

$$\delta = \frac{M_u}{M_s} = \frac{6.55}{4.71} = 1.39$$

With:

$$\frac{\delta-1}{2} + \frac{f_{c28}}{100} = \frac{1.39-1}{2} + \frac{25}{100} = 0.445$$

$$0.047 \leq 0.445 \dots\dots\dots \text{C.V}$$

All conditions are checked so there is no verification at SLS.

IV.4.5.2 Verification of deflection calculation condition : CBA 93 (art B.6.5.1)

$$\bullet \frac{h}{l} \geq \max \left(\frac{1}{16}; \frac{M_t}{10M_0} \right)$$

$$\frac{15}{360} \geq \max \left(\frac{1}{16}; \frac{18.55}{10 \times 21.82} \right)$$

$$0.042 \geq \max (0.0625; 0.085)$$

$$0.0378 \geq 0.085 \dots\dots\dots \text{CNV}$$

$$\bullet \frac{A}{b.d} \leq \frac{4.2}{f_e}$$

$$\frac{5.65}{100 \times 13.25} = 0.0043 \leq \frac{4.2}{400} = 0.0105 \dots\dots\dots \text{CV}$$

We must check the arrow:

According to the RDM the arrow is calculated by the relation: $\frac{5.q.l^4}{348.E.I}$ With:

E: Modulus of deferred deformation $E_{vj} = 1.08 \times 10^4$

I: Moment of inertia $I = \frac{b.h^3}{12} = \frac{100.15^3}{12} = 28125 \text{ cm}^4$

$$\text{So: } f = \frac{5 \times 10.65 \times 3.6^4}{348 \times 1.08 \times 10^4 \times 28125} = 0.08 \text{ cm}$$

$$f_{ad} = \frac{l}{500} = \frac{360}{500} = 0.72 \text{ cm}$$

$$f = 0.08 \text{ cm} < f_{ad} = 0.72 \text{ cm} \rightarrow \text{C.V}$$

IV.4.5.3 Load assessment :

The self-weight of the landing beam:

$$G_{\text{landing beam}} = 25 \times 0.40 \times 0.40 = 4 \text{ KN/ml}$$

Walls placed on the landing beam:

$$G_{\text{wall}} = \left(\frac{h_e}{2} - h \right) \times g_{\text{wall}}$$

$$G_{\text{wall}} = \left(\frac{3.06}{2} - 0.40 \right) \times 2.93$$

$$G_{\text{wall}} = 3.31 \text{ KN/m}$$

IV.4.5.4 Landing and bench reaction :

$$\underline{\text{U.L.S}} : R_u = \frac{P_{eu} \times L}{2} = \frac{13.47 \times 3.6}{2} = 24.25 \text{ KN/m}$$

$$\underline{\text{S.L.S}} : R_s = \frac{P_{es} \times L}{2} = \frac{9.70 \times 3.6}{2} = 17.5 \text{ KN/m}$$

IV.4.5.5 Action combination :**U.L.S**

$$q_u = 1.35 G_T + R_u$$

$$q_u = 1.35 \times (G_{wall} + G_{landing\ beam}) + R_u = 1.35 \times (3.31 + 4) + 24.25 = 34.12 \text{ KN/m}$$

$$q_u = 34.12 \text{ KN/m}$$

S.L.S

$$q_s = G_T + R_s$$

$$q_s = G_{wall} + G_{landing\ beam} + R_s = 24.81 \text{ KN/m}$$

$$q_s = 24.81 \text{ KN/m}$$

IV.3.5.6 Stresses on the landing beam :**➤ Isostatic moment :****ULS :**

$$M_0 = \frac{ql^2}{8}$$

$$M_0 = \frac{34.12 \times 3.6^2}{8} = 55.28 \text{ KN.m}$$

SLS :

$$M_0 = \frac{24.81 \times 3.6^2}{8} = 40.2 \text{ KN.m}$$

➤ Bending moment :**ULS :**

$$M_t = 0.85 M_0 = 0.85 \times 55.28 = 46.98 \text{ KN.m}$$

$$M_a = 0.3 M_0 = 0.3 \times 55.28 = 16.58 \text{ KN.m}$$

SLS :

$$M_t = 0.85 M_0 = 0.85 \times 40.2 = 34.17 \text{ KN.m}$$

$$M_a = 0.3 M_0 = 0.3 \times 40.2 = 12.06 \text{ KN.m}$$

➤ Shear force :

$$T_u = \frac{q_u \times l}{2} = \frac{34.12 \times 3.6}{2} = 61.42 \text{ KN}$$

IV.3.5.7 Reinforcement :**➤ U.L.S :**

The landing beam works in simple bending, therefore:

$$f_{bu} = \frac{0.85 \times f_{c28}}{\gamma_b} = 14.16 \text{ MPa}$$

With:

$$\sigma_s = 348 \text{ MPa}, d = 0.9 h = 0.9 \times 40 = 36 \text{ cm}, b = 40 \text{ cm}$$

$$\mu_u = \frac{M_u}{b \cdot d^2 \cdot f_{bu}}; A_u = \frac{M_u}{\beta \cdot d \cdot \sigma_s}; A_{min} = 0.23 \times b \times d \times \frac{f_{t28}}{f_e}; A = \text{Max}(A_u, A_{min})$$

• **On span :**

$$\mu_u = \frac{46.98 \times 10^3}{40 \times 36^2 \times 14.2} = 0.063 \leq \mu_l = 0.392 (A'_s = 0)$$

$$\mu = 0,063 < \mu = 0,186 \Rightarrow \text{pivot (A)}$$

$$\alpha = 1.25 \times (1 - \sqrt{1 - 2 \times 0.063}) = 0.081$$

$$\beta = (1 - 0.4\alpha) \rightarrow \beta = 0.9676$$

$$A_s = \frac{46.98 \times 10^3}{0.9676 \times 36 \times 348} = 3.88 \text{ cm}^2$$

➤ **Condition of non-fragility : (CBA93 art A.4.2)**

$$A_{s \text{ min}} \leq A_s$$

$$A_{s \text{ min}} = \frac{0.23 \times b \times d \times f_{t28}}{f_e} = 1.74 \text{ cm}^2$$

$$A_{s \text{ min}} = 1.74 \text{ cm}^2 \leq A_s = 3.88 \text{ cm}^2 \rightarrow \text{C.V}$$

We choose **3T14 = 4.62 cm²**

• **In support :**

$$\mu_u = \frac{16.58 \times 10^3}{40 \times 36^2 \times 14.2} = 0.022 \leq \mu_l = 0.392 (A'_s = 0)$$

$$\mu = 0,022 < \mu = 0,186 \Rightarrow \text{pivot (A)}$$

$$\alpha = 1.25 \times (1 - \sqrt{1 - 2 \times 0.022}) = 0.028$$

$$\beta = (1 - 0.4\alpha) \rightarrow \beta = 0.9888$$

$$A_s = \frac{16.58 \times 10^3}{0.9888 \times 36 \times 348} = 1.34 \text{ cm}^2$$

➤ **Condition of non-fragility :**

$$A = \text{Max}(A_u, A_{min})$$

$$A_{s \text{ min}} = \frac{0.23 \times b \times d \times f_{t28}}{f_e} = 1.74 \text{ cm}^2 \leq 1.34 \text{ cm}^2 \dots\dots\dots \text{CNV}$$

$$\rightarrow A_s = A_{s \text{ min}} = 1.74 \text{ cm}^2$$

We choose: **3T14 = 4.62 cm²**

➤ **Distribution reinforcement :**

$$A_r = \frac{A_s}{4}$$

$$A_r = \frac{4.62}{4} = 1.155 \text{ cm}^2$$

we choose: 4T8=2.01cm²

➤ **Spacing :**

-In the nodal zone:

$$e \leq \min (h/4 ; 12\varphi)$$

$$e \leq \min (10; 16.8) = 10 \text{ cm}$$

we take e = 6 cm

-Outside the nodal zone:

$$e \leq (h/2) = 20 \text{ cm}$$

we take e = 15 cm

➤ **Verification of the shear force :**

The tangent stress:

$$\tau = \frac{T_u}{b.d} \leq \bar{\tau}_u = \min \left\{ \frac{0.2 \times f_{c28}}{\gamma_b} ; 5 \text{ MPa} \right\}$$

$$T = 61.42 \text{ KN}$$

$$\tau = \frac{T_u}{b.d} = \frac{61.42 \times 10^{-3}}{0.4 \times 0.36} = 0.43 \text{ MPa}$$

$$\bar{\tau}_u = \min \left\{ \frac{0.2 \times f_{c28}}{\gamma_b} ; 5 \text{ MPa} \right\} = \min \{ 3.33 ; 5 \text{ MPa} \} = 3.33 \text{ Mpa}$$

$$\tau = 0.43 \leq \bar{\tau}_u = 3.33 \dots \dots \dots \text{C.V}$$

➤ **Verification S.L.S :**

If the following conditions apply, the SLS check will not be necessary:

- The cracking is little harmful.....C.V
- The stress applied is at simple bendingC.V
- The steel used are of a grade of FeE400.....C.V
- The section is rectangular C.V

➤ **Verification of maximum concrete :**

• **On span :**

$$\alpha = 0.081 \leq \frac{\delta-1}{2} + \frac{f_{c28}}{100}$$

$$\delta = \frac{M_u}{M_s} = \frac{46.98}{34.17} = 1.376$$

$$\frac{\delta-1}{2} + \frac{f_{c28}}{100} = \frac{1.376-1}{2} + \frac{25}{100} = 0.438$$

$$0.081 \leq 0.438 \dots \dots \dots \text{C.V}$$

• **On support :**

$$\alpha = 0.028 \leq \frac{\delta-1}{2} + \frac{f_{c28}}{100}$$

$$\delta = \frac{M_u}{M_s} = \frac{16.58}{12.06} = 1.374$$

$$\frac{\delta-1}{2} + \frac{f_{c28}}{100} = \frac{1.374-1}{2} + \frac{25}{100} = 0.437$$

$$0.028 \leq 0.437 \dots\dots\dots \text{C.V}$$

All conditions are checked so there is no verification at SLS.

➤ **Verification of deflection calculation condition:** CBA 93 (art B.6.5.1)

$$\frac{h}{l} \geq \max \left(\frac{1}{16}; \frac{M_t}{10M_0} \right)$$

$$\frac{40}{360} \geq \max \left(\frac{1}{16}; \frac{46.98}{10 \times 55.28} \right)$$

$$0.11 \geq \max (0.0625; 0.085)$$

$$0.11 \geq 0.085 \dots\dots\dots \text{CV}$$

$$\frac{A}{b.d} \leq \frac{4.2}{f_e}$$

$$\frac{4.62}{40 \times 36} = 0.0032 \leq \frac{4.2}{400} = 0.0105 \dots\dots\dots \text{CV}$$

All conditions are checked, so checking the arrow is not necessary.

➤ **Calculation of the landing beam in the torsion :**

The bending moment inside the beam at the landing and bench causes a torsional moment at the landing beam.

$$T_u = \frac{T_{max} \times b}{2} = \frac{61.42 \times 0.4}{2} = 12.3 \text{ KN.m}$$

Calculation of the shear stress:

$$\tau_{uT} = \frac{T_u}{2 \times \Omega \times b_0}$$

With:

T_u : Torsional moment

Ω : Area section

b_0 : Wall thickness

$$b_0 = \frac{b}{6} = 6.67 \text{ cm}$$

$$\Omega = (b - b_0) \times (h - b_0) = 1110.89 \text{ cm}^2$$

$$\tau_{uT} = \frac{12.3 \times 10^{-3}}{2 \times 0.0750 \times 0.05} = 0.83 \text{ MPa}$$

$$\tau_{uT} = 0.83 \text{ MPa} < \tau_u = 3.33 \text{ MPa} \rightarrow \text{C.V}$$

Calculation of torsional balanced reinforcements:

$$A_T = \frac{\mu \times T_u}{2 \times \Omega \times \sigma_s}$$

$$\mu = 2 \times [(b - b_0) + (h - b_0)] = 133.32 \text{ cm}$$

$$A_T = \frac{133.32 \times 12.3 \times 10^{-3} \times 10^{-2}}{2 \times 0.111089 \times 348} = 2.12 \text{ cm}^2 \text{ we take : } 2\text{HA}12 = 2.26 \text{ cm}^2$$

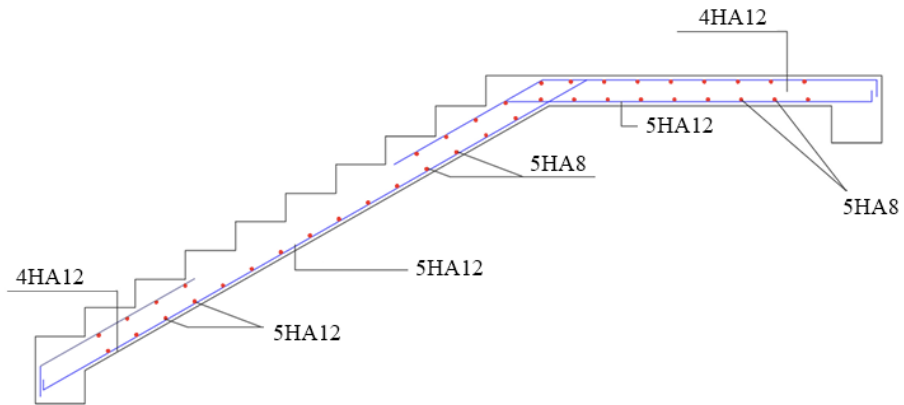

Figure IV.7 Reinforcement of the staircase

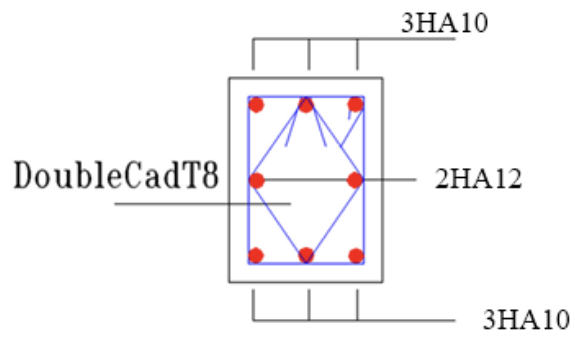

Figure IV.8 Reinforcement of the landing beam

IV.5 Study of Machine slab :

The machine slab, will carry an elevator which is a vertical transportation device typically found in buildings, used to move people or goods between different floors or levels. It consists of a car (or cabin) that moves within a shaft, guided by rails or a track, and is propelled by a system of cables, pulleys, and a motor.

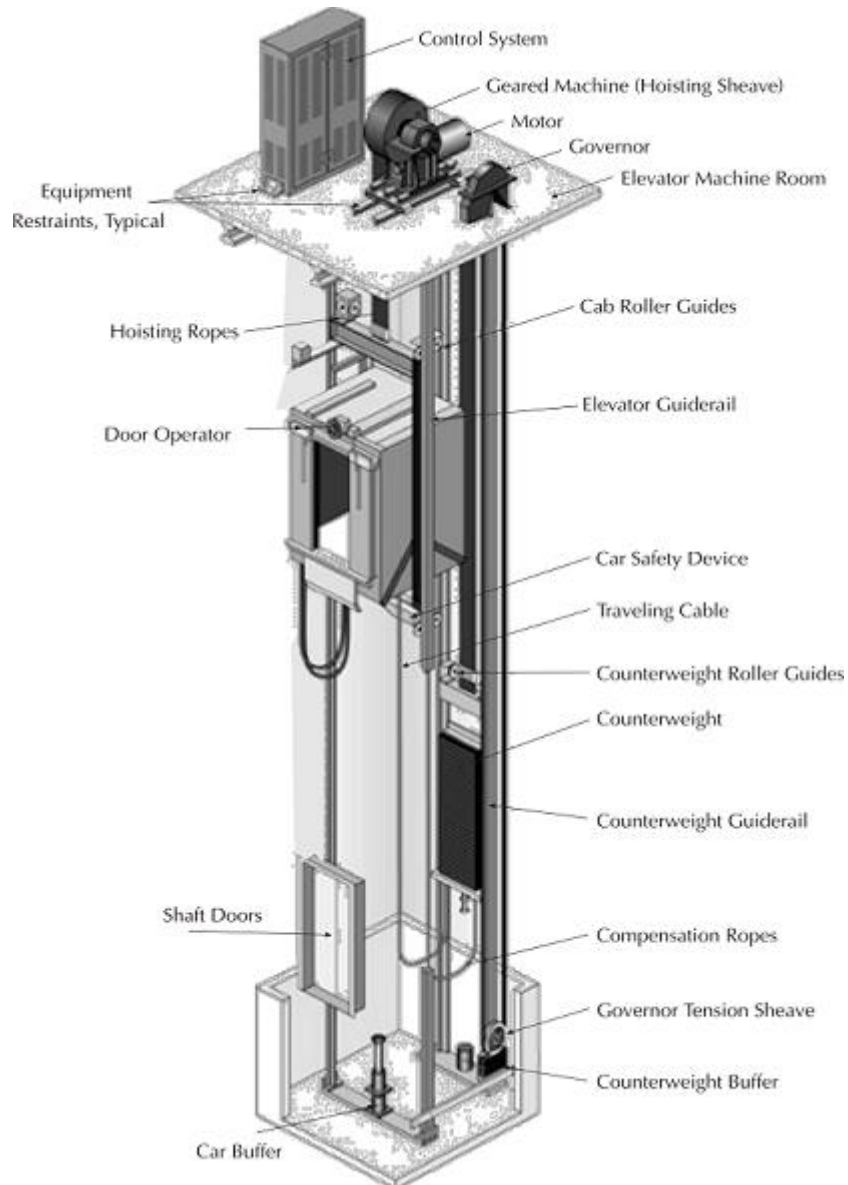

Figure IV.9 Schema of an elevator

IV.5.1 Study of the Elevator :

- The length of the cabin: $l_y = 1.8$ m
- The width of the cabin: $l_x = 1.5$ m
- The depth of the cabin: $h = 2.2$ m
- The thickness of the peripheral wall: $e = 15$ cm
- The total lifting height: $H = 21.42$ m
- The thickness of the machine slab: $e = 0.25$ m
- The estimated lifting speed is: 0.63 m/s

IV.5.1.1 Loads estimate :

In our cabin we have an estimated surface of 2.7 m^2 .

$$Q_{cabin} = 6 \text{ KN (08 people).}$$

$$Q_{terrasse} = 1.5 \text{ KN /m}^2$$

- **Dead load :**

The mass of the empty cabin is 1.3 KN /m^2 so:

$$g_{cabin} = [(2 \times 2.2) + (1.8 \times 2.2) + (1.8 \times 2)] \times 2 = 31.12 \text{ KN}$$

$$g_{cables} = (3 \times 21.42) \times 0.007 = 0.45 \text{ KN}$$

The mass of counterweight is:

$$g_{counterweight} = g_{cabin} + \frac{Q}{2} = 31.12 + \frac{6}{2} = 34.12 \text{ KN}$$

- Motor mass + Winch + accessories $g_{motor} = 12 \text{ KN}$

- **Total mass :**

$$G = \sum g_i = 31.12 + 0.45 + 34.12 + 12 + 6.25 = 84.94 \text{ KN}$$

Estimated thickness check;

$$\frac{L_x}{50} \leq e \leq \frac{L_y}{40} \Rightarrow \frac{1.5}{50} \leq e \leq \frac{1.8}{40} \Rightarrow 0.03 \leq e \leq 0.045$$

The national elevator company (E.N.A) advocates that the thickness of the slab machine is;
 $e \geq 25$ cm

The mass of the machine slab;

$$g_{machine\ slab} = 0.25 \times 25 = 6.25 \text{ KN/m}^2$$

Table IV.5 Load assessment of the machine slab

Materials	Thickness (m)	Volume weight (KN/m ³)	Weight (KN/m ²)
Gravel protection	0.04	17	0.68
Sealing	0.02	6	0.12
Slope shape	0.07	22	1.54
Thermal insulation	0.04	4	0.16
Machine slab	0.25	25	6.65
Plaster	0.02	18	0.36
Permanent load G			9.11

Operating load Q=1.5 KN/m²

IV.5.1.2 Calculation of the moments :

ULS : $q_u = 1,35G + 1,5Q$

$$q_u = (1,35 \times 84,94) + (1,5 \times 6) = 123,67 \text{ KN}$$

SLS: $q_s = G + Q = 90,94 \text{ KN}$

According to the revised BAEL91 99 the load on an impact is;

ULS :

$$q_u^a = \frac{q_u}{4} = \frac{123,67}{4} = 30,92 \text{ KN}$$

SLS :

$$q_s^a = \frac{q_s}{4} = \frac{90,94}{4} = 22,73 \text{ KN}$$

IV.5.1.3 Study of the slab :

- Calculation of the moments under the load of the machines:

Moments caused on the slab by the machine:

$$M_x^m = (M1 + \nu M2) \times q^p$$

$$M_y^m = (\nu M1 + M2) \times q^p$$

According to Pigeaud we will look for the moments:

$$\rho = \frac{Lx}{Ly} = \frac{1,5}{1,8} = 0,8$$

The slab works in two directions:

- **Direction X :**

$$U = U' + ht + k \times hr$$

$$U = 0.15 + 0.25 + 1.5 \times 0.17 = 0.655 \text{ m}$$

- **Direction Y :**

$$V = v' + ht + k \times hr$$

$$V = 0.2 + 0.25 + 1.5 \times 0.17 = 0.705 \text{ m}$$

The surface load:

ULS :

$$q_u^p = \frac{q_u^a}{0.15 \times 0.20} = \frac{30.92}{0.03} = 1030.66 \text{ KN}$$

SLS:

$$q_s^p = \frac{q_s^a}{0.15 \times 0.20} = \frac{22.73}{0.03} = 757.66 \text{ KN}$$

According to Pigeaud's table we find:

$$M1 = 0.0525$$

$$M2 = 0.0358$$

Moments caused on the slab by the machine

ULS :

$$M_x^m = 0.0525 \times 1030.66 = 54.11 \text{ KN.m}$$

$$M_y^m = 0.0358 \times 1030.66 = 36.90 \text{ KN.m}$$

SLS :

$$M_x^m = (0.0525 + 0.2 \times 0.0358) \times 757.66 = 45.20 \text{ KN.m}$$

$$M_y^m = (0.2 \times 0.0525 + 0.0358) \times 757.66 = 35.08 \text{ KN.m}$$

Moments in the slab:

ULS :

$$q_u = 1.35G + 1.5Q$$

$$q_u = 1.35 \times 9.11 + 1.5 \times 1.5 = 14.55 \text{ KN}$$

SLS :

$$q_s = G + Q$$

$$q_s = 9.11 + 1.5 = 10.61 \text{ KN}$$

Stresses calculations :

$$0.4 \leq \rho = \frac{L_x}{L_y} = \frac{1.5}{1.8} = 0.8 \leq 1$$

The slab carries in both directions therefore, the moments are calculated as follows:

$$M_x^d = \mu_x q_u L_x^2$$

$$M_y^d = \mu_y M_x$$

ULS :

$$M_x^d = 0.0565 \times 14.55 \times 1.5^2 = 1.85 \text{ KN.m}$$

$$M_y^d = 0.595 \times 1.85 = 1.1 \text{ KN.m}$$

SLS :

$$M_x^d = 0.0632 \times 10.61 \times 1.5^2 = 1.51 \text{ KN.m}$$

$$M_y^d = 0.710 \times 1.51 = 1.07 \text{ KN.m}$$

μ_x and μ_y taken from the table of plain slabs.

IV.5.1.4 Total moments :

These are the moments due to concentrated loads and the moments due to distributed loads:

ULS :

$$M_x = M_x^d + M_x^m$$

$$M_x = 1.85 + 54.11 = 55.96 \text{ KN.m}$$

$$M_y = M_y^d + M_y^m = 1.1 + 36.90 = 38 \text{ KN.m}$$

SLS :

$$M_x = M_x^d + M_x^m$$

$$M_x = 1.51 + 45.20 = 46.71 \text{ KN.m}$$

$$M_y = M_y^d + M_y^m = 1.07 + 35.08 = 36.15 \text{ KN.m}$$

- **Moments on span :**

ULS :

$$M_x^t = 0.75 \times M_x = 0.75 \times 55.96 = 41.97 \text{ KN.m}$$

$$M_y^t = 0.75 \times M_y = 0.75 \times 38 = 28.5 \text{ KN.m}$$

SLS :

$$M_x^t = 0.75 \times M_x = 0.75 \times 46.71 = 35.03 \text{ KN.m}$$

$$M_y^t = 0.75 \times M_y = 0.75 \times 36.15 = 27.11 \text{ KN.m}$$

- **Moments in support :**

ULS :

$$M_x^a = 0.5 \times M_x = 0.5 \times 55.96 = 27.98 \text{ KN.m}$$

$$M_y^a = 0.5 \times M_y = 0.5 \times 38 = 19 \text{ KN.m}$$

SLS :

$$M_x^a = 0.5 \times M_x = 0.5 \times 46.71 = 23.35 \text{ KN.m}$$

$$M_y^a = 0.5 \times M_y = 0.5 \times 36.15 = 18.07 \text{ KN.m}$$

IV.5.2 Calculation of reinforcement direction X-X :

- **On span :**

$$\mu = \frac{M_u}{b \cdot d^2 \cdot f_{bu}}$$

$$\mu_u = \frac{41.97 \times 10^{-3}}{1 \times 0.135^2 \times 14.2} = 0.162 \leq \mu_L = 0.392 \quad (A'_s = 0)$$

$$\mu = 0,162 < \mu = 0,186 \Rightarrow \text{pivot (A)}$$

$$\alpha = 1.25 \times (1 - \sqrt{1 - 2 \times 0.162}) = 0.222$$

$$\beta = (1 - 0.4\alpha) \rightarrow \beta = 0.9112$$

$$A_s = \frac{41.97 \times 10^3}{0.9112 \times 13.5 \times 348} = 9.8 \text{ cm}^2$$

- **In support :**

$$\mu = \frac{M_u}{b \cdot d^2 \cdot f_{bu}}$$

$$\mu_u = \frac{27.98 \times 10^{-3}}{1 \times 0.135^2 \times 14.2} = 0.108 \leq \mu_L = 0.392 \quad (A'_s = 0)$$

$$\mu = 0,108 < \mu = 0,186 \Rightarrow \text{pivot (A)}$$

$$\alpha = 1.25 \times (1 - \sqrt{1 - 2 \times 0.108}) = 0.143$$

$$\beta = (1 - 0.4\alpha) \rightarrow \beta = 0.9428$$

$$A_s = \frac{27.98 \times 10^3}{0.9428 \times 13.5 \times 348} = 6.32 \text{ cm}^2$$

- **Non-fragile condition X-X :**

$$A_{x s \min} = \frac{3 - \rho}{2} = \frac{3 - 0.8}{2} = 1.1 \text{ cm}^2$$

- **Longitudinal reinforcement X-X :**

Span :

$$A_s^t = \text{Max} (A_s; A_{x s \min}) = 9.8 \text{ cm}^2$$

$$\text{We take } 5T16 = 10.05 \text{ cm}^2$$

$$\text{Spacing: } e = 20 \text{ cm}$$

Support :

$$A_s^a = \text{Max} (A_s; A_{x s \min}) = 6.32 \text{ cm}^2$$

We take $5T14 = 7.69 \text{ cm}^2$

Spacing: $e = 20 \text{ cm}$

IV.5.3 Calculation of reinforcement direction Y-Y :

- **On span :**

$$\mu = \frac{M_u}{b \cdot d^2 \cdot f_{bu}}$$

$$\mu_u = \frac{28.5 \times 10^{-3}}{1 \times 0.135^2 \times 14.2} = 0.11 \leq \mu_L = 0.392 (A'_s = 0)$$

$\mu = 0,11 < \mu = 0,186 \Rightarrow$ pivot (A)

$$\alpha = 1.25 \times (1 - \sqrt{1 - 2 \times 0.11}) = 0.146$$

$$\beta = (1 - 0.4\alpha) \rightarrow \beta = 0.9416$$

$$A_s = \frac{28.5 \times 10^3}{0.9416 \times 13.5 \times 348} = 6.44 \text{ cm}^2$$

- **In support :**

$$\mu = \frac{M_u}{b \cdot d^2 \cdot f_{bu}}$$

$$\mu_u = \frac{19 \times 10^{-3}}{1 \times 0.135^2 \times 14.2} = 0.073 \leq \mu_L = 0.392 (A'_s = 0)$$

$\mu = 0,073 < \mu = 0,186 \Rightarrow$ pivot (A)

$$\alpha = 1.25 \times (1 - \sqrt{1 - 2 \times 0.073}) = 0.095$$

$$\beta = (1 - 0.4\alpha) \rightarrow \beta = 0.962$$

$$A_s = \frac{19 \times 10^3}{0.962 \times 13.5 \times 348} = 4.02 \text{ cm}^2$$

- **Non-fragile condition Y-Y :**

$$A_{x s \min} = \rho \times b \times h = 0.0008 \times 100 \times 25 = 2 \text{ cm}^2$$

- **Longitudinal reinforcement Y-Y :**

Span :

$$A_s^t = \text{Max} (A_s; A_{x s \min}) = 6.44 \text{ cm}^2$$

We take $5T14 = 7.69 \text{ cm}^2$

Spacing: $e = 20 \text{ cm}$

Support :

$$A_s^a = \text{Max} (A_s; A_{x s \min}) = 4.02 \text{ cm}^2$$

We take $5T12 = 5.65 \text{ cm}^2$

Spacing: $e = 20 \text{ cm}$

Checking the shear force :

$$T_x = \frac{q_u \times L_x \times L_y}{2 \times L_x + L_y} = \frac{123.67 \times 1.5 \times 1.8}{2 \times 1.5 + 1.8} = 69.56 \text{ KN}$$

$$T_y = \frac{q_u \times L_x}{3} = \frac{123.67 \times 1.5}{3} = 61.83 \text{ KN}$$

According to CBA93:

$$\bar{\tau}_u = 0.07 \times \frac{f_{c28}}{\gamma_b} = 0.07 \times \frac{25}{1.5} = 1.16 \text{ MPa}$$

$$\tau = \frac{T_{max}}{b.d} = \frac{69.56 \times 10^{-3}}{1 \times 0.135} = 0.515 \text{ MPa} \leq \bar{\tau}_u = 1.16 \text{ MPa} \dots\dots\dots \text{CV}$$

So, the transverse reinforcements are not required.

IV.5.4 Verification S.L.S :

If the following conditions apply, the SLS check will not be necessary:

- The cracking is little harmful.....C.V
- The stress applied is at simple bendingC.V
- The steel used are of a grade of FeE400.....C.V
- The section is rectangular C.V

➤ **Verification of maximum concrete :**

• **On span X-X :**

$$\alpha = 0.222 \leq \frac{\delta-1}{2} + \frac{f_{c28}}{100}$$

$$\delta = \frac{M_u}{M_s} = \frac{41.97}{35.03} = 1.2$$

$$\frac{\delta-1}{2} + \frac{f_{c28}}{100} = \frac{1.2-1}{2} + \frac{25}{100} = 0.35$$

0.222 ≤ 0.35C.V

• **On support X-X :**

$$\alpha = 0.143 \leq \frac{\delta-1}{2} + \frac{f_{c28}}{100}$$

$$\delta = \frac{M_u}{M_s} = \frac{27.98}{23.35} = 1.2$$

$$\frac{\delta-1}{2} + \frac{f_{c28}}{100} = \frac{1.2-1}{2} + \frac{25}{100} = 0.35$$

0.143 ≤ 0.35C.V

All conditions are checked so there is no verification at SLS.

• **On span Y-Y :**

$$\alpha = 0.146 \leq \frac{\delta-1}{2} + \frac{f_{c28}}{100}$$

$$\delta = \frac{M_u}{M_s} = \frac{28.5}{27.11} = 1.05$$

$$\frac{\delta-1}{2} + \frac{f_{c28}}{100} = \frac{1.05-1}{2} + \frac{25}{100} = 0.275$$

0.146 ≤ 0.275C.V

• **On support Y-Y :**

$$\alpha = 0.095 \leq \frac{\delta - 1}{2} + \frac{f_{c28}}{100}$$

$$\delta = \frac{M_u}{M_s} = \frac{19}{18.07} = 1.05$$

$$\frac{\delta - 1}{2} + \frac{f_{c28}}{100} = \frac{1.05 - 1}{2} + \frac{25}{100} = 0.275$$

$$0.095 \leq 0.275 \dots\dots\dots \text{C.V}$$

All conditions are checked so there is no verification at SLS

• **Verification of deflection calculation condition: CBA 93 (art B.6.5.1)**

X-X direction :

$$\frac{h}{l} \geq \max \left(\frac{1}{16}; \frac{M_t}{10M_0} \right)$$

$$\frac{0.25}{1.5} \geq \max \left(\frac{1}{16}; \frac{41.97}{10 \times 55.96} \right) \rightarrow 0.166 \geq 0.075 \dots\dots\dots \text{CV}$$

$$\frac{A}{b \times d} \leq \frac{4.2}{f_e}$$

$$\frac{10.05}{100 \times 13.5} = 0.007 \leq \frac{4.2}{400} = 0.0105 \dots\dots\dots \text{CV}$$

Y-Y direction :

$$\frac{h}{l} \geq \max \left(\frac{1}{16}; \frac{M_t}{10M_0} \right)$$

$$\frac{0.25}{1.8} \geq \max \left(\frac{1}{16}; \frac{28.5}{10 \times 38} \right) \rightarrow 0.138 \geq 0.075 \dots\dots\dots \text{CV}$$

$$\frac{A}{b \times d} \leq \frac{4.2}{f_e}$$

$$\frac{7.69}{100 \times 13.5} = 0.0057 \leq \frac{4.2}{400} = 0.0105 \dots\dots\dots \text{CV}$$

So, checking the arrow is not necessary.

IV.6 Study of balconies :

The balcony is a solid slab considered embedded in the beams, it is calculated as a console and scrap in simple bending. The balcony is subject to a permanent load G (weight own), and an operating charge Q

IV.6.1 Load assessment :

$$\left\{ \begin{array}{l} G = 5.27 \times 1 = 5.27 \frac{\text{KN}}{\text{ml}} \\ Q = 3.50 \times 1 = 3.50 \frac{\text{KN}}{\text{ml}} \end{array} \right.$$

- Wall on balcony: G = 1.54 KN/m²

$$P = 1.54 \times 1.20 = 1.85 \text{ KN/ml}$$

IV.6.2 Load combinations :• **ULS :**

$$q_u = 1.35 G + 1.5 Q$$

$$P_u = 1.35 \times P$$

$$q_u = (1.35 G + 1.5 Q) \times 1\text{m} = (1.35 \times 5.27 + 1.5 \times 3.5) \times 1\text{m} = 12.36 \text{ KN/ml}$$

$$P_u = 1.35 P \times 1\text{m} = 1.35 \times 1.85 = 2.50 \text{ KN}$$

• **SLS :**

$$q_s = G + Q$$

$$P_s = P$$

$$q_s = (G + Q) \times 1\text{m} = (5.27 + 3.5) \times 1\text{m} = 8.77 \text{ kN/ml}$$

$$P_s = P \times 1\text{m} = 1.85 \times 1\text{m} = 1.85 \text{ KN}$$

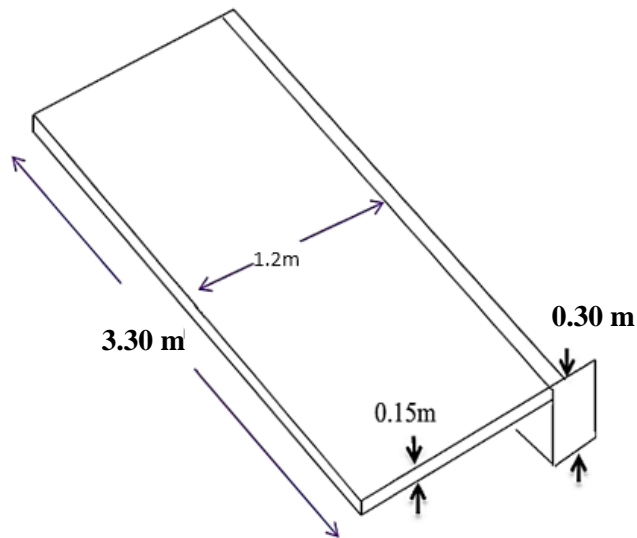

Figure IV.10 Dimensions of the balcony

IV.6.3 Embedding moment:• **ULS :**

$$M_u = P_u \times L + \frac{q_u l^2}{2} = 2.50 \times 1.2 + \frac{12.36 \times 1.2^2}{2} = 11.9 \text{ KN.m}$$

• **SLS :**

$$M_s = P_s \times L + \frac{q_s l^2}{2} = 1.85 \times 1.2 + \frac{8.77 \times 1.2^2}{2} = 8.53 \text{ KN.m}$$

IV.6.4 Calculation of reinforcement :

The calculation is done in simple bending at the ULS, for a strip of 1ml

$$d = 0.9h = 0.9 \times 15 = 13.5 \text{ cm}$$

$$M_u = 11.9 \text{ KN.m}$$

$$\mu_u = \frac{M_u}{b \cdot d^2 \cdot f_{bu}} = \frac{11.9 \times 10^3}{100 \times 13.5^2 \times 14.2} = 0.046$$

$$\mu = 0.046 < \mu_l = 0.391 \dots\dots A' = 0 \text{ no compressed reinforcement}$$

$$\alpha = 1.25 \times (1 - \sqrt{1 - 2\mu}) = 1.25 \times (1 - \sqrt{1 - 2 \times 0.046}) = 0.058$$

$$\beta = (1 - 0.4\alpha) = (1 - 0.4 \times 0.058) = 0.9768$$

$$\rightarrow \beta = 0.9768$$

$$A_s = \frac{0.8\alpha \times b \times d \times f_{bc}}{\sigma_s} = \frac{0.8 \times 0.058 \times 100 \times 13.5 \times 14.2}{348} = 2.556 \text{ cm}^2$$

➤ **Non-fragile condition :**

$$A_{s \min} = \frac{0.23 \times b \times d \times f_{t28}}{f_e} = 1.630 \text{ cm}^2 \leq 2.56 \text{ cm}^2 \dots\dots\dots CV$$

$$A = \text{Max}(A_u, A_{\min}) = \text{Max}(2.56 ; 1.63) = 2.56 \text{ cm}^2$$

With that we adopt: **4HA12 = 4.52 cm²**

➤ **Distribution reinforcement :**

$$A_{dist} = \frac{A}{4}$$

$$A_{dist} = \frac{4.52}{4} = 1.13 \text{ cm}^2$$

So, we adopt: **2HA12 = 2.26 cm²**

IV.6.5 Verification S.L.S : (CBA93)

The calculation is made according to the rules of C.B.A 93 and B.A.E.L 91, the cracking is considered detrimental.

- **Calculation of the position of the neutral axis :**

A' = 0 no compressed reinforcement

$$b \times y^2 + 30 \times A_s \times y - 30 \times d \times A_s = 0$$

$$100 \times y^2 + 30 \times 4.52 \times y - 30 \times 13.5 \times 4.52 = 0$$

$$100y^2 + 135.6y - 1830.6 = 0$$

The solution will be done as follows:

$$\Delta = b^2 - 4 \times a \times c$$

$$\Delta = 135.6^2 - 4 \times 100 \times 1830.6$$

$\Delta > 0$ so the equation admits two solutions:

$$\begin{cases} y_1 = 3.65 \\ y_2 = -5.01 \end{cases}$$

We take $y = 3.65$ cm

- Calculate the moment of inertia :

$$I = \frac{b \times y^3}{3} + \eta [A_s \times (d - y)^2 + A' \times (y - d')^2]$$

$$I = \frac{1 \times 0.0365^3}{3} + 15 [4.52 \times 10^{-4} (0.135 - 0.0365)^2] = 8.2 \times 10^{-5} m^4$$

- Checking of stresses :

Stresses in concrete: $\bar{\sigma}_{bc} = 0,6 \times f_{c28} = 15$ MPa

$$\sigma_{bc} = \frac{M_{ser}}{I} \times y = \frac{8.5310^{-3}}{8.2 \times 10^{-5}} \times 0.0365 = 3.80 < \bar{\sigma}_{bc} \dots\dots CV$$

Stresses in steel: $\bar{\sigma}_{st} = \min \left[\frac{2}{3} f_e, \max (0,5 \times f_e ; 110 \sqrt{\eta f_{tj}}) \right] = 201.63$ MPa

$$\sigma_{st} = \eta \frac{M_{ser}}{I} (d - y) = 15 \times \frac{8.5310^{-3}}{8.2 \times 10^{-5}} \times (0.135 - 0.0365) = 153.70 \text{ MPa} < \bar{\sigma}_{st} \dots CV$$

- Checking the shear force :

$$\bar{\tau}_u = \min \left\{ \frac{0.15 \times f_{c28}}{\gamma_b} ; 4 \text{ MPa} \right\} = 2.5 \text{ MPa}$$

The tangent stress: $\tau = \frac{T_u}{b.d}$

$$T_u = q.L + P = 12.36 \times 1.2 + 2.50$$

$$T_u = 17.332 \text{ KN}$$

$$\tau = \frac{T_u}{b.d} = \frac{17.332 \times 10^{-3}}{1 \times 0.135} = 0.13 \text{ MPa} \leq \bar{\tau}_u = 2.5 \dots\dots C.V$$

So transverse reinforcements are not necessary.

- Verification of deflection calculation condition : CBA 93 (art B.6.5.1)

$$\frac{h}{l} \geq \max \left(\frac{1}{16} ; \frac{M_t}{10 M_0} \right)$$

$$\frac{0.15}{1.20} \geq \max \left(\frac{1}{16} ; \frac{11.9}{10 \times 11.9} \right) \rightarrow 0.125 \geq 0.1 \dots\dots\dots CV$$

$$\frac{A}{b \times d} \leq \frac{4.2}{f_e}$$

$$\frac{4.52}{100 \times 13.5} = 0.003 \leq \frac{4.2}{400} = 0.0105 \dots\dots\dots CV$$

All conditions are checked, so checking the arrow is not necessary.

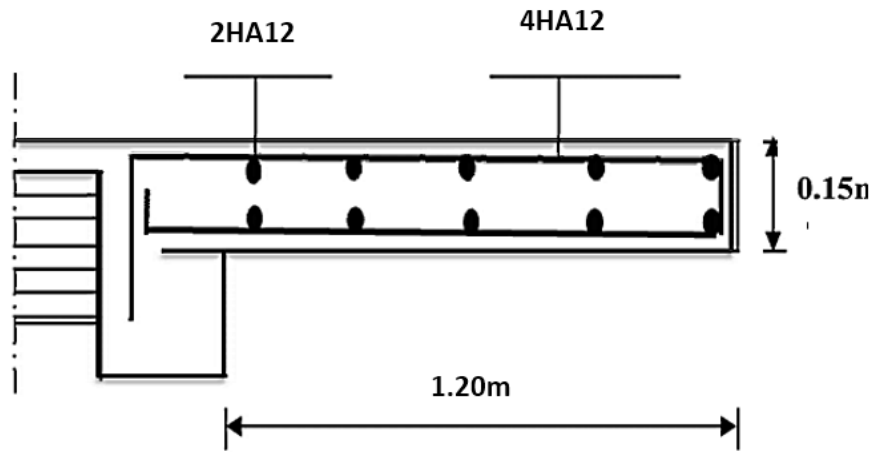

Figure IV.11 Reinforcement of the balcony

Chapter

V

Chapter V

Dynamic analysis:

V.1. Introduction :

An earthquake, is a geological phenomenon characterized by the sudden and violent tremor of the soil, usually caused by the movement of the tectonic plates of the Earth’s crust. This movement releases a large amount of energy in the form of seismic waves that propagate through the earth. Earthquakes can vary in intensity, ranging from minor tremors to major events that can cause significant damage to buildings, infrastructure and people.

The seismic analysis enables us to determine the least favorable characteristic parameters of the seismic response and the design of the structural components, aiming to achieve a satisfactory level of safety for the entire structure and ensure the well-being of the occupants.

In order to validate our recommendations about the pre-dimensioning of the elements (Chapter II),

we will proceed to do the seismic investigation of the structure using a well-defined calculation approach in the RPA.

V.2 Calculation methods :

The dynamic analysis will be by those methods submitted from the Algerian seismic standards RPA99 V 2003.

- The static equivalent method.
- The response spectrum method.
- The time history method.

V.3 Modulization :

ETABS (Extended Three-dimensional Analysis of Building Systems) is a software package used for the structural analysis and design of buildings. It's particularly popular in the field of civil engineering and structural design. ETABS allows engineers to model and analyse building structures, considering various factors such as loads, materials, and design codes.

So, we will model the structure in this programme.

This model should accurately mirror the behaviour and parameters of the original system.

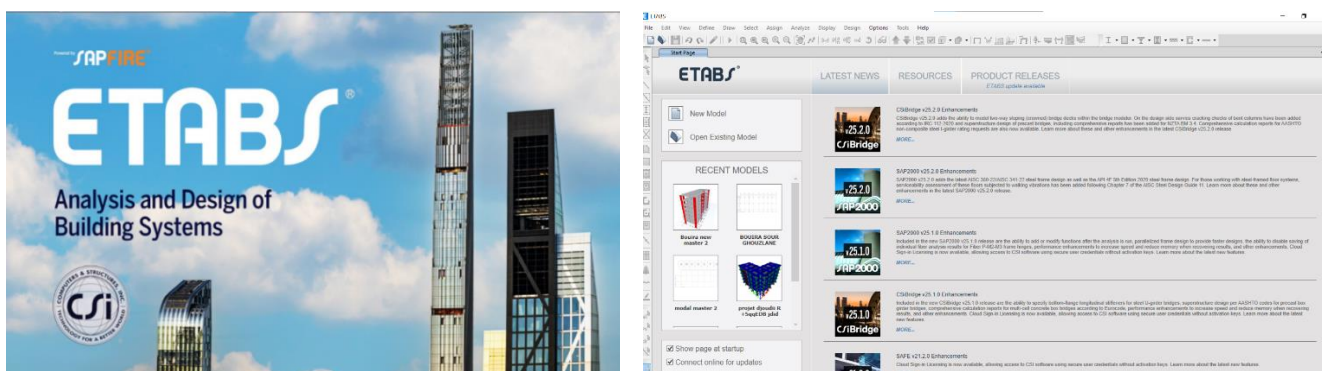

Figure V.1 Programme of modulization

V.3.1 Modeling approach on the ETABS software :

- ❖ **New Model:** definition of a new model.

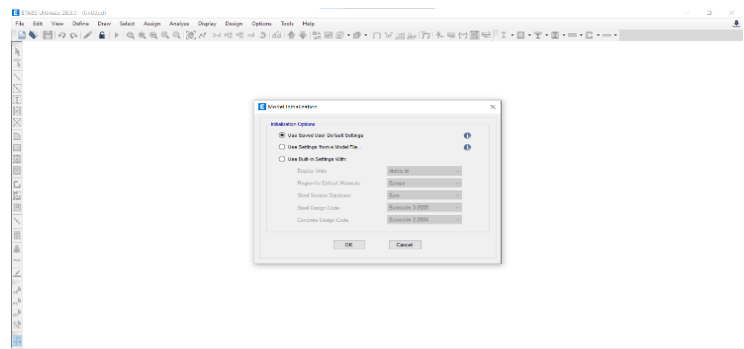

Figure V.2 Defining a new model

- ❖ **Grid definition and story levels:**

Definition of the horizontal grid (Custom grid spacing then Story dimensions) and specification of the number and height of the floors

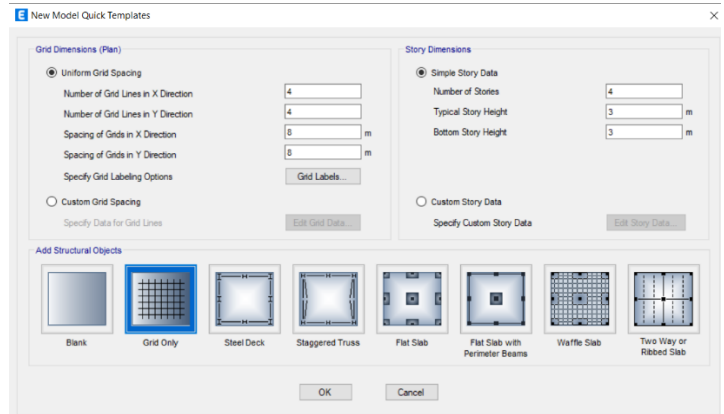
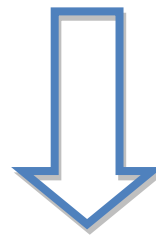

Figure V.3 Set up grid lines and define story levels



There here we can edit the stories dimensions in both directions

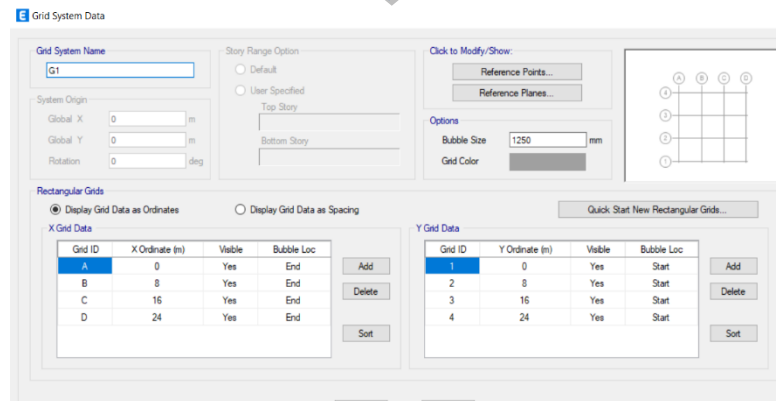

Figure V.4 Editing the grid

❖ Define materials :

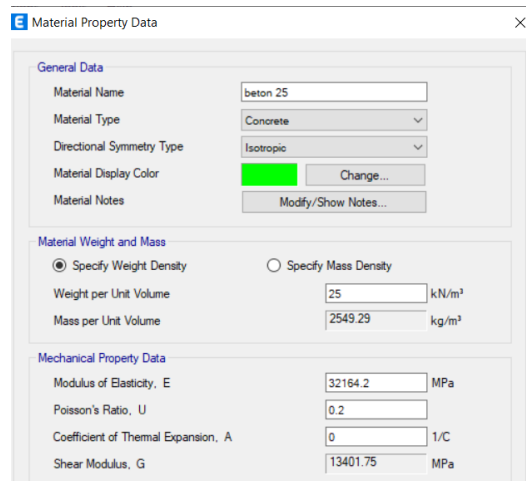
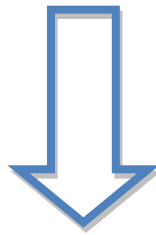
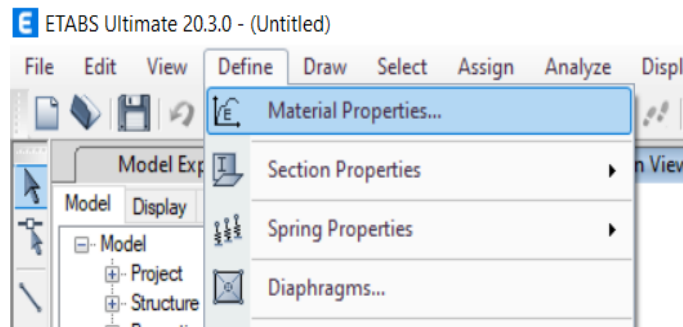

Figure V.5 Define materials

❖ Define the sections (Column, beams...) :

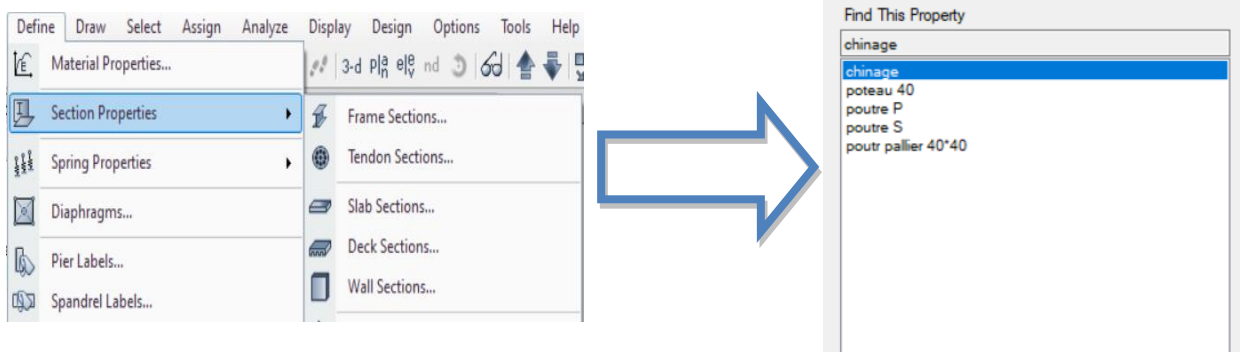

Figure V.6 Define the sections

❖ Definition of loads and load cases :

In this step we give a name for each type of load and its designation.

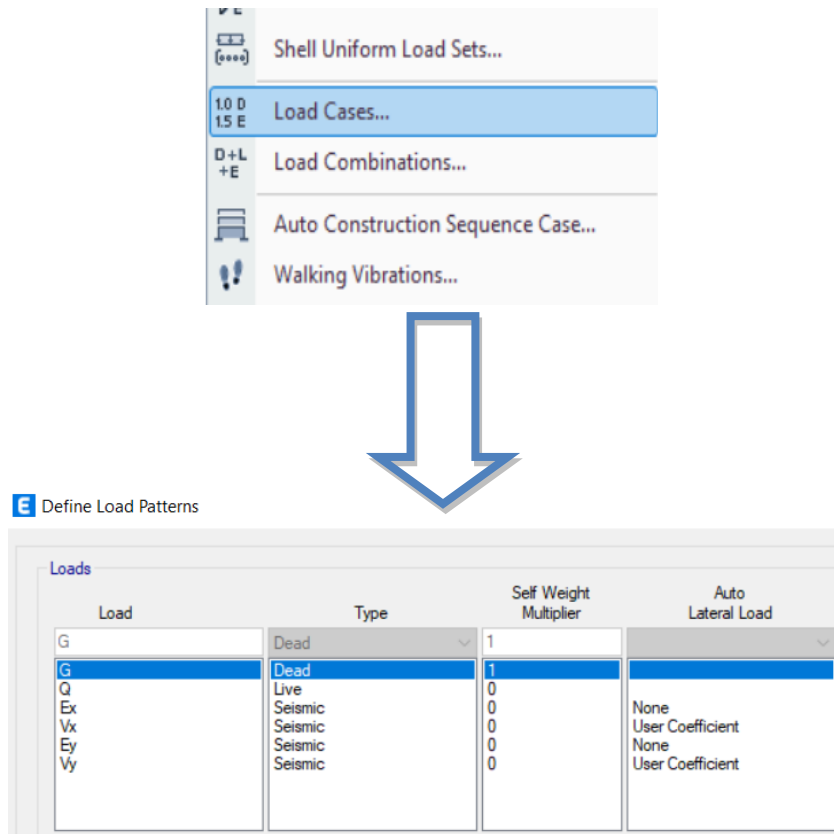

Figure V. 7 Definition of loads

❖ Load combinations: Following the definition of the different combinations proposed by the regulations in force with the option «Load Combinations»

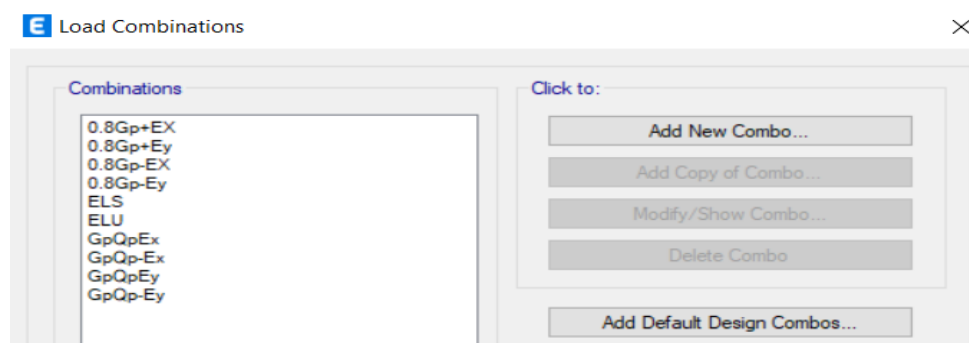

Figure V. 8 Definition of the different combinations

The combinations of actions to be considered for the determination of stresses and calculation deformations are:

- $SLS = G + Q$
- $ULS = 1.35 G + 1.5 Q$
- $G + Q + E$

- 0.8 G + E
- 0.8 G – E

❖ **Diaphragms :**

To consider the hypothesis of rigid floors in their plans, it is necessary to define a diaphragm grouping all the nodes of the same floor and this for all levels.

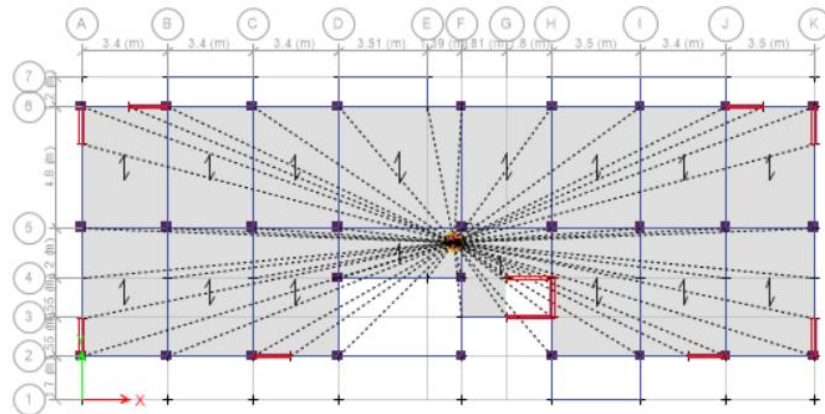

Figure V.9 Definitions of diaphragms

We first review the model to confirm our structure before modelling the masses and loads, specifying load combinations, and beginning the analysis.

The adopted model is recessed at the base, it comprises only the elements (columns, beams, floor, and sails), the rest of the elements is introduced as a load.

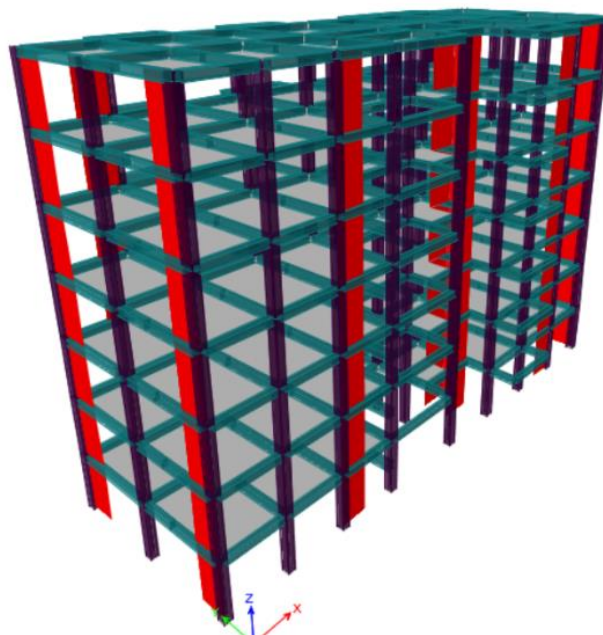

Figure V.10 Structure modulization

V.4 Classification criteria by RPA99V2003 :

RPA Classification Criteria 99 Version 2003 it is set of classifications necessary for the definition of the seismic situation studied and the choice of method and parameters for calculating seismic forces.

V.4.1 Classification of seismic zones : (RPA99V2003 art 3.1)

According to the Algerian regulation on earthquakes, there are 4 zones with variable earthquakes on the map of seismic zones and their timing, which determines this distribution by State and municipalities, namely:

- **Zone 0** : Negligible seismicity
- **Zone I** : Low seismicity
- **Zone IIa and IIb**: Medium seismicity
- **Zone III**: High seismicity

Our building is located in the wilaya of BOUIRA so in **zone IIa (Medium seismicity)**.

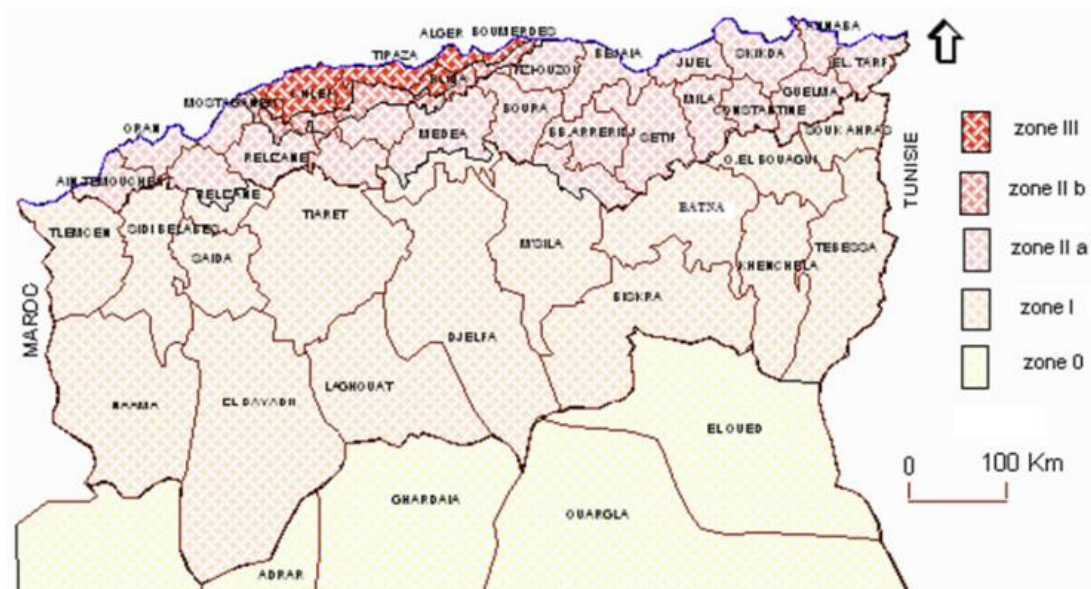

Figure V.11 Classification of seismic zones

V.4.2 Classification of structures according to their importance : (RPA99V2003 art 3.2)

The minimum level of seismic protection granted to a structure depends on its intended purpose and importance in relation to the protection objectives set by the community.

According to RPA99/2003 the Structures are classified into four groups:

- **Group 1A:** Vital structures.
- **Group 1B:** Structures of great importance.

- **Group 2:** Current or medium-sized structures.
- **Group 3:** Minor Structures

Our building is classified in Group 1A (Works of vital importance).

V.4.3 Site classification : (RPAV2003 art 3.3)

The sites are classified into four (04) categories according to the mechanical properties of the soils that are:

- **Category S1:** rocky site.
- **Category S2:** closed site.
- **Category S3:** furniture site.
- **Category S4:** very furniture site.

According to the geotechnical ratio on our building, we are in category S2 (closed site).

V.4.4 Classification of bracing systems : (RPA99V2003 art 3.4)

The purpose of the classification of structural systems is reflected in the rules and methods of calculation, by assigning for each of the categories of this classification, a numerical value of the coefficient of behaviour **R** this coefficient is given according to the (table 4.3 RPAV2003).

In our case, the structure is mixed supported by walls and porticoes with reinforced concrete
So: **R=5**

V.5 Static equivalent method : (RPA99V2003 art 4.2)

A fictional static force system is used to substitute the real dynamic forces that arise in the structure, and its effects are compared to those of seismic activity.

The ground can move in any direction in the horizontal plane.

The equivalent horizontal seismic forces shall be considered to be applied successively in two orthogonal directions selected by the projector. In the general case, these two directions are the main axes of the horizontal plane of the structure.

The equivalent static method may be used under the following conditions:

- The building studied, meets the conditions of regularity in plan and elevation with a height not exceeding 65 m in zones (I and IIa) and 30 m in zones (IIb and III).

In this study, our building is located in zone IIa and height $h = 21.42 \text{ m} < 65 \text{ m}$ CV

➤ **Regularity in plan : (RPA99V2003 art 3.5.1.a)**

Every building needs to be categorized based on whether it is a typical building or not, based on its plan configuration and elevation:

a1- The building must have a substantially symmetrical configuration with respect to two orthogonal directions for both the distribution of stiffness and that of masses:

Because of the distancing of the periods (mode 1 = 0.701s, mode 2 = 0.54 s), we can say that this condition is not satisfied

a2- At each level and for each direction of calculation, the distance between the centre of gravity

of the masses and the centre of stiffness does not exceed 15% of the size of the building measured perpendicular to the direction of the seismic action considered:

Table V.1 Centers of mass and rigidity

TABLE: Centers Of Mass and Rigidity										
Story	XCM	YCM	XCR	YCR	ex	ey	15%LY	15%LX	Verification	
	m	m	m	m	m	m	m	m	x	y
Story7	14.5166	6.8137	14.5634	7.2795	0.0468	0.4658	1.905	4.425	CV	CV
Story6	8.8306	8.0662	12.4815	7.204	3.6509	0.8622	1.905	4.425	CV	CV
Story5	8.8306	8.0662	9.848	7.1724	1.0174	0.8938	1.905	4.425	CV	CV
Story4	8.8306	8.0662	7.8094	7.1402	1.0212	0.926	1.905	4.425	CV	CV
Story3	8.8306	8.0662	6.6087	7.1229	2.2219	0.9433	1.905	4.425	CV	CV
Story2	8.8306	8.0662	6.7599	7.0528	2.0707	1.0134	1.905	4.425	CV	CV
Story1	14.5576	6.8998	14.063	6.0758	0.4946	0.824	1.905	4.425	CV	CV

This standard meets all conditions in both directions

a3- The shape of the building must be compact with a length/width ratio of the floor less than

or equal 4:

$$\frac{\text{length}}{\text{width}} = \frac{29.5}{12.7} = 2.32 \leq 4 \dots\dots\dots\text{C. V}$$

The sum of the dimensions of the re-entrant or projecting parts of the building in one direction data must not exceed 25% of the total size of the building in this direction:

$$\frac{l_y}{L_y} \leq 0.25 \Rightarrow \frac{1.2+1.7}{12.7} = 0.23 \leq 0.25 \dots\dots\dots\text{C.V}$$

So, the building classified non-regular in plan.

➤ **Regularity in elevation : (RPA99V2003 art 3.5.1.b)**

b1- The bracing system must not have a discontinuous vertical load-bearing element, whose charge is not transferred directly to the foundation.

b2- Both the stiffness and the mass of the different levels remain constant or decrease gradually and without sudden loading from the base to the top of the building.

b3. The mass-to-stiffness ratio of two successive levels shall not vary by more than 25% in each calculation direction. The variation in mass and stiffness from one floor to another are negligible.

b4- In the case of elevation stalls, the variation in the dimensions in the plan of the building between two successive levels does not exceed 20% in both directions of calculation and does not is carried out only in the direction of a decrease with height. The largest lateral dimension of the building does not exceed 1.5 times its smallest dimension.

→ No elevation stalls in both directions.

All the criteria of regularity in elevation (b1 to b 4) are respected, so the structure is classified regular in elevation.

- So, the equivalent static method is not applicable, we must calculate the force total seismic applied to the base of the structure by the equivalent static method for compared with that given by the dynamic method.

V.5.1 Calculation of seismic force : (RPA99V2003 art 4.2.3)

With this method, the effective seismic intensity is reported as times the maximum shear force at the base of the structure.

$$V = \frac{A \times D \times Q}{R} \times W$$

A: Acceleration coefficient of the zone.

D: Average dynamic amplification bill.

Q: quality factor.

R: coefficient of overall behavior of the structure.

W: Total weight of the structure.

➤ **Acceleration coefficient of the zone (A):**

The acceleration coefficient in zone IIa is given by Table (4.1) of RPA99/Version 2003

depending on the seismic zone and the building's use group.

Table V.2 Acceleration coefficient of the zone (A)

Zone Group	I	II	III
1A	0.12	0.25	0.35
1B	0.10	0.20	0.30
2	0.08	0.15	0.25
3	0.05	0.10	0.15

For a use group A1 in zone IIa we have: $A = 0.25$

➤ **Average dynamic amplification bill (D) :**

Depends on site category, depreciation correction factor (η) period fundamental of the structure(T):

$$D = \begin{cases} 2.5 \eta & \text{if } 0 \leq T \leq T_2 \\ 2.5 \eta \left(\frac{T_2}{T}\right)^{\frac{2}{3}} & \text{if } T_2 \leq T \leq 3 \text{ s} \\ 2.5 \eta \left(\frac{T_2}{3}\right)^{\frac{2}{3}} \left(\frac{3}{T}\right)^{\frac{5}{3}} & \text{if } T > 3 \text{ s} \end{cases}$$

η : The damping correction factor: given by the formula:

$$\eta = \sqrt{\frac{7}{(2+\xi)}} \geq 0.7$$

ξ : Percentage of critical depreciation that depends on several parameters, taken from the table 4.2 of the RPA99V2003:

Table V.3 Value of ξ

Filling	Gantry		Sails or walls
	reinforced concrete	Steel	reinforced concrete/ masonry
Light	6	4	10
Dense	7	5	

We have the structure is mixed supported by walls and porticoes with reinforced concrete

so: $\xi = 10 \%$

$$\text{So: } \eta = \sqrt{\frac{7}{(2+10)}} = 0.764 \geq 0.7$$

$$\text{So: } \eta = 0.764$$

T_2 : Characteristic period, associated with the site category and given by the table [4.7] of RPA99/Version 2003.

Table V.4 value of T_1 and T_2

Site	S1	S2	S3	S4
T_1 (s)	0.15	0.15	0.15	0.15
T_2 (s)	0.30	0.40	0.50	0.70

We have for site 2 $\rightarrow T_2 = 0.40$ s

T: the fundamental period of the structure: According to the RPA99/V2003 art 4.2.4

➤ **Formula 1 :**

$$T = C_T h_N^{\frac{3}{4}}$$

h_N : Height measured in meters from the base of the structure to the last level:

$$h_N = 21.42 \text{ m}$$

C_T : Coefficient, function of bracing system,

Our structure is braced by reinforced concrete walls (Case 4), so: $C_T = 0.050$

$$\text{So, } T = T_{x-x} = T_{y-y} = 0.05 \times 21.42^{\frac{3}{4}} = 0.4978 \text{ s}$$

➤ **Formula 2:**

$$T_{x,y} = 0.09 \times \frac{h_N}{\sqrt{D_{x,y}}}$$

$D_{x,y}$: Dimension of the building in the direction considered (x and y)

$$T_s = \min \left(T = C_T h_N^{\frac{3}{4}} ; T_{x,y} = 0.09 \times \frac{h_N}{\sqrt{D_{x,y}}} \right)$$

- **Direction x-x**

$$T_x = 0.09 \times \frac{21.42}{\sqrt{12.7}} \Rightarrow T_x = 0.541 \text{ s}$$

- **Direction y-y**

$$T_y = 0.09 \times \frac{21.42}{\sqrt{29.5}} \Rightarrow T_y = 0.355 \text{ s}$$

So:

$$T_{x-emp} = \min (T ; T_x) = \min (0.4978 s , 0.541 s)$$

$$T_{x-emp} = \mathbf{0.4978 s}$$

$$T_{y-emp} = \min (T , T_y) = \min (0.4978 s , 0.355s)$$

$$T_{y-emp} = \mathbf{0.355 s}$$

We note that: $T_2 = 0.4 s \leq T_{x-x} = 0.4978 \leq 3s$ so we have:

$$D_x = 2.5 \eta \left(\frac{T_2}{T} \right)^{\frac{2}{3}} = 2.5 \times 0.764 \left(\frac{0.4}{0.4978} \right)^{\frac{2}{3}} = 1.65$$

$$\rightarrow D_x = \mathbf{1.65}$$

$$\text{And: } 0 \leq T_{y-y} = 0.355s \leq T_2 = 0.40 s$$

so, we have:

$$D_y = 2.5 \eta = 2.5 \times 0.764 = 1.91$$

$$\rightarrow D_y = \mathbf{1.91}$$

➤ **Quality factor (Q)**

According to the RPA99/V2003 page (42) the value of Q is determined by the formula:

$$Q = 1 + \sum P_q$$

P_q : is the penalty to be taken according to whether the quality criterion "q" is met or not.

Its value is given according to the RPA in Table [4.4]

Table V.5 Value of P_q for the direction x-x

Quantity criterion q	P_q		
	Observed	Not observed	Value
1- Minimum condition on queues bracing	x		0
2- Redundancy in plan	x		0
3- Regularity in plan		x	0.05
4- Regularity in elevation	x		0
5- Quality control of materials		x	0.05
6- Quality control of execution		x	0.1

Table V.6 Value of P_q for the direction y-y

Quantity criterion q	P_q		
	Observed	Not observed	Value
1- Minimum condition on queues bracing	x		0
2- Redundancy in plan	x		0
3- Regularity in plan		x	0.05
4- Regularity in elevation	x		0
5- Quality control of materials		x	0.05
6- Quality control of execution		x	0.1

So $\rightarrow Q_x=Q_y=1.2$

➤ **Total weight of the structure (W) :**

Total weight of the structure equal to the sum of the weights calculated at each level (i).

$$W=\sum W_i$$

With:

$$W_i = W_{Gi} + \beta W_{Qi}$$

And: $i=1,2,3,\dots,n$

W_{Gi} : Weight due to permanent loads.

W_{Qi} : Operating expenses.

β : Weighting coefficient depending on the nature and duration of the operating load as given in table 4.5 RPA99/V2003.

Residential buildings, offices or similar buildings so: $\beta = 0.2$

Table V.7 Mass summary by story

Table V.7 Mass Summary by Story			
Story	Diaphragm	Mass	pois
		kg	kN
Story7	D1	293566.8	2879.89
Story6	D1	317360.26	3113.30
Story5	D1	319900.71	3138.22
Story4	D1	319900.71	3138.22
Story3	D1	319900.71	3138.22
Story2	D1	319900.71	3138.22
Story1	D1	319238.78	3131.73
Total weight			21677.8

The total weight $W=W_x=W_y= 21677.8 \text{ KN}$

So:

- **Seismic force for the direction x**

$$V_x = C_x \times W_x = \frac{A \times D_x \times Q}{R} \times W_x$$

$$V_x = \frac{0.25 \times 1.65 \times 1.2}{5} \times 21677.8$$

$$\rightarrow V_x = 2146.1 \text{ KN}$$

- **Seismic force for the direction y**

$$V_y = C_y \times W_y = \frac{A \times D_y \times Q}{R} \times W_y$$

$$V_y = \frac{0.25 \times 1.91 \times 1.2}{5} \times 21677.8$$

$$\rightarrow V_y = 2484.27 \text{ KN}$$

V.6 Response spectrum method : (RPA99V2003 art 4.3)

The dynamic study consists of determining the vibration characteristics, which can develop in a given construction, with a view to estimating the seismic load of worst-case calculation.

The method of spectral modal analysis may be used in all cases, and in particular, in cases where the equivalent static method is not permitted.

This method looks for up to forces generated in the structure by seismic forces represented by the spectrum of design responses for each vibrational mode, these efforts are then combined to produce a frame response.

V.6.1 Modeling :

For structures non-regular in plan, subject to torsion and having rigid floors, they are represented by a three-dimensional model, embedded at the base and where the masses are concentrated at the centre of gravity of the floors with three (03) DDL (2 translations horizontal and vertical axis rotation).

V.6.2 Calculated response spectrum :

The seismic action is represented by the following calculation spectrum:

$$\frac{s_a}{g} = \begin{cases} 1.25 \times A \times \left(1 + \frac{T}{T_1} \times (2.5 \times \eta) \times \frac{Q}{R} - 1\right) & 0 \leq T \leq T_1 \\ 2.5 \times \eta \times (1.25 \times A) \times \frac{Q}{R} & T_1 \leq T \leq T_2 \\ 2.5 \times \eta \times (1.25 \times A) \times \frac{Q}{R} \times \left(\frac{T_2}{T}\right)^{\frac{2}{3}} & T_2 \leq T \leq 3s \\ 2.5 \times \eta \times (1.25 \times A) \times \frac{Q}{R} \times \left(\frac{T_2}{T}\right)^{\frac{2}{3}} \times \left(\frac{3}{T}\right)^{\frac{5}{3}} & T \geq 3s \end{cases}$$

A: Acceleration coefficient of the zone.

Q: Quality factor.

R: Coefficient of overall behavior of the structure.

η : The damping correction factor.

T_1, T_2 : Characteristic periods associated with the site category.

T: Period calculated.

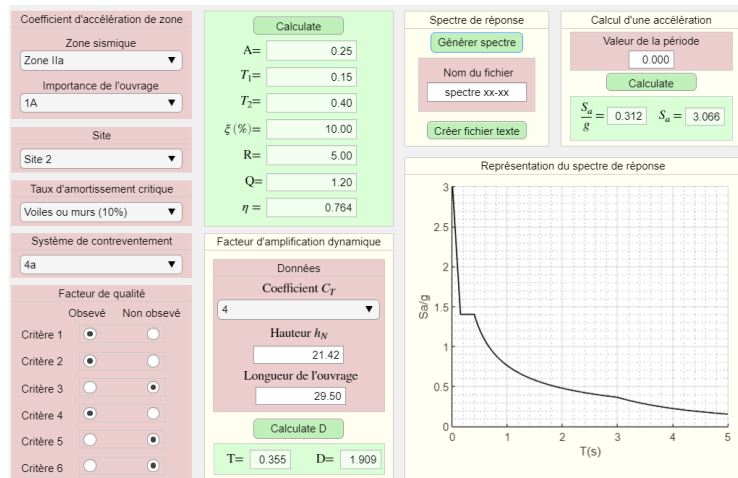

Figure V.12 Response spectrum parameters direction x

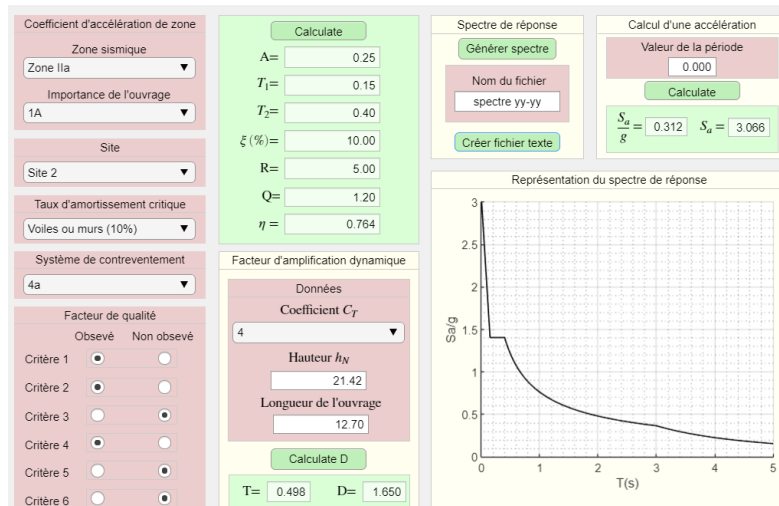

Figure V.13 Response spectrum parameters direction y

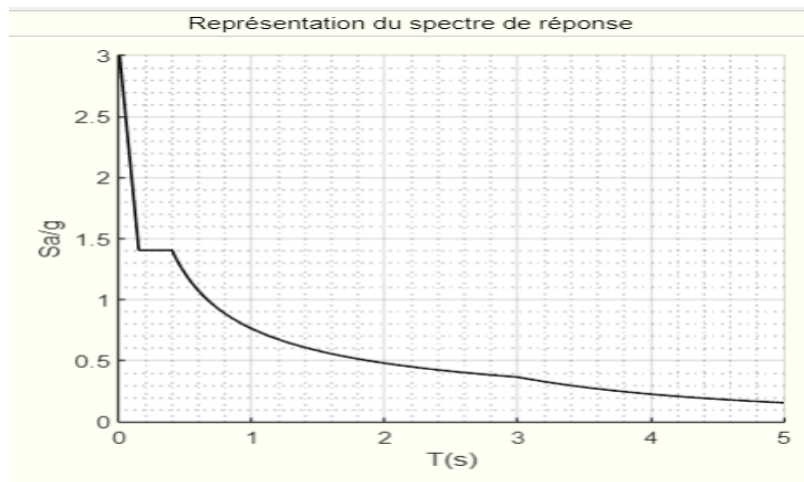

Figure V.14 Response spectrum direction x and y

V.6.3 Number of modes to consider : (RPA99V2003 art 4.3.4)

According to RPA99/version 2003 (article 4.3.4. a) for structures represented by planar models in two orthogonal directions, the number of modes of vibration to be retained in each of the two directions the excitation shall be such that:

The sum of the effective modal masses for the selected modes is equal to at least 90% of the total structural mass.

Or that all modes with an effective modal mass greater than 5% of the total structural mass is used to determine the total response of structure.

The minimum number of modes to remember is three (03) in each direction considered.

Table V.8 Number of modes

TABLE: Modal Participating Mass Ratios							
Case	Mode	Period	UX	UY	RZ	SumUX	SumUY
		sec					
Modal	1	0.701	0.7452	0.0009	0.0001	0.7452	0.0009
Modal	2	0.54	0.0012	0.7221	0.0108	0.7464	0.7231
Modal	3	0.39	0.0003	0.0066	0.6988	0.7467	0.7296
Modal	4	0.229	0.00004731	0.0197	0.0003	0.7467	0.7493
Modal	5	0.197	0.1333	0.0004	0	0.88	0.7497
Modal	6	0.184	0.0042	0.0366	0.0039	0.8842	0.7863
Modal	7	0.164	0.0001	0.0007	0.0202	0.8843	0.7871
Modal	8	0.134	0.0003	0.0034	0.0004	0.8846	0.7905
Modal	9	0.126	0.0003	0.0081	0.0002	0.8849	0.7985
Modal	10	0.121	0.0036	0.0177	0.0106	0.8886	0.8163
Modal	11	0.116	0.0007	0.0059	0.0018	0.8892	0.8222
Modal	12	0.114	0.0001	0.000001839	0.0008	0.8893	0.8222
Modal	13	0.095	0.0433	0.0054	0.0124	0.9327	0.8276
Modal	14	0.092	0.0028	0.0746	0.0295	0.9354	0.9022

✚ The sum of the effective modal masses:

- Direction X : Mode 13 → sum x = 0.9327
- Direction Y : Mode 14 → sum y = 0.9022

✚ Behavior checks for the first three modes:

Mode1: $U_x = 0.7452$; $U_y = 0.0009$; $R_z = 0.0001$

So, this mode is translation in X-X.

Mode2: $U_x = 0.0012$; $U_y = 0.7221$; $R_z = 0.0108$

So, this mode is translation in Y-Y.

Mode3: $U_x = 0.0003$; $U_y = 0.0066$; $R_z = 0.6988$

So, this mode is rotation.

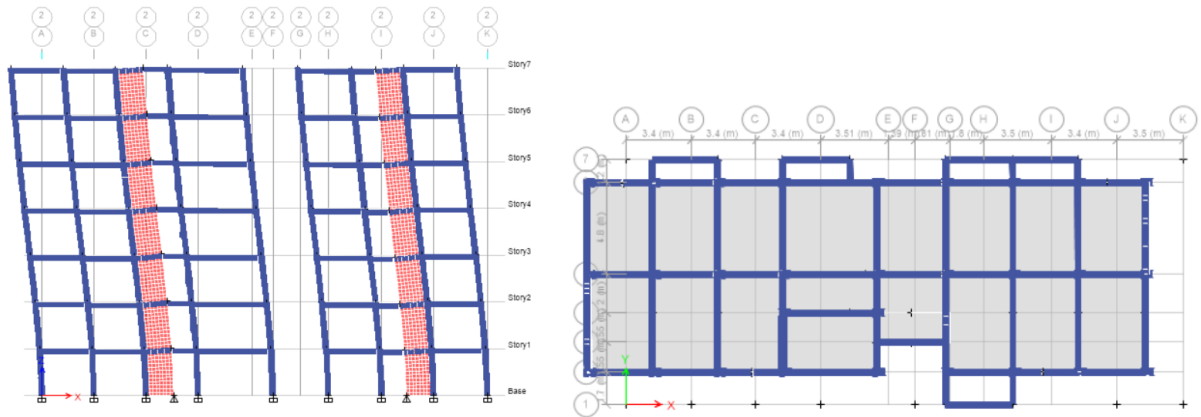

Figure V.15 View mode 1 Translation in direction x-x

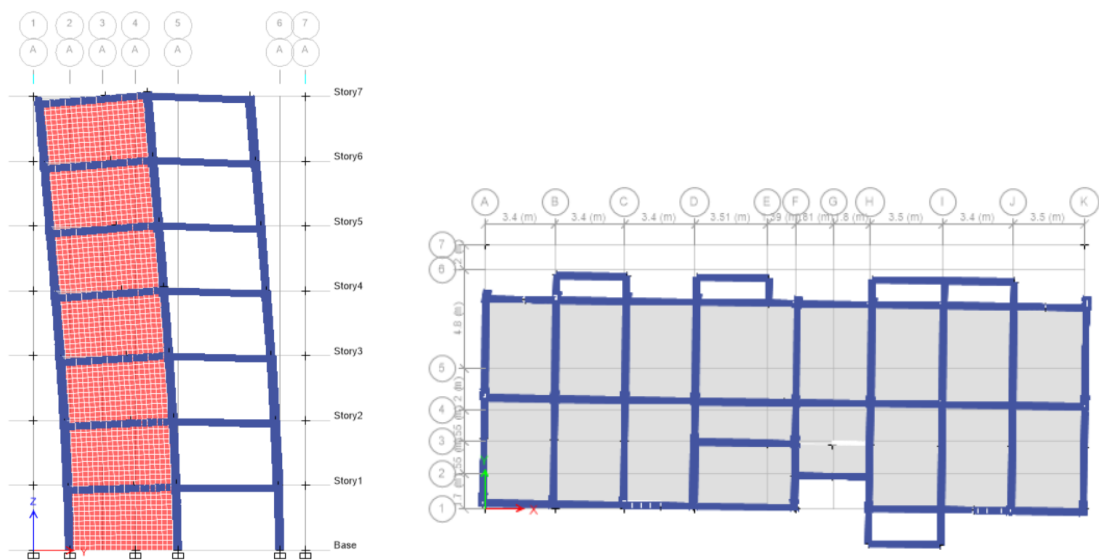

Figure V.16 View mode 2 Translation in direction y-y

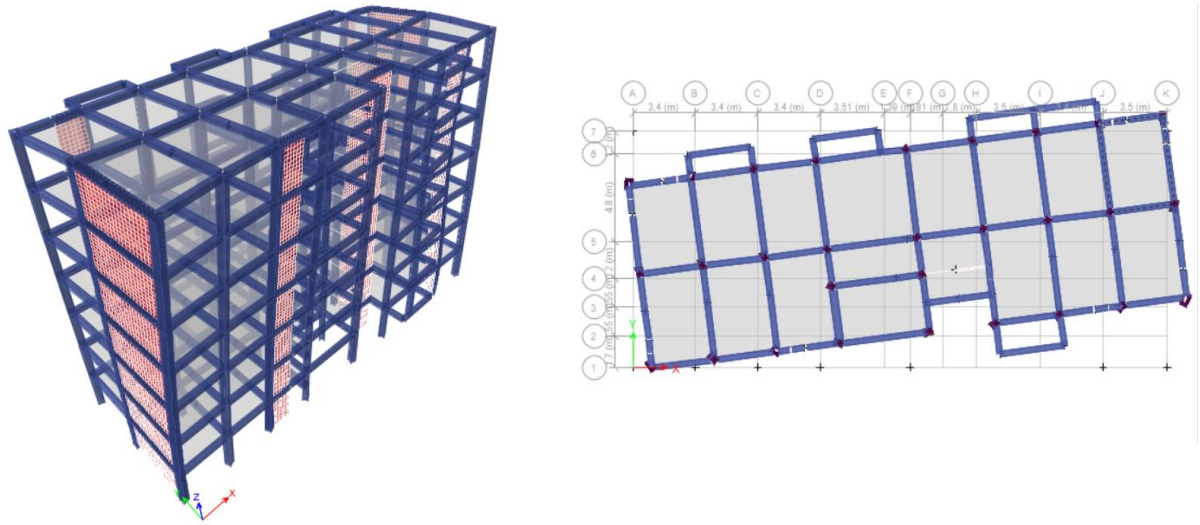

Figure V.17 View mode 3 Rotation

V.6.4 Justification for estimating the fundamental period : (RPAV2003 art 4.2.4)

- $T_{Analytical} \leq T_{emp} \rightarrow T = T_{Analytical}$
- $T_{emp} \leq T_{Analytical} \leq 1.3 T_{emp} \rightarrow T = T_{emp}$
- $T_{Analytical} \geq 1.3 T_{emp} \rightarrow T = 1.3 T_{emp}$

Table V.9 Verification of the fundamental period

	$T_{emp}(s)$	$T_{Analytical}(s)$	$1.3T_{emp}(s)$	$T_{Analytical} \geq 1.3 T_{emp}$	$T(s)$
x-x	0.4978	0.701	0.64714	CV	0.6471
y-y	0.355	0.54	0.4615	CV	0.4615

V.6.5 Effects of accidental torsion:

The effects of inadvertent vertical axis torsion should be considered when analysis using plane models is conducted in both orthogonal directions, as stated in paragraph (4.2.7 of Version 2003 (RPA99)).

Within the case of a three-dimensional investigation, in expansion to the calculated hypothetical whimsy, an additional coincidental flightiness rise to $\pm 0.05 L$ (L being connected at the level of the floor considered and concurring to each course).

V.6.6 The arrangement of the walls :

The choice of positioning of the Walls must be symmetry as far as possible and satisfy a certain number of conditions:

- The number should be large enough to ensure that the is stiff enough while being inexpensive, and that the is easy to handle.
- The position of these walls must avoid damaging torsional forces for the structure.

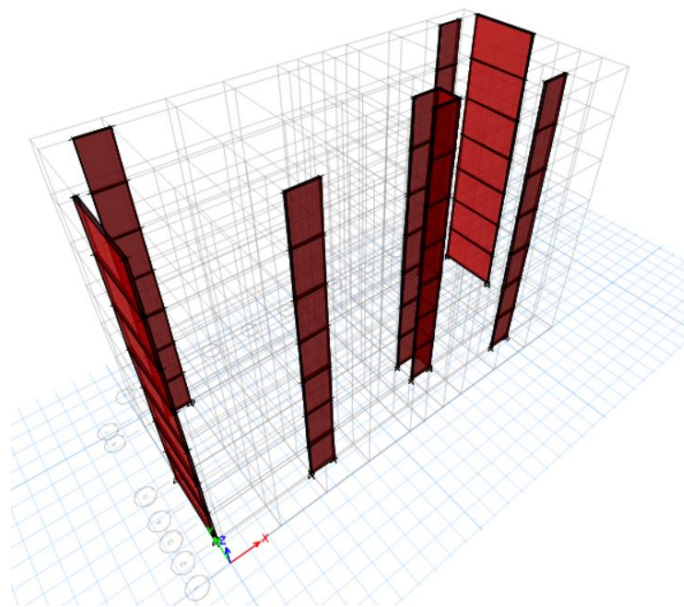

Figure V.18 The arrangement of the sails in 3D

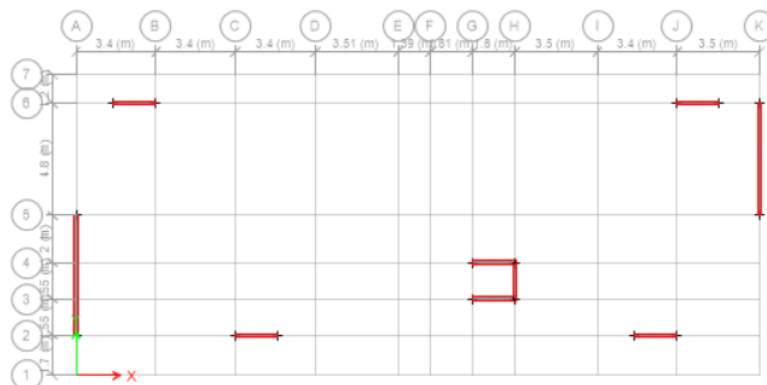

Figure V.19 The arrangement of the sails in plan

V.6.7 Results of dynamic analysis by ETABS :

➤ **Verification of resultant of seismic computing forces : (RPA99V2003 art 4.3.6)**

The resultant of seismic forces at base V_t obtained by combining modal values does not shall not be less than 80 % of the resultant seismic forces determined by the method equivalent

static V for a value of the fundamental period given by the formula appropriate empirical.

If $V_t < 0.80 V$, it will be necessary to increase all the parameters of the response (forces, displacements, moments,...) in the report $r = \frac{0.8V}{V_t}$

According to ETABS:

Table V.10 seismic computing forces

TABLE: Base Reactions				
Output Case	Step Type	FX	FY	FZ
		kN	kN	kN
Ex	Max	1821.7858	159.1504	0
Ey	Max	148.2992	1919.7165	0

➤ $V_{Dx} = \sqrt{F_X^2 + F_Y^2} = \sqrt{(1821.7858)^2 + (159.1504)^2} = 1828.72 \text{ KN}$

$0.8 V_{STx} = 0.8 \times 2146.1 = 1716.88 \text{ KN}$

We need to check that: $V_{Dx} > 0.8 V_{STx}$

$\Rightarrow 1828.72 > 1716.88 \dots \dots \dots \text{CV}$

➤ $V_{Dy} = \sqrt{F_X^2 + F_Y^2} = \sqrt{(148.2992)^2 + (1919.7165)^2} = 1925.44 \text{ KN}$

$0.8 V_{STy} = 0.8 \times 2484.27 = 1987.416 \text{ KN}$

$\Rightarrow V_{Dy} > 0.8 V_{STx} \dots \dots \dots \text{CNV}$

So according to RPA If $V_t < 0.80 V$, it will be necessary to increase all the response parameters (forces, displacements, moments...) in the ratio $0.8 V/V_t$

$\alpha = \frac{1987.416}{1925.44} = 1.03$

So, we will go to load cases and multiply Ey in this coefficient.

Table V.11 seismic computing forces

TABLE: Base Reactions				
Output Case	Step Type	FX	FY	FZ
		kN	kN	kN
Ex	Max	1821.7858	159.1504	0
Ey	Max	157.3303	2036.6225	0

$$\triangleright V_{Dy} = \sqrt{F_X^2 + F_Y^2} = \sqrt{(157.3303)^2 + (2036.6225)^2} = 2042.69 \text{ KN}$$

$$0.8 V_{STy} = 0.8 \times 2484.27 = 1987.416 \text{ KN}$$

$$\Rightarrow 2042.69 > 1987.416 \dots\dots\dots CV$$

V.7 Requirements common to methods "static" and "dynamic" :

V.7.1 Justification of the choice of shear walls :

Shear walls system consisting of load-bearing reinforced concrete walls, (the System 2), this system stipulates that shear walls take more than 20% of the stresses due to vertical loads.

According to ETABS: after draw a section cut, we get:

$$P_T = 21075.7318 \text{ KN}$$

$$P_{wall} = 5567.5735 \text{ KN}$$

$$\frac{P_{wall}}{P_T} = \frac{5567.5735}{21075.7318} = 0.26 = 26\% > 20\% \dots\dots\dots CV$$

So, the shear walls system is justified.

V.7.2 Verification of renversement stability : (RPA99V2003 art 4.4.1)

It is not necessary to do this check in static equivalent method because this method is not applicable so we will do this check just in the dynamic method.

The inversion moment which will be caused by the seismic activity should be calculated by connection to soil-foundation contact level.

It must be verified that: $\frac{M_{Stability}}{M_{Renversement}} \geq 1.5$

Table V.12 The moments of renversement

TABLE: Base Reactions			
Output Case	Case Type	MX	MY
		kN-m	kN-m
Ex	LinRespSpec	1692.4116	27422.5851
Ey	LinRespSpec	31424.0202	1566.0961

- The moment of renversement in the direction X is equal to: $M_y = 27422.5851 \text{ KN.m}$
- The moment of renversement in the direction Y is equal to: $M_x = 31424.0202 \text{ KN.m}$

TableV.13 The moments of stability

TABLE: Base Reactions			
aOutput Case	Case Type	MX	MY
		kN-m	kN-m
ELS	Combination	168349.2064	-359965.9769

- The moment of stability in the direction X is equal to: $M_x = 168349.2064$
- The moment of stability in the direction Y is equal to: $M_y = 359965.9769$

Direction x:

$$\frac{M_x \text{ Stability}}{M_x \text{ Renversement}} = \frac{168349.2064}{27422.5851} = 6.13 \geq 1.5 \dots\dots\dots \text{CV}$$

Direction y:

$$\frac{M_y \text{ Stability}}{M_y \text{ Renversement}} = \frac{359965.9769}{31424.0202} = 11.45 \geq 1.5 \dots\dots\dots \text{CV}$$

V.7.3 Calculation of displacements : (RPA99V2003 art.4.4.3)

The horizontal displacement at each level "k" of the structure is calculated as follows:

$$\delta_k = R \times \delta_{ek}$$

δ_{ek} : Displacement due to seismic forces F_i (including torsional effect).

R: Coefficient of overall behavior of the structure.

The relative displacement at level "k" from level "k-1" is equal to:

$$\Delta k = \delta_k - \delta_{k-1}$$

- Under force E_x :

Table V.14 Maximum Story Displacement under force E_x

TABLE: Story Response							
Story	Elevation	$\delta_{ek} dx$	R	$\delta_k = \delta_{ek} \times R$	$\Delta k = \delta_k - \delta_{k-1}$	$\bar{\Delta} = 0.01hk$	$\Delta k \leq \bar{\Delta}$
	m	mm		mm	mm	mm	
Story7	3.06	18.356	5	91.78	11.47	30.6	CV
Story6	3.06	16.062	5	80.31	13.115	30.6	CV
Story5	3.06	13.439	5	67.195	15.06	30.6	CV
Story4	3.06	10.427	5	52.135	16.29	30.6	CV
Story3	3.06	7.169	5	35.845	16.01	30.6	CV
Story2	3.06	3.967	5	19.835	13.435	30.6	CV
Story1	3.06	1.28	5	6.4	6.4	30.6	CV

- Under force E_y :

Table V.15 Maximum Story Displacement under force E_y

TABLE: Story Response							
Story	Elevation	$\delta_{ek} dy$	R	$\delta_k = \delta_{ek} \times R$	$\Delta k = \delta_k - \delta_{k-1}$	$\bar{\Delta} = 0.01hk$	$\Delta k \leq \bar{\Delta}$
	m	mm		mm	mm	mm	
Story7	3.06	13.366	5	66.83	1.45	30.6	CV
Story6	3.06	13.076	5	65.38	5.62	30.6	CV
Story5	3.06	11.952	5	59.76	11.54	30.6	CV
Story4	3.06	9.644	5	48.22	14.895	30.6	CV
Story3	3.06	6.665	5	33.325	16.09	30.6	CV
Story2	3.06	3.447	5	17.235	13.385	30.6	CV
Story1	3.06	0.77	5	3.85	3.85	30.6	CV

Story Response - Maximum Story Displacement

Summary Description

This is story response output for a specified range of stories and a selected load case or load combination.

Input Data

Name	StoryResp1		
Display Type	Max story displ	Story Range	All Stories
Load Case	Ey	Top Story	Story7
Output Type	Not Applicable	Bottom Story	Base

Plot

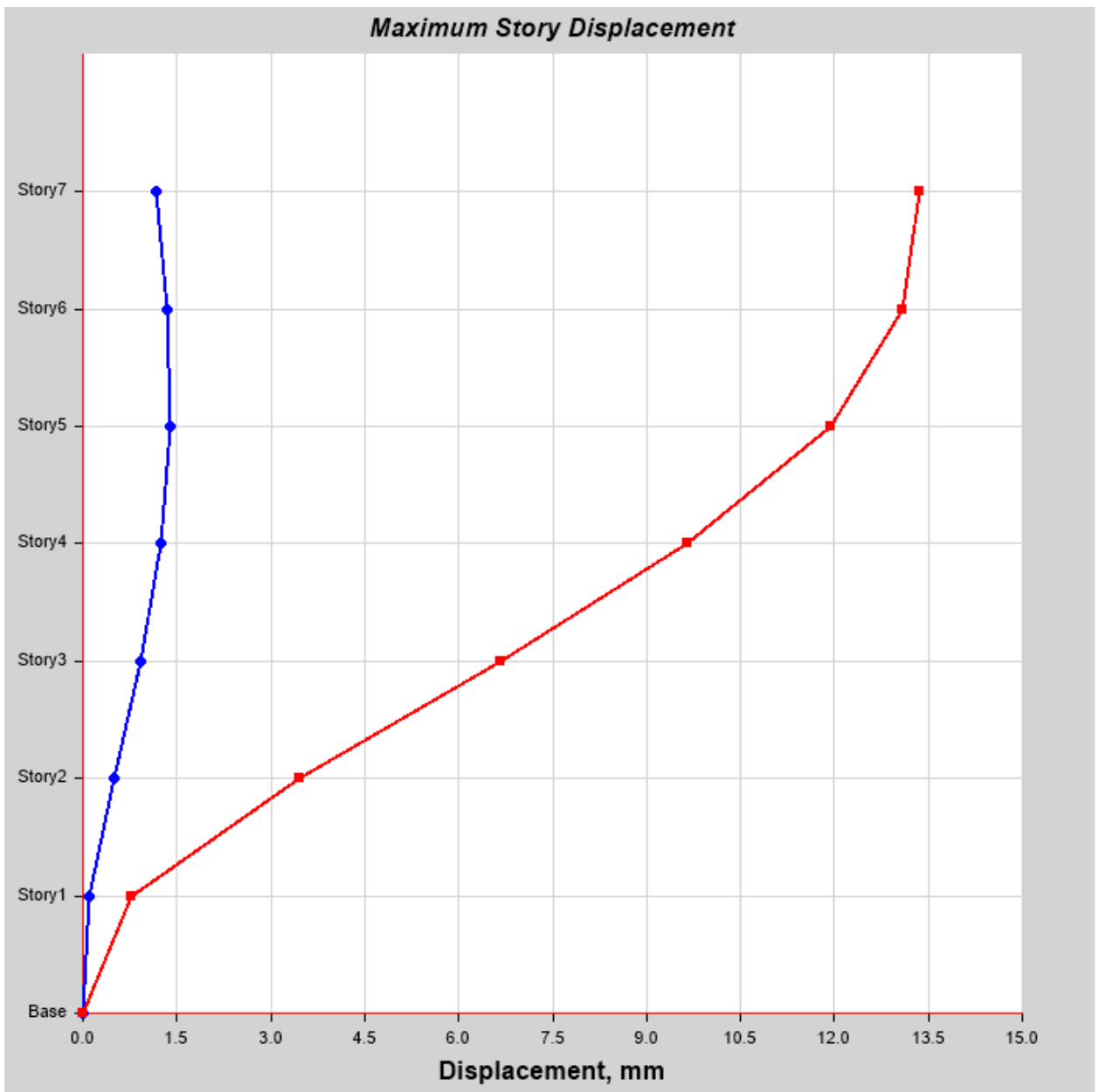

Tabulated Plot Coordinates

Story Response - Maximum Story Displacement

Summary Description

This is story response output for a specified range of stories and a selected load case or load combination.

Input Data

Name	StoryResp3		
Display Type	Max story displ	Story Range	All Stories
Load Case	Ex	Top Story	Story7
Output Type	Not Applicable	Bottom Story	Base

Plot

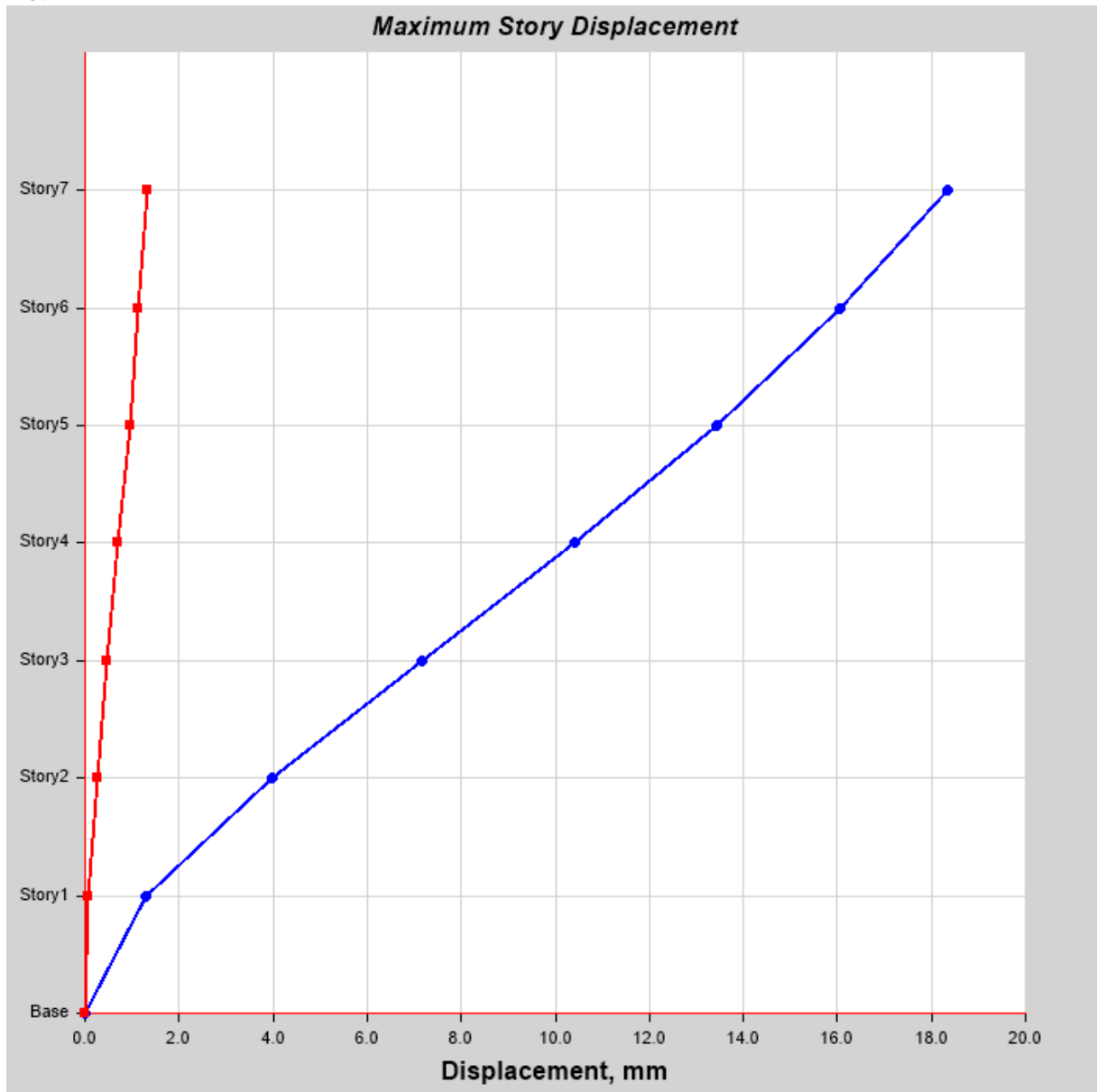

Tabulated Plot Coordinates

V.7.4 Verification of the effect P – Δ : (RPA99V2003 art 5.9)

The second order effect P – Δ can be neglected in the case of building if the following condition is satisfied for each level.

$$\theta = \frac{P_k \Delta k}{V_k \cdot h_k} \leq 0.1$$

P_k : Total weight of structure and associated operating costs above level k

$$P_k = \sum_{i=k}^n (W_{Gi} + \beta \cdot W_{Qi})$$

V_k : Shear force of each story.

Δk : Relative displacement of story k compared to story k-1.

h_k : Story height k.

- **Direction X**

Table V.16 The effect P – Δ in direction x

TABLE: Mass Summary by Story						
Story	P_k	Δk	shear x	h_k	θ	$\theta < 0.1$
	kN	mm	KN	mm		
Story7	2879.89	11.47	512.8407	3060	0.021	CV
Story6	3113.30	13.115	899.5228	3060	0.015	CV
Story5	3138.22	15.06	1202.6288	3060	0.013	CV
Story4	3138.22	16.29	1450.2341	3060	0.011	CV
Story3	3138.22	16.01	1633.8853	3060	0.010	CV
Story2	3138.22	13.435	1764.1018	3060	0.0078	CV
Story1	3131.73	6.4	1821.7858	3060	0.0035	CV

- **Direction Y**

Table V.17 The effect P – Δ in direction y

TABLE: Mass Summary by Story						
Story	P_k	Δk	shear y	h_k	θ	$\theta < 0.1$
	kN	mm	KN	mm		
Story7	2879.89	1.45	488.5165	3060	0.0027	CV
Story6	3113.30	5.62	961.9409	3060	0.0059	CV
Story5	3138.22	11.54	1359.1067	3060	0.0087	CV
Story4	3138.22	14.895	1655.7041	3060	0.0092	CV
Story3	3138.22	16.09	1863.8	3060	0.0088	CV
Story2	3138.22	13.385	1990.8976	3060	0.0068	CV
Story1	3131.73	3.85	2036.6225	3060	0.0019	CV

Story Response - Story Shears

Summary Description

This is story response output for a specified range of stories and a selected load case or load combination.

Input Data

Name	StoryResp3		
Display Type	Story shears	Story Range	All Stories
Load Case	Ex	Top Story	Story7
Output Type	Not Applicable	Bottom Story	Base

Plot

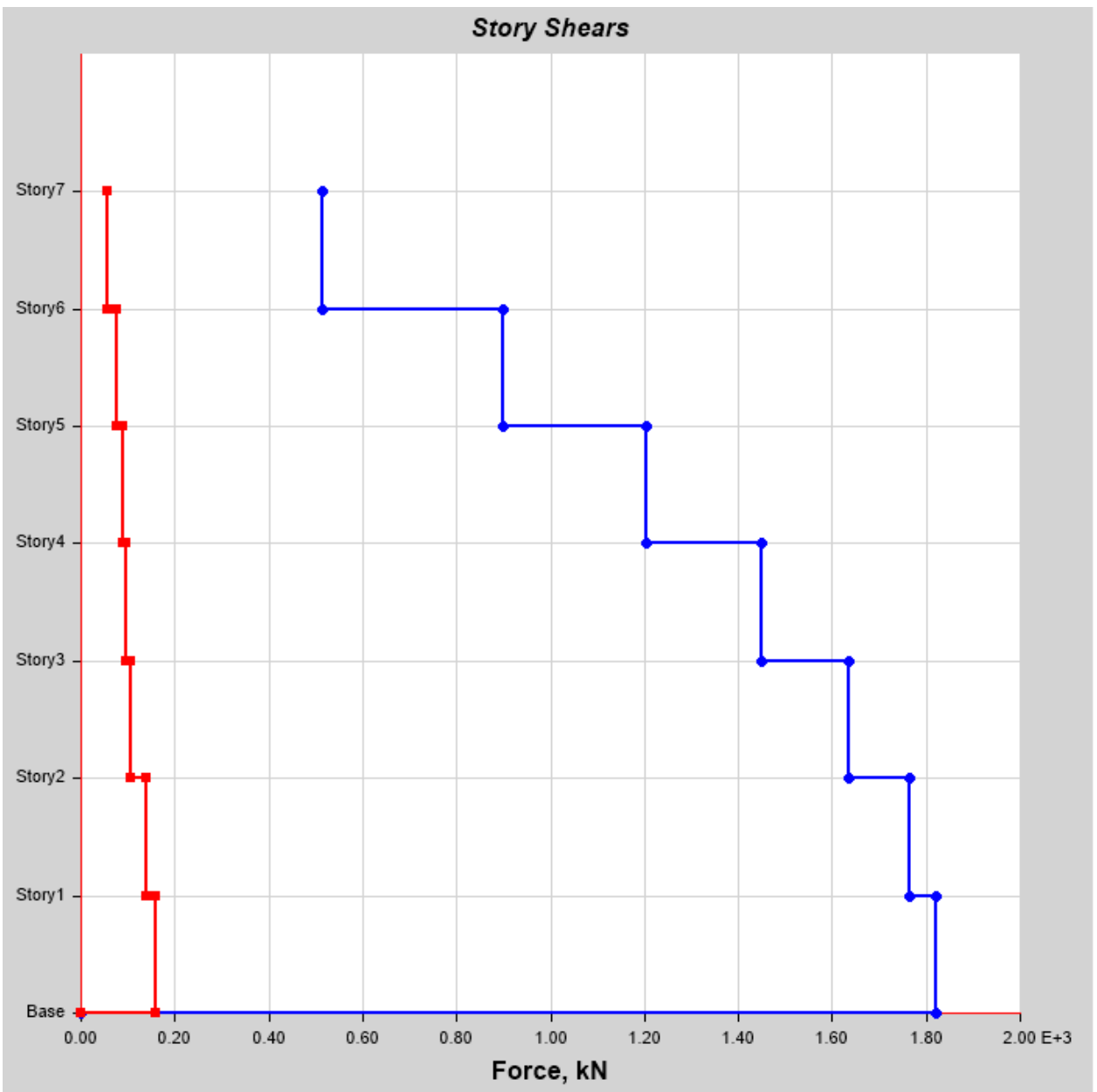

Story Response - Story Shears

Summary Description

This is story response output for a specified range of stories and a selected load case or load combination.

Input Data

Name	StoryResp4		
Display Type	Story shears	Story Range	All Stories
Load Case	Ey	Top Story	Story7
Output Type	Not Applicable	Bottom Story	Base

Plot

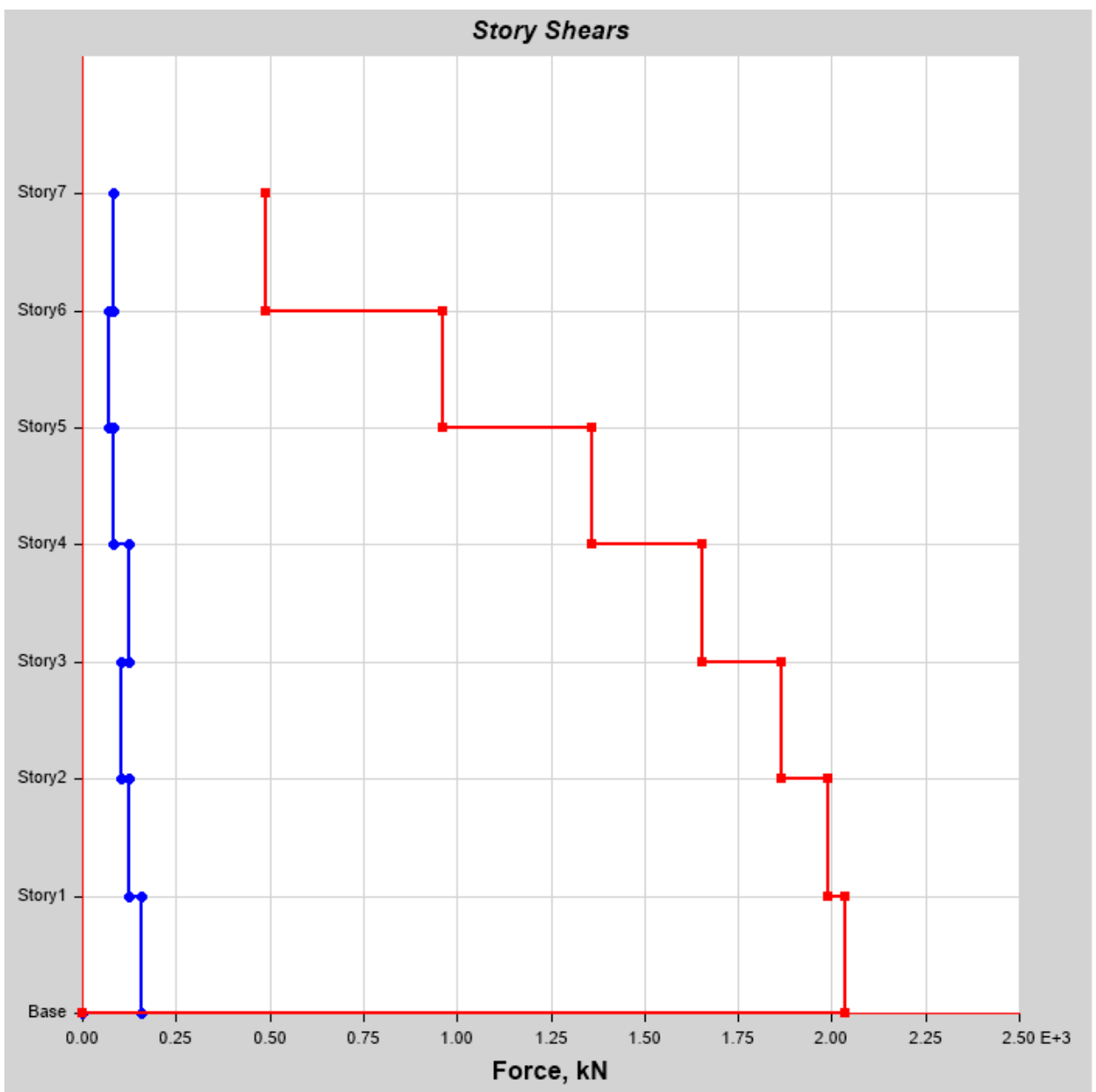

V.7.5 Verification of reduced normal effort N :

To limit the risk of rupture of vertical elements (column) under the action of the earthquake, the following condition must be met:

$$v = \frac{N_d}{B_c \times f_{c28}} \leq 0.30$$

With:

N_d : The normal effort exerted on a section of concrete.

B_c : The area of the gross section.

f_{c28} : The characteristic strength of concrete.

If the condition is not verified on one of the elements of a floor, it means that the element in question does not withstand the earthquake stress and must change the pre-defined pre-design.

Example of the calculation: for the columns of ground floor with the section (40×40)

Story	Column	P kN
Story1	C21	-1184.6752
Story1	C21	-1184.6752
Story1	C21	-1182.2272
Story1	C21	-1182.2272
Story1	C15	-1173.832
Story1	C15	-1173.832

Figure V.20 Element forces for columns

$$v = \frac{1184.6762 \times 10^{-3}}{0.40 \times 0.40 \times 25} = 0.29616 \leq 0.30 \dots\dots\dots CV$$

V.8 Conclusion :

Now after the arrangement of the shear walls and on the increase of the dimensions of the structural elements we are able to meet all the conditions required by RPA99V2003. This allows us to continue with the calculation of structural elements.

Chapter

VI

Chapter VI

Reinforcement of structural elements:

VI.1 Introduction :

The structure withstands gravity and seismic loads thanks to its main supporting elements, which consist of all stiffening elements: columns - beams and walls, these elements must be large enough, armed (remains) and well organized to receive all the various requests and forward them to the foundation.

Calculation of the beams :

They are horizontal structural elements that are designed to withstand and transfer loads applied perpendicular to their longitudinal axis. They play a crucial role in supporting the weight of floors, roofs, or other structural components in buildings

The beams are solicited in simple bending, sound a sharp force and a bending moment considering the cracking as being harmful, this allows the determination of the longitudinal reinforcements, the sharp force makes it possible to determine the transverse reinforcements.

VI.2 Reinforcements of the beams :

There are two types of beams, main and secondary. After determination of the stresses (M, N, T) reinforcement shall be carried out in accordance with the requirements given by the RPA/2003 and those given by the CBA93.

VI.2.1 Combination of reinforcement of beams :

Using the civil engineering software ETABS, the internal forces of each section of the elements for the different calculation combinations are determined:

- Combinations given by the **CBA93 art 6.1.2:**

$$\begin{cases} \mathbf{ULS} = \mathbf{1.35 G} + \mathbf{1.5 Q} \\ \mathbf{SLS} = \mathbf{G} + \mathbf{Q} \end{cases}$$

- Combinations given by the **RPA99V2003:**

$$\mathbf{G} + \mathbf{Q} + \mathbf{E}$$

(This combination gives a maximum negative moment in absolute value on the supports)

$$\begin{cases} \mathbf{0.8 G} + \mathbf{E} \\ \mathbf{0.8 G} - \mathbf{E} \end{cases}$$

(This combination gives a minimum negative or positive moment in absolute value on the supports)

With:

G: permanent loads. Q: Operating loads. E: Seismic loads

VI.2.2 Various regulatory recommendation and requirements for beams :

- **Longitudinal reinforcements :**

- The minimum reinforcement according to CBA93 (condition of non-fragility):

$$A_{min} = \frac{0.23 \times b \times d \times f_{t28}}{f_e}$$

- Percentage of steels according to (RPA 99V2003 art 7.5.2):
- The minimum total percentage of longitudinal steels along the entire length of the beam is 0.5% in any section, that is mean:

$$A_{RPAmin} = 0.005 \times b \times h$$
- The maximum total percentage of longitudinal steels is:
 - 4% of the concrete section in the running area.
 - 6% of the concrete section in the covering area.
- The minimum overlap length is $40 \times \emptyset$ (zone IIa)
- The anchoring of the upper and lower longitudinal reinforcements in the columns of angle and angle shall be made with 90° hooks.
- The node frames, arranged as transverse reinforcement for the columns, are made up of two superimposed U forming a square or rectangle.

• **Transverse reinforcements : (RPA99V2003 art 7.5.2.2)**

- ✓ The minimum quantity of transverse reinforcement is given by:

$$A_t = 0.003 \times S_t \times b$$

- ✓ The maximum spacing between the transverse reinforcements is given as follows:

$$S_t = \min (h/4; 12 \times \emptyset_1) \text{ in the nodal zone.}$$

$$S_t \leq h / 2: \text{ outside the nodal zone.}$$

- ✓ The value of the diameter \emptyset_1 is the smallest diameter used.
- ✓ The first transverse reinforcements must be placed not more than 5 cm from the bare of support or embedding.

• **Verification of shear stresses :**

The shear stress is given by:

$$\tau_u = \frac{V_u}{b \times d} \leq \bar{\tau}_u$$

$-\bar{\tau}_u = \min (0.2 f_{c28} / \gamma_b; 5 \text{ MPa})$ minimally detrimental cracking.

$-\bar{\tau}_u = \min (0.15 f_{c28} / \gamma_b; 4 \text{ MPa})$ detrimental or very detrimental cracking. (2.2MPa)

VI.2.3 Calculation of main beams : (30 × 35) cm²

The beams are calculated in simple bending by considering the combinations above with:

ULS :

The Poisson's coefficient is: $\nu = 0$ for:

$$\begin{cases} 1.35G + 1.5Q \\ 0.8G \pm E \\ G + Q \pm E \end{cases}$$

Mechanical Property Data	
Modulus of Elasticity, E	32164.2 MPa
Poisson's Ratio, U	0
Coefficient of Thermal Expansion, A	0 1/C
Shear Modulus, G	16082.1 MPa

Figure VI.1 The Poisson's coefficient at ULS

SLS :

The Poisson coefficient is: $\nu = 0.2$ for: G+Q

Mechanical Property Data	
Modulus of Elasticity, E	32164.2 MPa
Poisson's Ratio, U	0.2
Coefficient of Thermal Expansion, A	0 1/C

Figure VI.2 The Poisson's coefficient at SLS

The maximum stresses used From ETABS are:

Table VI.1 Maximum loads for main beams

Combination	M_{span} (KN.m)	$M_{support}$ (KN.m)	V (KN.m)
ULS	39.5581	-51.5369	53.7977
SLS	28.7211	-37.4546	-39.1268
$G + Q \pm E$	82.7419	-111.4879	137.7172
$0.8G \pm E$	76.6446	-100.8512	129.3995

VI.2.3.1 Longitudinal reinforcements :**ULS :**

($h=35$ cm, $b=30$ cm, $d=0.9 \times h=31.5$ cm, $f_{bc}=14.2$ MPa, $\sigma_s=348$ MPa)

On Span :

$$M_{span} = 39.5581 \text{ KN.m}$$

$$\mu = \frac{M_{span}}{b \times d^2 \times f_{bc}}$$

$$\mu = \frac{39.5581 \times 10^{-3}}{0.30 \times 0.315^2 \times 14.2} = 0.093 < \mu_l = 0.391 \rightarrow A'_s = 0$$

$$\mu = 0.093 < 0.186 \rightarrow \text{Pivot A}$$

$$\alpha_u = 1.25 \times (1 - \sqrt{1 - 2\mu})$$

$$\alpha_u = 1.25 \times (1 - \sqrt{1 - 2 \times 0.093}) = 0.122$$

$$\beta = 0.8 \times \alpha_u = 0.0976$$

$$A_s = \beta \times b \times d \times \frac{f_{bc}}{\sigma_s}$$

$$A_s = 0.0976 \times 0.3 \times 0.315 \times \frac{14.2 \times 10^4}{348} = 3.76 \text{ cm}^2$$

On support :

$$M_{\text{support}} = 51.5369 \text{ KN.m}$$

$$\mu = \frac{M_{\text{span}}}{b \times d^2 \times f_{bc}}$$

$$\mu = \frac{51.5369 \times 10^{-3}}{0.30 \times 0.315^2 \times 14.2} = 0.122 < \mu_l = 0.391 \rightarrow A'_s = 0$$

$$\mu = 0.122 < 0.186 \rightarrow \text{Pivot A}$$

$$\alpha_u = 1.25 \times (1 - \sqrt{1 - 2\mu})$$

$$\alpha_u = 1.25 \times (1 - \sqrt{1 - 2 \times 0.122}) = 0.163$$

$$\beta = 0.8 \times \alpha_u = 0.1304$$

$$A_s = \beta \times b \times d \times \frac{f_{bc}}{\sigma_s}$$

$$A_s = 0.1304 \times 0.3 \times 0.315 \times \frac{14.2 \times 10^4}{348} = 5.03 \text{ cm}^2$$

$$A_s = 5.03 \text{ cm}^2$$

Calculation of reinforcement on the upper layer of the support :

G+Q+E

$$(h=35 \text{ cm}, b=30 \text{ cm}, d=0.9 \times h=31.5 \text{ cm}, f_{bc}=18.48 \text{ MPa}, \sigma_s=400 \text{ MPa})$$

$$M_{\text{support}} = 111.4879 \text{ KN.m}$$

$$\mu = \frac{M_{\text{supp}}}{b \times d^2 \times f_{bc}}$$

$$\mu = \frac{111.4879 \times 10^{-3}}{0.30 \times 0.315^2 \times 18.48} = 0.203 < \mu_l = 0.391 \rightarrow A'_s = 0$$

$$\mu = 0.203 > 0.186 \rightarrow \text{Pivot B}$$

$$\alpha_u = 1.25 \times (1 - \sqrt{1 - 2\mu})$$

$$\alpha_u = 1.25 \times (1 - \sqrt{1 - 2 \times 0.203}) = 0.287$$

$$\beta = 0.8 \times 0.287 = 0.2296$$

$$A_s = 0.2296 \times 0.3 \times 0.315 \times \frac{18.48 \times 10^4}{400} = 10.02 \text{ cm}^2$$

$$A_s = 10.02 \text{ cm}^2$$

Calculation of reinforcement on the lower layer of the support :

0.8G + E

$$M_{\text{support}} = 100.8512 \text{ KN.m}$$

$$\mu = \frac{M_{\text{supp}}}{b \times d^2 \times f_{bc}}$$

$$\mu = \frac{100.8512 \times 10^{-3}}{0.30 \times 0.315^2 \times 18.48} = 0.183 < \mu_l = 0.391 \rightarrow A'_s = 0$$

$$\mu = 0.183 < 0.186 \rightarrow \text{Pivot A}$$

$$\alpha_u = 1.25 \times (1 - \sqrt{1 - 2\mu})$$

$$\alpha_u = 1.25 \times (1 - \sqrt{1 - 2 \times 0.183}) = 0.255$$

$$\beta = 0.8 \times \alpha_u = 0.204$$

$$A_s = 0.204 \times 0.3 \times 0.315 \times \frac{18.48 \times 10^4}{400} = 8.91 \text{ cm}^2$$

$$A_s = 8.91 \text{ cm}^2$$

VI.2.3.2 Verification required :

➤ Condition of non-fragility:(CBA93)

$$A_s \text{ min} = \frac{0.23 \times b \times d \times f_{t28}}{f_e} = \frac{0.23 \times 0.3 \times (0.9 \times 0.35) \times 2.1}{400} = 1.14 \times 10^{-4} \text{ m}^2 = 1.14 \text{ cm}^2$$

$$\text{So: } A_s \text{ min} = 1.14 \text{ cm}^2$$

➤ Minimum section of steels (RPA99V2003) :

$$A_s \text{ min RPA} = 0.5\% b \times h$$

$$A_s \text{ min RPA} = \frac{0.5}{100} \times 30 \times 35 = 5.25 \text{ cm}^2$$

$$\text{So: } A_s \text{ min RPA} = 5.25 \text{ cm}^2$$

On span:

$$A_s = \max(A_s, A_s \text{ min}, A_s \text{ min RPA}) = \max(3.76; 1.14; 5.25) = 5.25 \text{ cm}^2$$

So, we take:

$$A_s \text{ span} = 3\text{HA}16 = 6.03 \text{ cm}^2$$

Reinforcement on upper layer supports :

$$A_s = \max (A_s, A_s \text{ min}, A_s \text{ min RPA}) = \max (10.02; 1.14; 5.25) = 10.02 \text{ cm}^2$$

So, we take:

$$A_{s \text{ sup}} = 3\text{HA16}+3\text{HA14}=10,65 \text{ cm}^2$$

Reinforcement on lower layer supports :

$$A_s = \max (A_s, A_s \text{ min}, A_s \text{ min RPA}) = \max (8.91; 1.14 ; 5.25) = 8.91 \text{ cm}^2$$

So, we take:

$$A_{s \text{ sup}} = 3\text{HA16}+2\text{HA14}=9,11 \text{ cm}^2$$

➤ **The maximum percentage of steels (RPA99/2003 a.7.5.2.1)**

$$A_s \leq A_{s \text{ Max}}$$

$$A_{s \text{ Max}} = 0.04 \times b \times h \rightarrow \text{In the current zone.}$$

$$A_{s \text{ Max}} = 0.06 \times b \times h \rightarrow \text{In the overlap area.}$$

→ **In the current zone :**

$$A_{s \text{ Max}} = 0.04 \times 30 \times 35$$

$$A_{s \text{ Max}} = 42 \text{ cm}^2$$

$$A_{s \text{ Max}} = 42 \text{ cm}^2 \geq A_{s \text{ sup}} = 10.65 \text{ cm}^2 \rightarrow \text{CV}$$

$$A_{s \text{ Max}} = 42 \text{ cm}^2 \geq A_{s \text{ span}} = 6.03 \text{ cm}^2 \rightarrow \text{CV}$$

→ **In the overlap area :**

$$A_{s \text{ Max}} = 0.06 \times 30 \times 35$$

$$A_{s \text{ Max}} = 63 \text{ cm}^2$$

$$A_{s \text{ Max}} = 63 \text{ cm}^2 \geq A_{s \text{ sup}} = 10.65 \text{ cm}^2 \rightarrow \text{CV}$$

$$A_{s \text{ Max}} = 63 \text{ cm}^2 \geq A_{s \text{ span}} = 6.03 \text{ cm}^2 \rightarrow \text{CV}$$

- **overlap length**

In (Zone IIa)

$$L = 40 \times \emptyset$$

$$L1 = 40 \times 1.6 = 64 \text{ cm}$$

$$L2 = 40 \times 1.4 = 56 \text{ cm.}$$

- **Nodal zone length**

$$L' = 2 \times h = 2 \times 35 = 70 \text{ cm}$$

VI.2.3.3 Transverse reinforcements :

$$\phi_{tr} \leq \min \left\{ \frac{h}{35}; \phi_1; \frac{b}{10} \right\}$$

$$\phi_{tr} \leq \min \left\{ \frac{350}{35}; 16; \frac{300}{10} \right\} = \min \{10; 16; 30\} = 10 \text{ mm}$$

We take:

$$\phi_{tr} = 8 \text{ mm.}$$

Calculation of spacing :

- **CBA :**

$$S_t \leq \min (0.9d ; 40) = \min (31.5; 40)$$

$$S_t = 20 \text{ cm}$$

- **RPA :**

In the nodal zone :

$$S_t \leq \min (h/4; 12 \times \phi_1) = \min (8.75; 19.2) = 8.75 \text{ cm}$$

$$S_t = 8 \text{ cm.}$$

Outside the nodal zone :

$$S_t \leq \frac{h}{2}$$

$$S_t \leq \frac{35}{2}$$

$$S_t = 17.5 \text{ cm}$$

We choose: $S_t = 15 \text{ cm}$

Minimum cross-section of transverse steels :

$$A_t = 0.003 \times S_t \times b$$

In the nodal zone:

$$A_t = 0.003 \times 8 \times 30 = 0.72 \text{ cm}^2$$

Outside the nodal zone:

$$A_t = 0.003 \times 15 \times 30 = 1.35 \text{ cm}^2$$

For the both zones: $A_s = 4T8 = 2.01 \text{ cm}^2$

VI.2.3.4 Verification of shear force : (C.B.A 93 A.5.1.2.1)

$$\tau_u \leq \bar{\tau}_u$$

Minimally harmful cracking so:

$$\bar{\tau}_u \leq \left(0.2 \times \frac{f_{cj}}{\gamma_b}; 5 \text{ MPa} \right)$$

$$\bar{\tau}_u \leq (3.33; 5 \text{ MPa})$$

$$\bar{\tau}_u = 3.33 \text{ MPa.}$$

$$\tau_u = \frac{V}{b \times d}$$

$$\tau_u = \frac{137.7172 \times 10^{-3}}{0.3 \times 0.315} = 1.46 \text{ MPa} \leq \bar{\tau}_u \dots\dots\dots \text{CV}$$

VI.2.3.5 Service limit status check :

- As cracking is not harmful (little-harmful)CV
- The steel used is of grade FeE400.....CV
- The section is rectangular (30x35) CV
- Simple bending.....CV

If the following condition is met, the limitation of stresses in concrete will be unnecessary:

It must be verified that:

$$\alpha < \frac{\gamma-1}{2} + \frac{f_c 28}{100}$$

$$\text{With: } \gamma = \frac{M_u}{M_{ser}}$$

On span :

$$\alpha = 0.122$$

$$\alpha < \frac{\gamma-1}{2} + \frac{f_c 28}{100}$$

$$\gamma = \frac{39.5581}{28.7211} = 1.37$$

$$\alpha = 0.122 < \frac{1.37-1}{2} + \frac{25}{100} = 0.435 \dots\dots\dots \text{CV}$$

On the upper layer of the support :

$$\alpha = 0.287$$

$$\alpha < \frac{\gamma-1}{2} + \frac{f_c 28}{100}$$

$$\gamma = \frac{111.4879}{37.4546} = 2.97$$

$$\alpha = 0.287 < \frac{2.97-1}{2} + \frac{25}{100} = 1.235 \dots\dots\dots \text{CV}$$

On the lower layer of the support :

$$\alpha = 0.255$$

$$\alpha < \frac{\gamma-1}{2} + \frac{f_c 28}{100}$$

$$\gamma = \frac{100.8512}{37.4546} = 2.69$$

$$\alpha = 0.255 < \frac{2.69-1}{2} + \frac{25}{100} = 1.095 \dots\dots\dots \text{CV}$$

All conditions are verified so there is not verification at SLS.

➤ **Arrow verification :**

It is not necessary to check the arrow of the three condition listed below are verified simultaneously.

- $\frac{h}{L} \geq \frac{1}{16} \rightarrow \frac{0.35}{5} = 0.07 \geq \frac{1}{16} = 0.0625 \dots\dots\dots CV$
- $\frac{A_s \text{ span}}{b \times d} \leq \frac{4,2}{f_e} \rightarrow \frac{6.03}{30 \times (0,9 \times 35)} \leq \frac{4,2}{f_e} \rightarrow 0,00638 \leq 0,0105 \dots\dots\dots CV$
- $\frac{h}{l} \geq \frac{1}{10} \left(\frac{M_{t \text{ ser}}}{M_0} \right) \rightarrow \frac{0.35}{5} \geq \frac{28.7211}{10 \times 62.79} \rightarrow 0,07 \geq 0,046 \dots\dots\dots CV$

So, the arrow verification is not necessary.

VI.2.3.6 Shema Reinforcement:

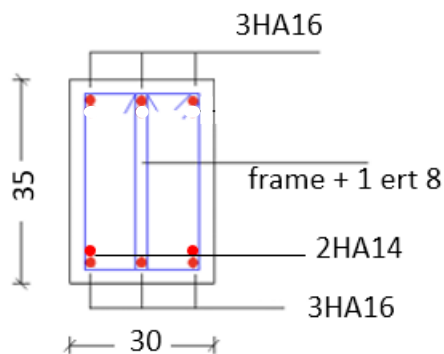

Figure VI.3 Reinforcement on support-Main beam-

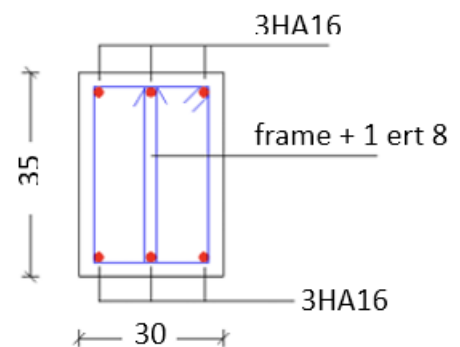

Figure VI.4 Reinforcement on span -Main beam

VI.2.4 Calculation of secondary beams: $(30 \times 35) \text{ cm}^2$

The beams are calculated in simple bending by considering the combinations above with:

ULS:

The Poisson's coefficient is: $\nu = 0$ for:
$$\begin{cases} 1.35G + 1.5Q \\ 0.8G \pm E \\ G + Q \pm E \end{cases}$$



Figure VI.5 The Poisson's coefficient at ULS

SLS:

The Poisson coefficient is: $\nu = 0.2$ for: $G+Q$

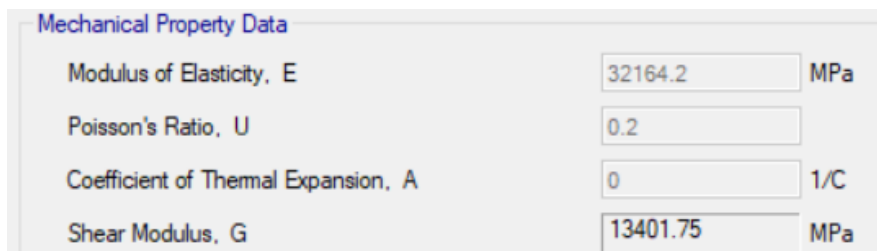

Figure VI.6 The Poisson's coefficient at SLS

The maximum stresses used From ETABS are:

Table VI.2 Maximum loads for secondary beams

Combination	M_{span} (KN.m)	M_{support} (KN.m)	V (KN.m)
ULS	42.6974	-62.8443	98.17
SLS	30.9137	-45.5737	71.245
$G + Q \pm E$	96.412	-93.8938	144.2308
$0.8G \pm E$	93.5545	-89.6821	133.8859

VI.2.4.1 Longitudinal reinforcements :**ULS :**

(h=35 cm, b= 30 cm, d=0.9×h= 31.5 cm, f_{bc} = 14.2 MPa, σ_s = 348 MPa)

On Span :

$M_{span} = 42.6974$ KN.m

$$\mu = \frac{M_{span}}{b \times d^2 \times f_{bc}}$$

$$\mu = \frac{42.6974 \times 10^{-3}}{0.30 \times 0.315^2 \times 14.2} = 0.101 < \mu_l = 0.391 \rightarrow A'_s = 0$$

$\mu = 0.101 < 0.186 \rightarrow$ Pivot A

$$\alpha_u = 1.25 \times (1 - \sqrt{1 - 2\mu})$$

$$\alpha_u = 1.25 \times (1 - \sqrt{1 - 2 \times 0.101}) = 0.133$$

$$\beta = 0.8 \times \alpha_u = 0.1064$$

$$A_s = \beta \times b \times d \times \frac{f_{bc}}{\sigma_s}$$

$$A_s = 0.1064 \times 0.3 \times 0.315 \times \frac{14.2}{348}$$

$$A_s = 4.1 \text{ cm}^2$$

On support :

$M_{support} = 62.8443$ KN.m

$$\mu = \frac{M_{span}}{b \times d^2 \times f_{bc}}$$

$$\mu = \frac{62.8443 \times 10^{-3}}{0.30 \times 0.315^2 \times 14.2} = 0.148 < \mu_l = 0.391 \rightarrow A'_s = 0$$

$\mu = 0.148 < 0.186 \rightarrow$ Pivot A

$$\alpha_u = 1.25 \times (1 - \sqrt{1 - 2\mu})$$

$$\alpha_u = 1.25 \times (1 - \sqrt{1 - 2 \times 0.148}) = 0.201$$

$$\beta = 0.8 \times \alpha_u = 0.1608$$

$$A_s = \beta \times b \times d \times \frac{f_{bc}}{\sigma_s}$$

$$A_s = 0.1608 \times 0.3 \times 0.315 \times \frac{14.2}{348}$$

$$A_s = 6.2 \text{ cm}^2$$

Calculation of reinforcement on the upper layer of the support :**G+Q+E**

(h=35 cm, b= 30 cm, d=0.9×h= 31.5 cm, f_{bc} = 18.48 MPa, σ_s = 400 MPa)

$$M_{\text{support}} = -93.8938 \text{ KN.m}$$

$$\mu = \frac{M_{\text{span}}}{b \times d^2 \times f_{bc}}$$

$$\mu = \frac{93.8938 \times 10^{-3}}{0.30 \times 0.315^2 \times 18.48} = 0.171 < \mu_l = 0.391 \rightarrow A'_s = 0$$

$$\mu = 0.171 < 0.186 \rightarrow \text{Pivot A}$$

$$\alpha_u = 1.25 \times (1 - \sqrt{1 - 2\mu})$$

$$\alpha_u = 1.25 \times (1 - \sqrt{1 - 2 \times 0.171}) = 0.236$$

$$\beta = 0.8 \times \alpha_u = 0.189$$

$$A_s = \beta \times b \times d \times \frac{f_{bc}}{\sigma_s}$$

$$A_s = 0.189 \times 0.3 \times 0.315 \times \frac{18.48}{400}$$

$$A_s = 8.24 \text{ cm}^2$$

Calculation of reinforcement on the lower layer of the support :**0.8G + E**

$$M_{\text{support}} = 89.6821 \text{ KN.m}$$

$$\mu = \frac{M_{\text{span}}}{b \times d^2 \times f_{bc}}$$

$$\mu = \frac{89.6821 \times 10^{-3}}{0.30 \times 0.315^2 \times 18.48} = 0.163 < \mu_l = 0.391 \rightarrow A'_s = 0$$

$$\mu = 0.163 < 0.186 \rightarrow \text{Pivot A}$$

$$\alpha_u = 1.25 \times (1 - \sqrt{1 - 2\mu})$$

$$\alpha_u = 1.25 \times (1 - \sqrt{1 - 2 \times 0.163}) = 0.223$$

$$\beta = 0.8 \times \alpha_u = 0.1784$$

$$A_s = \beta \times b \times d \times \frac{f_{bc}}{\sigma_s}$$

$$A_s = 0.1784 \times 0.3 \times 0.315 \times \frac{18.48}{400}$$

$$A_s = 7.79 \text{ cm}^2$$

VI.2.4.2 Verification required :**➤ Condition of non-fragility :(CBA93)**

$$A_{s \min} = \frac{0,23 \times b \times d \times f_{t28}}{f_e} = \frac{0,23 \times 0,3 \times (0,9 \times 0,35) \times 2,1}{400} = 1,14 \times 10^{-4} \text{ m}^2 = 1,14 \text{ cm}^2$$

So: $A_{s \min} = 1,14 \text{ cm}^2$

➤ Minimum section of steels (RPA99V2003) :

$$A_{s \min \text{ RPA}} = 0,5\% \mathbf{b} \times \mathbf{h}$$

$$A_{s \min \text{ RPA}} = \frac{0,5}{100} \times 30 \times 35 = 5.25 \text{ cm}^2$$

So:

On span:

$$A_s = \max (A_s, A_{s \min}, A_{s \min \text{ RPA}}) = \max (4.1; 1.14; 5.25) = 5.25 \text{ cm}^2$$

So, we take:

$$A_{s \text{ span}} = 3\text{HA}16 = 6,03 \text{ cm}^2$$

Reinforcement on upper layer supports :

$$A_s = \max (A_s, A_{s \min}, A_{s \min \text{ RPA}}) = \max (8.24; 1.14; 5.25) = 8.24 \text{ cm}^2$$

So, we take:

$$A_{s \text{ sup}} = 3\text{HA}16 + 2\text{HA}14 = 9,11 \text{ cm}^2$$

Reinforcement on lower layer supports :

$$A_s = \max (A_s, A_{s \min}, A_{s \min \text{ RPA}}) = \max (7.79; 1.14 ; 5.25) = 7.79 \text{ cm}^2$$

So, we take:

$$A_{s \text{ sup}} = 3\text{HA}16 + 2\text{HA}14 = 9,11 \text{ cm}^2$$

➤ The maximum percentage of steels (RPA99/2003 a.7.5.2.1)

$$A_s \leq A_{s \text{ Max}}$$

$$A_{s \text{ Max}} = 0.04 \times b \times h \rightarrow \text{In the current zone.}$$

$$A_{s \text{ Max}} = 0.06 \times b \times h \rightarrow \text{In the overlap area.}$$

→ **In the current zone :**

$$A_{s \text{ Max}} = 0.04 \times 30 \times 35$$

$$A_{s \text{ Max}} = 42 \text{ cm}^2 \geq A_{s \text{ sup}} = 9.11 \text{ cm}^2 \rightarrow \text{CV}$$

$$A_{s \text{ Max}} = 42 \text{ cm}^2 \geq A_{s \text{ span}} = 6.03 \text{ cm}^2 \rightarrow \text{CV}$$

→ **In the overlap area :**

$$A_{s \text{ Max}} = 0.06 \times 30 \times 35$$

$$A_{s \text{ Max}} = 63 \text{ cm}^2$$

$$A_{s \text{ Max}} = 63 \text{ cm}^2 \geq A_{s \text{ sup}} = 9.11 \text{ cm}^2 \rightarrow \text{CV}$$

$$A_{s \text{ Max}} = 63 \text{ cm}^2 \geq A_{s \text{ span}} = 6.03 \text{ cm}^2 \rightarrow \text{CV}$$

➤ **The minimum overlap length :**

In (Zone IIa)

$$L = 40 \times \emptyset$$

$$L1 = 40 \times 1.6 = 64 \text{ cm}$$

$$L2 = 40 \times 1.4 = 56 \text{ cm.}$$

➤ **Nodal zone length**

$$L' = 2 \times h = 70 \text{ cm}$$

VI.2.4.3 Transverse reinforcements :

$$\emptyset_{\text{tr}} \leq \min \left\{ \frac{h}{35}; \emptyset_1; \frac{b}{10} \right\}$$

$$\emptyset_{\text{tr}} \leq \min \left\{ \frac{350}{35}; 16; \frac{300}{10} \right\} = \min \{10; 16; 30\} = 10 \text{ mm}$$

We take:

$$\emptyset_{\text{tr}} = 8 \text{ mm.}$$

Calculation of spacing :

CBA

$$S_t \leq \min (0.9d ; 40) = \min (31.5; 40)$$

$$S_t = 20 \text{ cm}$$

(RPA)

In the nodal zone :

$$S_t \leq \min (h/4; 12 \times \emptyset_1) = \min (8.75; 19.2) = 8.75 \text{ cm}$$

$$S_t = 8 \text{ cm.}$$

Outside the nodal zone :

$$S_t \leq \frac{h}{2}$$

$$S_t \leq \frac{35}{2}$$

$$S_t = 17.5 \text{ cm}$$

We choose: $S_t = 15 \text{ cm}$

Minimum cross-section of transverse steels :

$$A_t = 0.003 \times S_t \times b$$

In the nodal zone :

$$A_t = 0.003 \times 8 \times 30 = 0.72 \text{ cm}^2$$

Outside the nodal zone :

$$A_t = 0.003 \times 15 \times 30 = 1.35 \text{ cm}^2$$

For the both zones: $A_s = 4T8 = 2.01 \text{ cm}^2$

VI.2.4.4 Verification of shear force : (C.B.A 93 A.5.1.2.1)

$$\tau_u \leq \bar{\tau}_u$$

Minimally harmful cracking so:

$$\bar{\tau}_u = (0.2 \times \frac{f_{cj}}{\gamma_b}; 5 \text{ MPa})$$

$$\bar{\tau}_u = 3.33 \text{ MPa.}$$

$$\tau_u = \frac{V}{b \times d}$$

$$\tau_u = \frac{98.17 \times 10^{-3}}{0.3 \times 0.315} = 1.04 \text{ MPa} \leq \bar{\tau}_u \dots\dots\dots \text{CV}$$

VI.2.4.5 Service limit status check :

- As cracking is not harmful (little-harmful)CV
- The steel used is of grade FeE400.....CV
- The section is rectangular (30x35) CV
- Simple bending.....CV

As the condition below is verified, stress limitation in concrete will be unnecessary.
It must be verified that:

$$\alpha < \frac{\gamma-1}{2} + \frac{f_c 28}{100}$$

$$\text{With: } \gamma = \frac{M_u}{M_{ser}}$$

On span :

$$\alpha = 0.133$$

$$\alpha < \frac{\gamma-1}{2} + \frac{f_c 28}{100}$$

$$\gamma = \frac{42.6974}{30.9137} = 1.38$$

$$\alpha = 0.133 < \frac{1.38-1}{2} + \frac{25}{100} = 0.44 \dots\dots\dots \text{CV}$$

On the upper layer of the support :

$$\alpha=0.236$$

$$\alpha < \frac{\gamma-1}{2} + \frac{f_c 28}{100}$$

$$\gamma = \frac{93.8938}{45.5737} = 2.06$$

$$\alpha = 0.236 < \frac{2.06-1}{2} + \frac{25}{100} = 0.78 \dots \dots \dots CV$$

On the lower layer of the support :

$$\alpha=0.223$$

$$\alpha < \frac{\gamma-1}{2} + \frac{f_c 28}{100}$$

$$\gamma = \frac{89.6821}{45.5737} = 1.98$$

$$\alpha = 0.223 < \frac{1.98-1}{2} + \frac{25}{100} = 0.74 \dots \dots \dots CV$$

All conditions are verified so there is not verification at SLS.

Arrow verification :

It is not necessary to check the arrow of the three condition listed below are verified simultaneously.

- $\frac{h}{L} \geq \frac{1}{16} \rightarrow \frac{0.35}{4.9} = 0.071 \geq \frac{1}{16} = 0.0625 \dots \dots \dots CV$
- $\frac{A_s \text{ span}}{b \times d} \leq \frac{4,2}{f_e} \rightarrow \frac{4.1}{30 \times (0,9 \times 35)} \leq \frac{4,2}{f_e} \rightarrow 0,0043 \leq 0,0105 \dots \dots \dots CV$
- $\frac{h}{l} \geq \frac{1}{15} \left(\frac{M_{t \text{ ser}}}{M_0} \right) \rightarrow \frac{0.35}{4.9} \geq \frac{30.9137}{14.02} \rightarrow 0,071 \geq 0,053 \dots \dots \dots CV$

So, the arrow verification is not necessary.

VI.2.4.6 Shema Reinforcement :

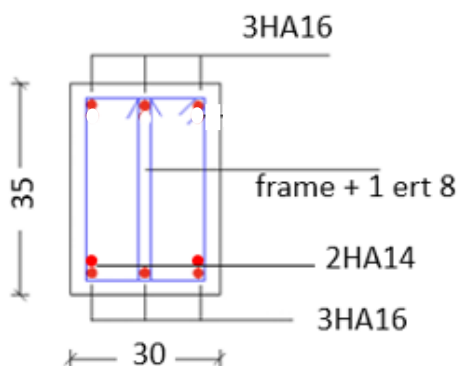

Figure VI.7 Reinforcement on support

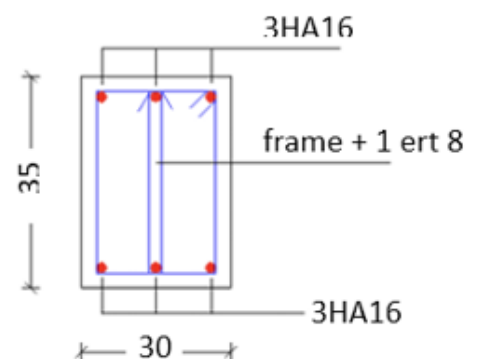

Figure VI.8 Reinforcement on span

VI.3 Reinforcements of the columns :

Columns are vertical structural element that transmits, through compression, the weight of the structure above to other structural elements below. Columns are typically cylindrical in shape, though they can also be square, rectangular, or other geometric shapes. They serve to support the load-bearing capacity of a building or structure and are often arranged in rows or groups to form colonnades or other architectural features.

The reinforcement of the columns is calculated in compound bending as a function of the normal force (N) and of the bending moment (M) in both directions, given by the most unfavorable combinations.

VI.3.1 Combination of loads :

- Combinations given by the **CBA93 art 6.1.2:**

$$\begin{cases} \text{ULS} = 1.35 G + 1.5 Q \\ \text{SLS} = G + Q \end{cases}$$

- Combinations given by the **RPA99V2003:**

$$\begin{cases} 0.8 G \pm E \\ G + Q \pm E \end{cases}$$

The steel section will be calculated for different combinations of internal forces:

$$N_{\max} \Rightarrow M_{\text{correspondant}}$$

$$N_{\min} \Rightarrow M_{\text{correspondant}}$$

$$M_{\max} \Rightarrow N_{\text{correspondant}}$$

With:

N_{\max} : maximum normal effort

N_{\min} : minimum normal effort

N_{\max} : maximum moment

VI.3.2 Various regulatory recommendation and requirements for columns :**VI.3.2.1 Longitudinal reinforcements : (RPA99V2003 art.7.4.2.1)**

Longitudinal reinforcements must be high adhesion, straight and devoid of brackets:

- The minimum percentage is: 0.8 % (Zone IIa).
- The maximum percentage and 4% in running area.
- The maximum percentage and 6% in covering area.
- The minimum diameter is 12mm.
- The minimum overlap length is $40 \times \emptyset$ (zone IIa).
- The distance between the vertical bars in one face of the post must not exceed 25cm.
- Overlay junctions should be made, if possible, outside nodal areas (critical areas).

VI.3.2.2 Transverse reinforcements : (RPA99V2003 art 7.4.2.2)

- ✓ The transverse reinforcements of the columns are calculated using the formula:

$$\frac{A_t}{t} = \frac{\rho_a V_u}{h f_e}$$

- V_u : Is the shear effort of calculation.
- h : Total height of gross section.
- f_e : Yield stress of transverse reinforcing steel.
- ρ_a : Is a correction coefficient that takes into account the brittle mode of fracture by sharp force.

It is taken equal to 2,50 if the geometric slenderness λ_g in the direction considered, and is greater than or equal to 5 and 3,75 otherwise.

- t : is the spacing of transverse reinforcements.

VI.3.3 Solicitations in the column :

Calculation of Solicitations according to the worst combinations are extracted directly of the ETABS22 software, and the results are summarized in the following tables for each column:

VI.3.3.1 Column (40×40) :

Table IV.3 Solicitations in the column 40×40 from Etabs2022

comb	N ⁰	N _{max}	N _{min}	M _{cor}	M	N _{cor}	T	N _{ser}	M _{ser}
ULS	1	-1446.4604		-0.195			50.2287	-1053.4	-0.4281
	2		-14.246	0.411				-34.83	23.12
	3				-29.464	-146.725		-107.6	9.54
0.8 G+Q	4	-1531.1187		-46.514			-105.4449	-336.307	33.8216
	5		1089.368	20.850				-252.9	36.5
	6				-52.935	-502.488		-430.2	-49.44
G+Q+E	7	-1617.7822		-48.005			-109.9161	-423.1	36.03
	8		1036.414	21.06				-333.774	37.12
	9				-56.828	-676.888		-604.655	51.23

Calculation of longitudinal reinforcements :

$$h = 0.40\text{m}; b = 0.40 \text{ m}; d = 0.9 \times h = 0.36 \text{ m}; L = 3.06 \text{ m}$$

❖ ULS :**Cas n° 1:**

$$\begin{cases} N_{\max} = -1446.4604 \text{ KN} \\ M_{\text{corr}} = -0.195 \text{ KN.m} \\ M_{\text{ser}} = -0.4281 \text{ KN.m} \end{cases}$$

Calculation of eccentricity : CBA93

$$e = e_1 + e_2 + e_a$$

With:

$$e_1 = \frac{M_u}{N_u}$$

$$e_a = \max \left\{ 2\text{cm}; \frac{L}{250} \right\}$$

$$e_2 = \frac{3L_f^2}{10000h} (2 + \alpha\phi)$$

$$L_f = 0.7L = 0.7 \times 3.06 = 2.142 \text{ m}$$

$$\alpha = 10 \times \left(1 - \frac{M_u}{1.5 \times M_{\text{ser}}} \right) = 10 \times \left(1 - \frac{0.195}{1.5 \times 0.4281} \right) = 6.96$$

$$e_1 = \frac{M_u}{N_u} = \frac{0.195}{1446.4604} = 0.013 \text{ cm}$$

$$e_a = \max \left\{ 2\text{cm}; \frac{306}{250} \right\} = \max \{ 2\text{cm}; 1.224 \text{ cm} \} \Rightarrow e_a = 2 \text{ cm}$$

$$e_2 = \frac{3L_f^2}{10000h} (2 + \alpha\phi) \text{ with } \phi = 2$$

$$e_2 = \frac{3 \times 2.14^2}{10000 \times 0.40} (2 + 6.96 \times 2) = 0.10 \text{ cm}$$

So:

$$e = 0.013 + 0.10 + 2 = 2.112 \text{ cm}$$

Calculation of the maximum centered compressive force supported by the concrete :**Refill coefficient ψ :**

$$\psi = \frac{N_u}{b \times h \times f_{bc}} = \frac{1446.4604 \times 10^{-3}}{0.40 \times 0.40 \times 14.2} = 0.637 < 0.81$$

And we calculate the relative eccentricity e_{NC} :

$$e_{NC} = \xi \times h$$

$$\psi \leq \frac{2}{3}$$

$$\xi = \frac{1 + \sqrt{9 - 12\psi}}{4 \times (3 + \sqrt{9 - 12\psi})} = \frac{1 + \sqrt{9 - 12 \times 0.637}}{4 \times (3 + \sqrt{9 - 12 \times 0.637})} = 0.129$$

$$e_{NC} = \xi \times h = 0.13 \times 0.40 = 0.052 \text{ m} = 5.2 \text{ cm}$$

So:

$$e = 0.0211 \leq e_{NC} = 0.052 \text{ m}$$

So, the section is entirely compressed, does not reach the minimum reinforcement percentage.

$A = (4 \times \text{The perimeter}; 0.2\% \leq A/B \leq 5\%)$

$$A = 4 \times 0.40 \times 4 = 6.4 \text{ cm}^2$$

$$0.2\% \leq \frac{6.4}{1600} = 0.004 = 0.4\% \leq 5\% \dots\dots\dots \text{CV}$$

So:

$$A_s = 6.4 \text{ cm}^2$$

Cas n° 2:

$$\begin{cases} N_{\max} = -14.246 \text{ KN} \\ M_{\text{corr}} = 0.411 \text{ KN.m} \\ M_{\text{ser}} = 23.12 \text{ KN.m} \end{cases}$$

Calculation of eccentricity : CBA93

$$e = e_1 + e_2 + e_a$$

With:

$$e_1 = \frac{M_u}{N_u}$$

$$L_f = 0.7L = 0.7 \times 3.06 = 2.142 \text{ m}$$

$$\alpha = 10 \times \left(1 - \frac{M_u}{1.5 \times M_{\text{ser}}}\right) = 10 \times \left(1 - \frac{0.411}{1.5 \times 23.12}\right) = 9.88$$

$$e_1 = \frac{M_u}{N_u} = \frac{0.411}{14.246} = 2.885 \text{ cm}$$

$$e_a = \max\left\{2 \text{ cm}; \frac{306}{250}\right\} = \max\{2 \text{ cm}; 1.224 \text{ cm}\} \Rightarrow e_a = 2 \text{ cm}$$

$$e_2 = \frac{3L_f^2}{10000h} (2 + \alpha\emptyset) \text{ with } \emptyset = 2$$

$$e_2 = \frac{3 \times 2.14^2}{10000 \times 0.40} (2 + 9.88 \times 2) = 7.47 \text{ cm}$$

So:

$$e = e_1 + e_2 + e_a = 12.355 \text{ cm}$$

Calculation of the maximum centered compressive force supported by the concrete :

Refill coefficient ψ :

$$\psi = \frac{N_u}{b \times h \times f_{bc}} = \frac{14.246 \times 10^{-3}}{0,40 \times 0,40 \times 14,2} = 0.0062 < 0,81$$

And we calculate the relative eccentricity e_{NC} :

$$e_{NC} = \xi \times h$$

$$\psi \leq \frac{2}{3}$$

$$\xi = \frac{1 + \sqrt{9 - 12\psi}}{4 \times (3 + \sqrt{9 - 12\psi})} = \frac{1 + \sqrt{9 - 12 \times 0.0062}}{4 \times (3 + \sqrt{9 - 12 \times 0.0062})} = 0.166$$

$$e_{NC} = \xi \times h = 0.166 \times 0.40 = 0.0664 \text{ m}$$

So:

$$e = 12.355 \text{ cm} \leq e_{NC} = 6.64 \text{ cm} \dots\dots\dots \text{CNV}$$

So, the section is partially compressed.

The fictional moment:

$$M_{fictif} = M_u + N_u \times \left((d+e) - \frac{h}{2} \right)$$

$$M_{fictif} = 14.246 \times \left((0.36 + 0.1235) - \frac{0.40}{2} \right) = 4.04 \text{ KN.m}$$

One calculated the reinforcement of section subjected to simple bending under M_{fictif}

So:

$$\mu = \frac{M_{fictif}}{b \times d^2 \times f_{bc}}$$

$$\mu = \frac{4.04 \times 10^{-3}}{0.40 \times 0.36^2 \times 14.2} = 0.0054 < 0.186 \rightarrow \text{Pivot A}$$

$$\alpha_u = 1.25 \times (1 - \sqrt{1 - 2\mu})$$

$$\alpha_u = 1.25 \times (1 - \sqrt{1 - 2 \times 0.0054}) = 0.0067$$

$$\beta = 0.8 \times \alpha_u = 0.0053$$

$$A_{s \text{ fictif}} = \beta \times b \times d \times \frac{f_{bc}}{\sigma_s}$$

$$A_{s \text{ fictif}} = 0.0053 \times 0.40 \times 0.36 \times \frac{14.2}{348} = 3.11 \text{ cm}^2$$

So:

$$A_s = A_{s \text{ fictif}} - \frac{N_u}{\sigma_{su}} = 3.20 - \frac{14.246 \times 10^{-3}}{348} = 3.10 \text{ cm}^2$$

$$\text{So: } A_s = 3.10 \text{ cm}^2$$

Cas n° 3:

$$\begin{cases} N_{\max} = -146.725 \text{ KN} \\ M_{\text{corr}} = -29.464 \text{ KN.m} \\ M_{\text{ser}} = 9.54 \text{ KN.m} \end{cases}$$

Calculation of eccentricity : CBA93

$$\alpha = 10 \times \left(1 - \frac{M_u}{1.5 \times M_{\text{ser}}}\right) = 10 \times \left(1 - \frac{29.464}{1.5 \times 9.54}\right) = 30.5$$

$$e_1 = \frac{M_u}{N_u} = \frac{29.464}{146.725} = 0.2008 \text{ m} = 20.08 \text{ cm}$$

$$e_a = \max\left\{2 \text{ cm}; \frac{306}{250}\right\} = \max\{2 \text{ cm}; 1.224 \text{ cm}\} \Rightarrow e_a = 2 \text{ cm}$$

$$e_2 = \frac{3 \times 2.14^2}{10000 \times 0.40} (2 - 30.5 \times 2) = -0.2026 \text{ m} = -20.26 \text{ cm}$$

So:

$$e = 20.08 + 2 - 20.26 = 1.82 \text{ cm}$$

Calculation of the maximum centered compressive force supported by the concrete:**Refill coefficient ψ :**

$$\psi = \frac{N_u}{b \times h \times f_{bc}} = \frac{146.725 \times 10^{-3}}{0.40 \times 0.40 \times 14.2} = 0.064 < 0.81$$

And we calculate the relative eccentricity e_{NC} :

$$e_{NC} = \xi \times h$$

$$\psi \leq \frac{2}{3}$$

$$\xi = \frac{1 + \sqrt{9 - 12\psi}}{4 \times (3 + \sqrt{9 - 12\psi})} = \frac{1 + \sqrt{9 - 12 \times 0.064}}{4 \times (3 + \sqrt{9 - 12 \times 0.064})} = 0.165$$

$$e_{NC} = \xi \times h = 0.165 \times 0.40 = 0.066 = 6.6 \text{ cm}$$

So:

$$e = 1.82 \text{ cm} \leq e_{NC} = 6.6 \text{ cm} \dots\dots\dots \text{CV}$$

So, the section is entirely compressed, does not reach the minimum reinforcement percentage.

$$A = (4 \times \text{The perimeter}; 0.2\% \leq A/B \leq 5\%)$$

$$A = 4 \times 0.40 \times 4 = 6.4 \text{ cm}^2$$

$$0.2\% \leq \frac{6.4}{1600} = 0.004 = 0.4\% \leq 5\% \dots\dots\dots \text{CV}$$

So:

$$A_s = 6.4 \text{ cm}^2$$

The other accidental cases are summarized in the following tables:

Table IV.4 The other accidental cases of column 45×45

Comb	N	e_1	e_a	e_2	e	ψ	ξ	e_{NC}	section
ULS	1	0.013	2	0.10	2.112	0.637	0.129	5.2	Entirely compressed
	2	2.885	2	7.47	12.355	0.0062	0.166	6.64	partially compressed
	3	20.08	2	-20.26	1.82	0.064	0.165	6.6	Entirely compressed
G + Q ± E	4	3.03	2	1.25	6.28	0.673	0.124	4.96	Partially compressed
	5	2.18	2	0.43	4.61	0.25	0.158	7.11	Entirely compressed
	6	98	2	2.23	102.23	0.0205	0.166	7.47	Partially compressed
0.8G ± E	7	2.14	2	-5.86	-1.72	0.527	0.14	6.3	Entirely compressed
	8	1.17	2	2.9	6.07	0.2797	0.16	7.2	Entirely compressed
	9	91.95	2	1.89	95.14	0.016	0.166	7.84	Entirely compressed

Table VI.5 Reinforcement section of columns 45×45

Comb	N	M_{fictif}	μ		α_u	β	A_s fictif	A_s
ULS	1	/	/		/	/	/	6.4
	2	44.04	0.0054		0.054	0.053	3.11	3.10
	3	/	/		/	/	/	6.4
0.8G ± E	4	341.133	0.463		0.17	0.044	2.585	2.58
	5	/	/		/	/	/	7.2
	6	14.98	0.02		0.063	0.045	2.644	2.64
G+Q+E	7	/	/		/	/	/	7.2
	8	/	/		/	/	/	7.2
	9	/	/		/	/	/	1.05

VI.3.4 Verification required :➤ **Condition of non-fragility :(CBA93)**

$$A_s \geq A_{s \min}$$

$$A_{s \min} = \frac{0,23 \times b \times d \times f_{t28}}{f_e} = \frac{0,23 \times 0,40 \times 0,36 \times 2,1}{400} = 1.74 \text{ cm}^2$$

$$A_s = 6.4 \text{ cm}^2 \geq 2.2 \text{ cm}^2$$

➤ **Minimum section of steels (RPA99V2003 art .7.4.2.1):**

$$A_{s \min \text{ RPA}} = 0,8\% \text{ b} \times \text{h}$$

$$A_{s \min \text{ RPA}} = \frac{0,8}{100} \times 40 \times 40 = 12.8 \text{ cm}^2$$

$$\text{So: } A_{s \min} = 12.8 \text{ cm}^2$$

$$A_{s \min} = 12.8 \text{ cm}^2 \geq A_s = 6.4 \text{ cm}^2$$

$$\text{So: } A_s = 12.8 \text{ cm}^2$$

$$\text{We take: } A_s = 4\emptyset 16 + 4\emptyset 14 = 14.19 \text{ cm}^2$$

➤ **Maximum percentage of longitudinal steels :**

In running area :

$$A_{s \max} \geq A_s$$

$$A_{s \max} = 4\% \times b \times h = \frac{4}{100} \times 40 \times 40$$

$$\Rightarrow A_{s \max} = 64 \text{ cm}^2$$

$$A_{s \max} = 64 \text{ cm}^2 \geq A_s = 17.09 \text{ cm}^2 \dots\dots\dots \text{CV}$$

In covering area:

$$A_{s \max} \geq A_s$$

$$A_{s \max \text{ RPA}} = 6\% \times b \times h = \frac{6}{100} \times 40 \times 40$$

$$\Rightarrow A_{s \max \text{ RPA}} = 96 \text{ cm}^2$$

$$A_{s \max} = 96 \text{ cm}^2 \geq A_s = 17.09 \text{ cm}^2 \dots\dots\dots \text{CV}$$

The minimum diameter :

$$\emptyset_{\min} = 12 \text{ mm} \geq 12 \text{ mm} \dots\dots\dots \text{CV}$$

The minimum lap length for zone IIa is :

$$L_{\text{lap}} = 40\emptyset = 40 \times 12 = 480 \text{ mm}$$

- The maximum distance between two vertical bars in one side of the column must not exceed 25 cm.

Verification of SLS

- The concrete stress:

$$\sigma_{bc} \leq \overline{\sigma}_{bc}$$

With: $\overline{\sigma}_{bc} = 0.6f_{c28} = 15 \text{ MPa}$

- The steel stress:

$$\sigma_s \leq \overline{\sigma}_s$$

With:

$$\overline{\sigma}_s = \min\left\{\frac{2}{3} \times f_e ; 110\sqrt{1.6 \times f_{tj}}\right\} = \min\left\{\frac{2}{3} \times 400 ; 110\sqrt{1.6 \times 2.1}\right\}$$

$$\Rightarrow \overline{\sigma}_s = 201.6 \text{ MPa}$$

Calculation of the position of the neutral axis :

$$e = \frac{M_{ser}}{N_{ser}} = \frac{51.23}{-604.655} = -0.08 \text{ m}$$

We compared with $\frac{h}{4}$ to know the type of section

$$\frac{h}{4} = \frac{0.40}{4} = 0.1 \text{ m} > e = -0.08 \text{ m}$$

So, the section is Entirely compressed then, there is to check that the concrete compression condition.

- **The area of the homogeneous section :**

$$S = b \times h + 15 \times (A_s + A'_s)$$

$$S = b \times h + 15 \times (A_s + A'_s) = 0.40 \times 0.40 + 15 \times (17.09 \times 10^{-4}) = 0.1856 \text{ m}^2 = 1856 \text{ cm}^2$$

- **The position of the center of gravity :**

$$x_G = \frac{A'_s \left(\frac{h}{2} - d'\right) - A_s \left(d - \frac{h}{2}\right)}{b \times h + 15 \times (A_s + A'_s)}$$

$$x_G = \frac{-17.09 \times 10^{-4} (0.36 - 0.2)}{0.1856} = -0.00147 \text{ m}$$

- **Calculation the moment if inertia :**

$$I = \frac{b \times h^3}{3} + b \times h \times x_G^2 + 15 \times \left[A_s \cdot \left(d - \frac{h}{2} + x_G \right)^2 \right]$$

$$I = \frac{0.40 \times 0.40^3}{3} + 0.40 \times 0.40 \times 0.00147^2 + 15 \left[17.09 \times 10^{-4} \times \left(0.36 - \frac{0.4}{2} - 0.00147 \right)^2 \right]$$

$$I = 2.77 \times 10^{-3} \text{ m}^4$$

VI.3.5 Transversal reinforcement :

$$\lambda_g = \frac{L_f}{b}$$

$$\lambda_g = \frac{2,142}{0,40} = 5.35 > 5 \Rightarrow \rho_a = 2.5$$

Spacing between the reinforcement in the nodal zone :

$$t \leq \min\{10\phi_l; 15\text{cm}\} = \min\{10 \times 2; 15\text{cm}\} = 15\text{cm}$$

So, $t = 10\text{cm}$

Spacing between the reinforcement current zone :

$$t' \leq \text{Min} \left(\frac{b}{2}; \frac{h}{2}; 10\phi \right) = t' \leq 10 \times 2 = 20 \text{ cm}$$

$t' = 15 \text{ cm}$

Quantity of reinforcement :

$$\frac{A_t}{t} = \frac{\rho_a V_u}{h f_e}$$

In the nodal zone:

$$A_t = \frac{\rho_a V_u}{h f_e} \times t = \frac{2.5 \times 50.2287 \times 10^{-3} \times 0.1}{0.40 \times 400} = 0.78 \text{ cm}^2$$

In the current zone:

$$A_t = \frac{\rho_a V_u}{h f_e} \times t' = \frac{2.5 \times 50.2287 \times 10^{-3} \times 0.15}{0.40 \times 400} = 1.18 \text{ cm}^2$$

Minimum section of the transverse reinforcement :

$$A_{t \min} = (0.3\% \times t \times b)$$

In nodal zone:

$$A_{t \min} = 0.3\% \times t \times b = 0.3\% \times 10 \times 40 = 1.2 \text{ cm}^2$$

In current zone:

$$A_{t \min} = 0.3\% \times t \times b = 0.3\% \times 15 \times 40 = 1.8 \text{ cm}^2$$

We chose 4T8 = 2.01 cm²

VI.3.6 Verification the shear force :(CBA93 art 5.1.2.1)

We must check:

$$\tau_u \leq \bar{\tau}_u$$

$$\bar{\tau}_u = (0.2 \times \frac{f_{cj}}{\gamma_b}; 5 \text{ MPa}) = (0.2 \times \frac{25}{1.5}; 5 \text{ MPa}) = 3.33 \text{ MPa}$$

$$\tau_u = \frac{V}{b \times d}$$

$$\tau_u = \frac{50.2287 \times 10^{-3}}{0.40 \times 0.36} = 0.35 \text{ MPa} \leq \bar{\tau}_u \dots\dots\dots \text{CV}$$

Buckling verification :

We must check the following formula : $\lambda \leq 50$

$$\lambda = \frac{L_f}{i}$$

$$i = \sqrt{\frac{I}{B}}$$

$$I = \frac{b \times h^3}{12}$$

$$i = \sqrt{\frac{I}{B}} = \sqrt{\frac{2.77 \times 10^{-3}}{0.16}} = 0,13$$

$$\lambda = \frac{L_f}{i} = \frac{2.14}{0,13} = 16.46 \leq 50 \dots\dots\dots \text{CV}$$

VI.3.7 Shema Reinforcement :

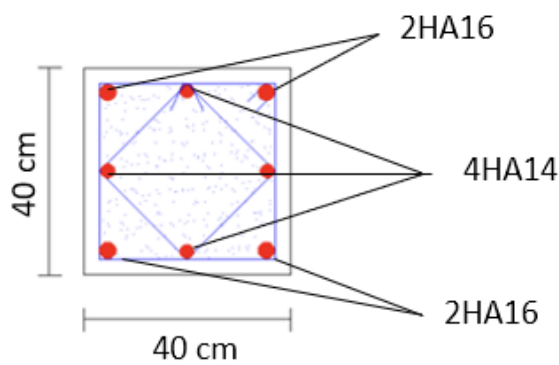

Figure IV.9 Reinforcement of the column

VI.4 Reinforcements of the walls :**VI.4.1 Introduction :**

Walls are bracing elements specially designed to resist lateral forces, such as those caused by wind or seismic activity. They are often strategically placed throughout a building to enhance its overall structural stability.

The reinforcement of the walls will be carried out in accordance with the BAEL91 regulation and the verification according to the Algerian seismic regulation RPA99/version 2003.

The reinforcement of the walls consists of determining the arrangements of the reinforcement which are:

- Vertical reinforcement.
- Horizontal reinforcement.
- Transverse reinforcements.

VI.4.2 Combination :

$$\left\{ \begin{array}{l} 1.35G + 1.5Q \\ G + Q \\ 0.8G \pm E \\ G + Q \pm E \end{array} \right.$$

VI.4.3 Calculation principle :**Wall mesh :**

Before start the calculation of solicitation we must do the mesh walls by ETABS 22.

The first thing we should do is a convergence study, which includes multiple tests with different sized elements. We then select a point on top of the building and compare the displacement between them in each test.

When the difference between the last and the previous tests reach a non-significant value, the mesh before the last one is retained to calculate the solicitations.

The mesh with the size 0.25 m is considered.

VI.4.4 Calculation method :

We have two methods for the calculation of the reinforcement of walls:

➤ Simplified method :

The dimensioning of the sails according to this method is carried out from the diagram of stresses generated by loads applied to sails.

The principle is based on the linear distribution of stresses due to vertical loads and moments, the stress diagram is divided into bands for which the average stress (for the compressed part) and the maximum stress (for the tensioned part) are taken for the calculation of the reinforcement.

➤ **Compound bending method**

Following this method, and as the veil works in its plan, the sizing of the wall is based on the principle of considering the wall as a reinforced concrete section subjected to bending with compression, admitting the parabolic-linear distribution of compressive stresses in the section.

- **We will use the stress method**

$$\sigma_{1,2} = \frac{N}{A} \pm \frac{M}{I} Y$$

With:

N: normal effort applied.

M: bending moment applied.

A: the section of the wall

Y distance between the centre of gravity of the wall and the farthest vibration

I: moment of inertia.

There are 3 cases :

1st case:

If: $(\sigma_1 \text{ and } \sigma_2) \gg 0$ The section of the wall is fully compressed "no zone tense".

The current area is armed with the minimum required by the RPA99 (version 2003)

$$A_{min} = 0,15 \times a \times L$$

2nd case:

If: $(\sigma_1 \text{ and } \sigma_2) \ll 0$ The section of the wall is fully stretched " no compressed zone ".

The volume of tensile stresses is calculated, hence the cross-section of the vertical reinforcements.

$$A_v = F_t / f_e$$

we compare A_v by the minimum section required by the RPA99 v2003

- If $A_v < A_{min} = 0,15 \times a \times L$. We scrap with the minimum cross-section.
- If $A_v > A_{min}$ On scrap with A_v .

3rd case:

If: $(\sigma_1 \text{ and } \sigma_2) = 0$ is of different sign, the section of the wall is partially compressed, so we calculate the volume of stresses the tense zone.

➤ **Vertical reinforcements :**

They are arranged on two parallel layers used to meet the bending stresses, the R.P.A99 (2003 version) requires a minimum percentage equal to 0.15% of the section of concrete.

The reinforcement will be arranged symmetrically in the sail due to the change of direction of earthquake with the diameter of the bars which must not exceed 1/10 of the thickness of the wall.

➤ **Horizontal reinforcements :**

Horizontal reinforcements parallel to the faces of the wall are distributed uniformly over the entire length of the wall or wall element limited by openings, horizontal bars must be arranged outwards.

The minimum percentage of horizontal reinforcements given as follows:

Overall in the wall section 0.15%.

In current zone 0.10%.

➤ **Transverse reinforcements :**

Transverse reinforcements perpendicular to the faces of the wall shall be provided with a density of at least 4/m², where the vertical reinforcements have a diameter less than or equal to 12 mm.

The transverse reinforcements must hold all bars with a spacing not more than 15 times the diameter of the vertical steels.

The transverse reinforcements may be pins with a diameter of 6 mm when the longitudinal bars have a diameter less than or equal to 20 mm, and 8 mm otherwise.

VI.4.5 Walls reinforcement :

The different solicitations are obtained from ETABS software:

Table IV.6 The different solicitations of wall

Comb	N (KN)	M (KN.m)	V(KN)
0.8G+E_x	1090.7437	565.47	-157.8
0.8G-E_x	1095.38	607.86	
0.8G+E_y	921.589	2377.7462	-345.596
0.8G-E_y	927.8062	2921.1973	
G+Q+E_x	1402.8772	632.4821	-205.744
G+Q-E_x	1419.2854	694.8336	
G+Q+E_y	1244.6463	2792.028	-380.325
G+Q-E_y	1248.7767	3149.0654	

$$N_{max} = 1419.2854 \rightarrow M_{coord} = 694.8336, V = -205.744$$

$$N_{min} = 921.589 \rightarrow M_{coord} = 2377.7462, V = -345.596$$

$$M_{max} = 3149.0654 \rightarrow N_{coord} = 1248.7767, V = -380.325$$

➤ **Example calculation :**

We took the wall at the level of the ground floor: rectangular wall with two columns at the ends (40×40) cm², with the following characteristics:

Length: 5 m

Thickness: 0.15 m

Section: $A = (4.51) \times 0.15 = 0.75 \text{ m}^2$

Moment of inertia:

$$I = \frac{e \times d^3}{12} = \frac{0.15 \times 5^3}{12} = 1.5625 \text{ m}^4$$

$$y = \frac{L}{2} = \frac{5}{2} = 2.5 \text{ m}$$

Y: The distance between the center of gravity of the wall and the furthest fiber.

Checking the resistance of the wall under the combination G+Q±E

Buckling verification :

For reinforced concrete case:

$$\lambda = \frac{L_f \sqrt{12}}{e} = \frac{2.601 \sqrt{12}}{0.15} = 60.06 \leq 80$$

Coefficient α :

$$50 < \lambda \leq 80$$

$$\alpha = 0.6(50/\lambda)^2 = \alpha = 0.6(50/60.06)^2 = 0.4158$$

Reduced section:

$$Br = L \times (e - 0, 02) = 5 \times (0, 15 - 0, 02) = 0.65 \text{ m}^2$$

Minimum section of steels

$$A_{S \min} = 0,23 \times A \times \frac{f_{t28}}{f_e} = 9.05 \text{ cm}^2$$

$$N_u < \bar{N}_u = \alpha \times \frac{Br \times f_{c28}}{0.9 \times 1.5} = 0.416 \times \left(\frac{0.65 \times 25}{0.9 \times 1.5} \right) = 5.007 \text{ MN} = 5007 \text{ KN}$$

So

$$N_u = 1419.2854 \text{ KN} < \bar{N}_u = 5007 \text{ KN} \dots\dots\dots \text{CV}$$

Vertical reinforcement combination 0,8G±E

Determination of stresses :

$$\sigma_1 = \frac{N}{A} + \frac{M}{I} Y$$

$$\sigma_1 = \frac{921.589 \times 10^{-3}}{0.75} + \frac{2377.7462 \times 10^{-3}}{1.5625} \times 2.5 = 5.03 \text{ MPa} > 0$$

$$\sigma_2 = \frac{N}{A} - \frac{M}{I} Y$$

$$\sigma_2 = \frac{921.589 \times 10^{-3}}{0.75} - \frac{2377.7462 \times 10^{-3}}{1.5625} \times 2.5 = -2.57 \text{ MPa} < 0$$

($\sigma_1 > 0$, $\sigma_2 < 0$), so the section is partially compressed

Length of the compressed zone

$$L_c = L \times \frac{|\sigma_2|}{|\sigma_1 + \sigma_2|}$$

$$L_c = 5 \times \frac{2.57}{5.03 + 2.57} = 1.69$$

$$L_c = 1.69 \text{ m}$$

Length of the tense zone

$$L_T = L - L_c$$

$$L_T = 5 - 1.69 = 3.31 \text{ m}$$

Width of vertical strip d

$$d \leq \min \left\{ \frac{h_e}{2}; \frac{2}{3} L_T \right\} = \min \left\{ \frac{3.06}{2}; \frac{2}{3} \times 3.31 \right\} = \min \{1.53; 2.20\}$$

$$d = 1.53 \text{ m}$$

Calculation of σ'_2

$$\sigma'_2 = \text{tng}(\alpha) \times (L_T - d)$$

With:

$$\text{tng } \alpha = \frac{\sigma_2}{L_T} = \frac{2.57}{3.31} = 0.77$$

$$\sigma'_2 = 0.77 \times (3.31 - 1.53) = 1.3706 \text{ MPa}$$

$$I' = \frac{e \times d^3}{12} = \frac{0.15 \times 1.53^3}{12} = 0.047 \text{ m}^4$$

$$y' = \frac{d}{2} = \frac{1.53}{2} = 0.765 \text{ m}$$

$$A' = e \times d = 0.15 \times 1.53 = 0.2259 \text{ m}^2$$

So:

$$N' = \frac{A'}{2} \times (\sigma_2 + \sigma'_2) = \frac{0.2259}{2} \times (-2.57 + 1.3706) = -0.13 \text{ KN}$$

$$M' = \frac{I'}{2y'} (\sigma_2 + \sigma'_2) = \frac{0.047}{2 \times 0.765} \times (-2.57 + 1.3706) = -0.037 \text{ KN.m}$$

The eccentricity

$$e_0 = \frac{M'}{N'} = \frac{-0.037}{-0.13} = 0.28 \text{ m}$$

We take: $c = c' = 0.05 \text{ m}$

$$e_1 = \frac{d}{2} - e_0 - c' = \frac{1.53}{2} - 0.28 - 0.05 = 0.435 \text{ m}$$

$$e_2 = \frac{L}{2} + e_0 - c' = \frac{5}{2} + 0.28 - 0.05 = 2.73 \text{ m}$$

The reinforcement A_s :

Will be:

$$A_{s1} = \frac{N' \times e_2}{(e_1 + e_2)f_e} = \frac{0.13 \times 2.73}{(0.435 + 2.73) \times 400} = 2.8 \times 10^{-4} m^2 = 2.80 \text{ cm}^2$$

$$A_{s2} = \frac{N' \times e_1}{(e_1 + e_2)f_e} = \frac{0.13 \times 0.435}{(0.445 + 2.475) \times 400} = 4.46 \times 10^{-4} m^2 = 4.46 \text{ cm}^2$$

$$A_s = A_{s1} + A_{s2} = 2.8 \text{ cm}^2 + 4.46 \text{ cm}^2 = 7.26 \text{ cm}^2$$

For 1 ml :

$$A_s = \frac{7.26}{5} = 1.453 \text{ cm}^2/ml$$

For the stretched length RPA

$$A_{s \min} = 0,2\% \cdot e \cdot L_T = \frac{0,2}{100} \times 15 \times 331 = 9.93 \text{ cm}^2$$

Overall, in the wall section RPA :(art.7.7.4.3):

→ 0,15% section du voile

$$A_{s \min} = \frac{0,15}{100} \cdot e \cdot L = \frac{0,15}{100} \times 15 \times 500 = 11.25 \text{ cm}^2$$

For 1 ml

$$A_{s \min} = \frac{11.25}{5} = 2.25 \text{ cm}^2/ml$$

In the current zone : $A_{s \min} = 0,10\% \cdot S$ of wall

$$A_{s \min} = \frac{0,10}{100} \times 7500 = 7.5 \text{ cm}^2$$

$$\text{For 1 ml} = \frac{7.5}{5} = 1.5 \text{ cm}^2/ml$$

Reinforcement choice :

- In the current zone

$$A_s = \text{Max}\{A_s ; A_{s \min RPA}\}$$

$$A_s = \text{Max}\{1.453 \text{ cm}^2 ; 1.5 \text{ cm}^2\} \rightarrow A_s = 1.5 \text{ cm}^2/ml$$

We choose 4HA12 = 4.52 cm²

In this zone we take the spacing as follow

$$S_t \leq \min(1,5 \cdot e ; 30 \text{ cm})$$

$$S_t = \min(1,5 \times 15 ; 30 \text{ cm}) = \min(22.5 ; 30 \text{ cm}) = 22.5 \text{ cm}$$

We take: $S_t = 20 \text{ cm}$

- In the stretched zone or the end zone

$$A_s = \text{Max}\{A_s ; A_{s \min RPA}\} = \text{Max}\{1.453 \text{ cm}^2 ; 2.25 \text{ cm}^2\} = 2.25 \text{ cm}^2/ml$$

$$A_s = 2.25 \text{ cm}^2/ml$$

We take 4HA12 = 4.52 cm²**Spacing :**

$$S_t \leq \frac{S_t}{2} = \frac{20}{2} = 10 \text{ cm} \rightarrow S_t = 10 \text{ cm}$$

End area length :

$$\frac{L}{10} = \frac{500}{10} = 50 \text{ cm}$$

Horizontal reinforcement :

The reinforcement will be done for a strip of 1m.

The shear stress in concrete is limited as follows:

$$\tau_u \leq \bar{\tau}_u$$

$$\bar{\tau}_u = 0.2 \times f_{c28} = 5 \text{ MPa}$$

$$\tau_u = \frac{1.4 \times T_{max}}{e \times L}$$

$$\tau_u = \frac{380.325 \times 10^{-3}}{0.15 \times 5} = 0.71 \text{ MPa} \leq \bar{\tau}_u \dots\dots\dots \text{CV}$$

Calculation of transversal reinforcement : CBA93 (art.5.1.2.3)

$$\frac{A_t}{e \times S_t} \geq \frac{\gamma \times (\tau - 0.3 f_{t28} \times K)}{0.9 \times f_e}$$

$$K = 0$$

Spacing :

$$S_t \leq \min(15e, 30\text{cm})$$

$$S_t \leq \min(225 \text{ cm}, 30\text{cm}) = 30 \text{ cm}$$

We take $S_t = 20 \text{ cm}$

$$A_t = \frac{e \times S_t \times \tau}{0.9 \times f_e} = \frac{15 \times 20 \times 0.71}{0.9 \times 400} = 0.6 \text{ cm}^2$$

Calculation of the horizontal reinforcement :

We do the calculation for a band of 1m:

According to RPA99/2003:

$$A_{s \text{ min}} = 0.10\% \times e \times L = 0.10\% \times 15 \times 500 = 7.5 \text{ cm}^2$$

$$\text{For 1ml } A_{s \text{ min}} = \frac{7.5}{5} = 1.5 \text{ cm}^2$$

$$A_s = \text{Max}\{A_t ; A_{\text{min}}\} = A_s = \text{Max}\{0.6 ; 1.5\} = 1.5 \text{ cm}^2$$

We take: :3HA14=4,62 cm²

The same approach is used for other walls.

VI.4.6 Shema of reinforcement :

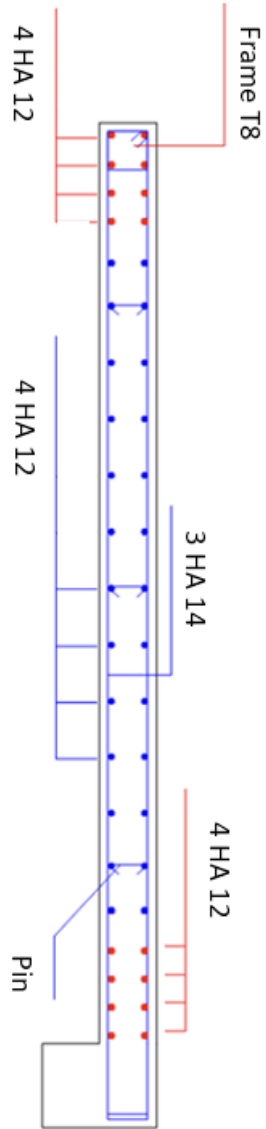

Figure IV.10 Reinforcement of the wall

Chapter

VII

Chapter VII

Calculation of the infrastructure:

VII.1 Introduction:

The foundation of a given structure is the element that acts as the interface between the structure and the ground, ensuring that the loads of the structure (self-weight, weather and service overloads) are well transferred and distributed to the ground. The type of foundation is determined by examining the soil to ensure the structure is strong. Depends on the bearing capacity of the soil: either the existing soil has sufficient properties to support the plant, or it has poorer properties and needs to be reinforced or other solutions considered.

VII.2 Foundation choice:

In the case of foundations, we distinguish:

- Superficial foundations (Strip foundation, long strip foundation, rafts).
- Deep foundation (Pier, piled).
- Surface foundations or rafts (Flat slab raft, finned rafts...).

The choice of the type of the foundation depends on several parameters that are:

- The type of the structure.
- The characteristics of the soil.
- The economic aspect.
- The realization method.

With admissible stress of: 2.2 bar it is necessary to project a priori, superficial foundations of type:

- Isolated footing.
- Strip (continuous) footing under walls.

According to RPA99/2003 (Article 10.2), the choice of footing is made according to the following conditions:

- $\frac{\Sigma \text{footing}}{S_{\text{building}}} < 50 \% \Rightarrow$ Isolated footing.
- $\frac{\Sigma \text{footing}}{S_{\text{building}}} < 50 \% \Rightarrow$ Strip footing.

VII.3 Study of isolated footing:

Determination of footing dimensions:

$$e_0 = \frac{M_{ser}}{N_{ser}} \times \frac{N_{ser}}{A^2} \leq \sigma_{adm}$$

“No Lift” Stability Condition:

$$e_0 \leq \frac{A}{6}$$

$$e = \frac{M}{N} \leq \frac{B}{4}$$

Stiffness condition: (art 15.II.2 BAEL91/99; P227)

$$d \geq \max\left(\frac{A-\alpha}{4}; \frac{B-b}{4}\right)$$

$$h = d + 5 \text{ cm}$$

Punching condition:

$$c \geq 1.44 \sqrt{\frac{N}{\sigma_{bc}}}$$

Reinforcement:(BAEL91/99 art 15.VII; P250 /251)

$$\sigma_1 = \frac{N_u}{A.B} \left(1 + \frac{6e_0}{B}\right)$$

$$\sigma_2 = \frac{N_u}{A.B} \left(1 - \frac{6e_0}{B}\right)$$

$$\sigma_{moy} = \frac{\sigma_1 + 3\sigma_2}{4}$$

$$N_{Total} = N_{ser} + P_{footing}$$

$$A_x = \frac{N_{total} \times (A - \alpha)}{8 \times h \times \sigma_s}$$

$$A_y = \frac{N_{total} \times (B - b)}{8 \times h \times \sigma_s}$$

Calculation of the free height:

$$h' = 6\phi + 6 \text{ cm}$$

VII.3.1 Calculation example:

The footing is pre-sized at ULS and reinforced at SLS.

Either a footing insulated under the most solicited column.

For the square footing given $a=b$ so $S=A^2$

For the rectangular footing on $A/B = a/b$ therefore where $A = \frac{a}{b} \times B$

ULS:

$$N_u = 1503.325 \text{ KN}$$

$$M_u = 0.5933 \text{ KN.m}$$

SLS:

$$N_s = 1102.86 \text{ KN}$$

$$M_s = 0.428 \text{ KN.m}$$

Determination of footing dimensions:

Consider a rectangular footing $A \times B$ located under a square column:

$$\frac{A}{B} = \frac{a}{b} \rightarrow \frac{A}{B} = 1 \rightarrow A = B$$

$$e_0 = \frac{M_{ser}}{N_{ser}} = \frac{0.428}{1102.86} = 0.0004$$

$$\frac{N_{ser}}{A^2} \leq \sigma_{adm}$$

$$A^2 \geq \frac{N_{ser}}{\sigma_{adm}} \rightarrow A \geq \sqrt{\frac{1102.86}{220}} \rightarrow A \geq 2.238 \text{ We take } A = B = 2.3 \text{ m}$$

“No Lift” Stability Condition:

$$e_0 \leq \frac{2.3}{6} \Rightarrow 0.0004 < 0.38 \dots\dots CV$$

Stiffness condition: (art 15.II.2 BAEL91/99; P227)

To satisfy the condition of the stiffness of the footing, the height of the footing must be:

$$d \geq \max \left(\frac{A-\alpha}{4}; \frac{B-b}{4} \right)$$

$$d \geq \max \left(\frac{2.3-0.40}{4}; \frac{2.3-0.40}{4} \right)$$

$$d \geq \max (0.475; 0.475) \rightarrow d = 50 \text{ cm}$$

$$h = d + 5 \text{ cm} = 50 + 5 = 55 \text{ cm}$$

Reinforcement: (BAEL91/99 art 15.VII; P250 /251)

$$\sigma_1 = \frac{N_u}{A.B} \left(1 + \frac{6e_0}{B} \right) = 208.69 \text{ KN/m}^2$$

$$\sigma_2 = \frac{N_u}{A.B} \left(1 - \frac{6e_0}{B} \right) = 208.26 \text{ KN/m}^2$$

$$\sigma_{moy} = \frac{\sigma_1 + 3\sigma_2}{4} = 208.37 \text{ KN/m}^2$$

$$\sigma_{moy} = 208.37 \text{ KN/m}^2 < \sigma_{adm} = 220 \text{ KN/m}^2$$

$$h_{moy} = \frac{h+e}{2}$$

$$\text{With: } e = \frac{h}{2} = 27.5 \text{ cm}$$

$$h_{moy} = 41.25 \text{ cm}$$

$$P_{footing} = 25 \times 2.3 \times 2.3 \times 0.41 = 54.22 \text{ KN}$$

$$N_{Total} = N_{ser} + P_{footing}$$

$$N_{Total} = 1157.08 \text{ KN}$$

$$A_x = A_y = \frac{N_{total} \times (A - \alpha)}{8 \times h \times \sigma_s} = \frac{1157.08 \times (2.3 - 0.40)}{8 \times 0.55 \times 2.2} = 22.71 \text{ cm}^2$$

$$\text{We take: } 15HA14 = 23.08 \text{ cm}^2$$

Calculation of the free height:

$$h' = 6\phi + 6 \text{ cm} = 14.4 \text{ cm} \Rightarrow h' = 15 \text{ cm}$$

Calculation of the reinforcement spacing:

$$S_t \leq \min (20\text{cm}; 15\phi) = \min (20\text{cm}; 21\text{cm})$$

So, $S_t = 20 \text{ cm}$

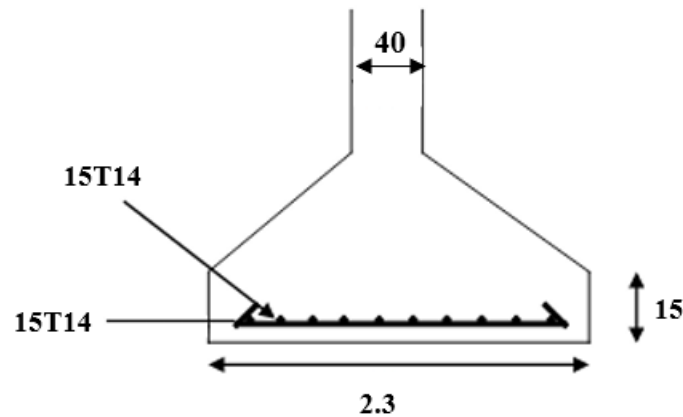

Figure VII.1 Reinforcement of isolated footing

VII.4 Study of Strip footing under walls:

When the columns and possibly the walls in a given direction, are close to each other, a continuous footing is made under this line of columns and walls.

The footing, which can be more or less rigid, is often associated with a central beam of rigidity (beam release), likely to distribute the point pressures introduced by the columns, and the linearly distributed pressures produced by the walls.

Transversely, the footing acts as a trapezoidal footing under column, for a width a one will have a reinforcement section calculated according to the method of the connecting rods if it is applicable.

Longitudinally the footing acts as a continuous inverted beam with the columns and walls as supports, hence the upper reinforcement to resume the positive moment in span, and the lower reinforcements to take the negative moments in support.

VII.4.1 Calculation example :**Dimensioning (SLS):**

- Length: $L = 3.35 \text{ m}$
- Width: $B = 1.5 \text{ m}$
- The height: h

The total height of the sole (h_t) is determined by the following equation:

$$h_t \geq \max \left(\frac{A-a}{4}; d' \right)$$

With: d' is the reinforcement coating $\rightarrow d' = 5 \text{ cm}$

$$h_t \geq \max \left(\frac{1.5-0.40}{4}; 0.05 \right) \rightarrow h_t \geq 0.275$$

We take $h_t = 50$ cm

$$h_p = \frac{h}{3} = \frac{50}{3} = 16.66 \text{ cm}$$

We take $h_p = 20$ cm

Reinforcement (ULS):

At the third condition the maximum values between the stresses of the wall and the stresses in the column was taken as normal stress and moment in relation to the longitudinal axis of the footing.

These same efforts will be used for the calculation of the reinforcement transversal.

$$N_u = 1571.01 \text{ KN}$$

$$M_u = 15.05 \text{ KN.m}$$

○ Main reinforcement:

$$A_s = \frac{N_u(B-b)}{8.d.\sigma_s} = \frac{1571.01 \times (1.5-0.40)}{8 \times 0.40 \times 348 \times 10^3} = 15.15 \text{ cm}^2$$

We take: **8HA16 = 16.08 cm²**

Calculation of the reinforcement spacing:

$$S_t = 100 \times \frac{1HA16}{16.08} = 12.5 \text{ cm} \Rightarrow S_t = 15 \text{ cm}$$

○ Distribution reinforcement:

$$A_r = A_s \times \frac{B}{4} = 16.08 \times \frac{1.5}{4} = 6.03 \text{ cm}^2$$

We take: **6HA12 = 6.78 cm²**

Reinforcement spacing:

$$S_t \leq \min (20\text{cm}; 15\phi) = \min (20\text{cm}; 18\text{cm})$$

So, $S_t = 15$ cm

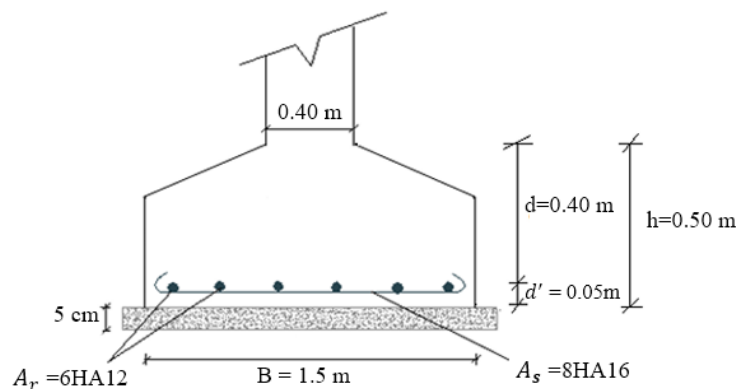

Figure VII.2 Reinforcement of Strip footing

VII.5 Study of the Sill:

A sill is a structural element having the shape of a horizontal rectangular bi-directional reinforced concrete beam with the role of support of significant loads and transfer them to the supports, cross-connection between the columns at the level of the foundations.

VII.5.1 Dimensions of the Sill:(RPA99V2003 art 10-1-1)

The minimum cross-section dimensions of the sills are:

$(25 \times 30) \text{ cm}^2 \rightarrow$ category sites S2, S3.

$(30 \times 30) \text{ cm}^2 \rightarrow$ category sites S4.

In our case we have closed site S2, so we take the section: $(25 \times 30) \text{ cm}^2$

VII.5.2 Reinforcement of the Sill:

- Longitudinal reinforcement:

$$A = 0.6 \% \times b \times h$$

$$A = 0.6 \% \times 30 \times 25 = 4.5 \text{ cm}^2$$

$$\text{We take: } 6\text{HA}12 = 6.78 \text{ cm}^2$$

- Transversal reinforcement:

$$\text{We take: } 2\text{HA}8 = 8 \text{ cm}^2$$

The spacing is like this:

$$S_t \leq \min (20\text{cm}; 15\phi) = \min (20; 15 \times 1.2)$$

$$S_t \leq \min (20\text{cm}; 18 \text{ cm})$$

$$\text{So, } S_t = 15 \text{ cm}$$

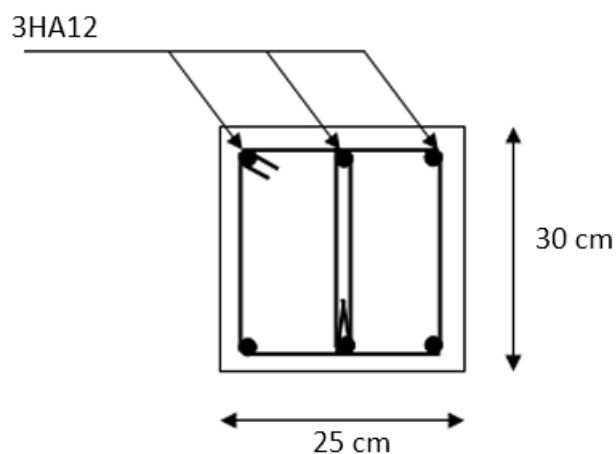
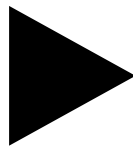

Figure VII.3 Reinforcement of sill



GENERAL CONCLUSION

The end of study project is an opportunity for the us to apply the knowledge acquired during our studies, and gain a comprehensive view of the engineer's responsibilities in construction, also allowed us to acquire knowledge on the methods of calculation and structural studies; the application of regulations such as : RPA99V2003 and CBA93 and BAEL91, the practice of software As : ETABS22 and AutoCAD, MATLAB...

On the other hand, through this work we were able to learn a lot of important information about calculation methods and knowing the regulatory standards texts, the testing of reinforced concrete structures.

This study allowed us to make some conclusions, the most important ones are:

- Exact consideration of the loads and overloads acting on the building for the proper conduct of the study.
- Proper sizing of the secondary elements ensures stability and good performance, preventing the occurrence of parasitic modes during an earthquake
- The good distribution of the rigidity in plan and in elevation by the installation of the walls which represent a keystone of the earthquake resistance.

Finally, the work we have presented allowed us to give a review of the knowledge we gained during our studies. This is not an end in itself, but a concrete step towards accumulation, experiments, gain knowledge and develop the creative thinking of the engineer.

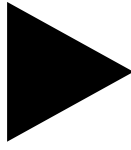

Keywords:

- Building: بناية
- Bending: الإنحناء
- Beam: رافدة
- Concrete: خرسانة
- Column: عمود
- Earthquake: الزلازل
- Ground floor : الطابق الأرضي
- Height : الإرتفاع
- Hollow block: أرضية مجوفة
- Infrastructure: البنية التحتية
- Isolated footing: أساس منعزل
- Length: الطول
- Loads : حمولات
- Parapet: جدار الحاجز
- Reinforcement: تسليح
- Reinforced concrete: خرسانة مسلحة
- Story : طابق
- Strength : القوة
- Steel : الحديد
- Strip footing: أساس مستمر
- Slab: أرضية
- Thickness: السمك
- The response spectrum : طيف الإستجابة
- Walls: جدران
- Width : العرض



BIBLIOGRAPHY:

Rules and References:

- 1- Centre for Applied Research in Seismic Engineering. Algeria. Regulator Technical Document DTR BC 2-48 “RPA version 2003”.
- 2- Centre for Applied Research in Seismic Engineering. Algeria. Design and calculation rule CBA93 reinforced concrete structures. CGS edition,1993.
- 3- Centre for Applied Research in Seismic Engineering. Algeria. REGULATORY TECHNICAL DOCUMENT DTR B.C. 2.2 PERMANENT AND OPERATING LOADS.
- 4- Jean-Pierre Mougain : Reinforced concrete BAEL91, Paris.
- 5- Reinforced concrete course.
- 6- Cours Génie parasismique (Master2), Pr. BOUERED.H
- 7- Master Thesis.

Programs used in the making:

- 1- ETABS 2022.
- 2- MATLAB 2020.
- 3- Geogebra.
- 4- Microsoft Word 2019.
- 5- Excel.
- 6- Application of repose spectrum (BOUZERD HAMOUDI).
- 7- AUTOCAD 2016.



ANNEXE:**Reinforcement section****N on cm^2 \emptyset on mm**

N \emptyset	5	6	8	10	12	14	16	20	25	32	40
1	0.20	0.28	0.50	0.79	1.13	1.54	2.01	3.14	4.91	8.04	12.57
2	0.39	0.57	1.01	1.57	2.26	3.08	4.02	6.28	9.82	16.08	25.13
3	0.59	0.85	1.51	2.36	3.39	4.62	6.03	9.42	14.73	24.13	37.70
4	0.79	1.13	2.01	3.14	4.52	6.16	8.04	12.57	19.64	32.17	50.27
5	0.98	1.41	2.51	3.93	5.65	7.70	10.05	15.71	24.54	40.21	62.83
6	1.18	1.70	3.02	4.71	6.79	9.24	12.06	18.85	29.45	48.25	75.40
7	1.37	1.98	3.52	5.50	7.92	10.78	14.07	21.99	34.36	56.30	87.96
8	1.57	2.26	4.02	6.28	9.05	12.31	16.08	25.13	39.27	64.34	100.53
9	1.77	2.54	4.52	7.07	10.18	13.85	18.10	28.27	44.18	72.38	113.10
10	1.96	2.83	5.03	7.85	11.31	15.39	20.11	31.42	49.04	80.42	125.66
11	2.16	3.11	5.53	8.64	12.44	16.93	22.12	34.56	54.00	88.47	138.23
12	2.36	3.39	6.03	9.42	13.57	18.47	24.13	37.70	58.91	96.51	150.80
13	2.55	3.68	6.53	10.21	14.70	20.01	26.14	40.84	63.81	104.55	163.36
14	2.75	3.96	7.04	11.00	15.83	21.55	28.15	43.98	68.72	112.59	175.93
15	2.95	4.24	7.54	11.78	16.96	23.09	30.16	47.12	73.63	120.64	188.50
16	3.14	4.52	8.04	12.57	18.10	24.63	32.17	50.27	78.54	128.68	201.06
17	3.34	4.81	8.55	13.35	19.23	26.17	34.18	53.41	83.45	136.72	213.63
18	3.53	5.09	9.05	14.14	20.36	27.71	36.19	56.55	88.36	144.76	226.20
19	3.73	5.37	9.55	14.92	21.49	29.25	38.20	59.69	93.27	152.81	238.76
20	3.93	5.65	10.05	15.71	22.62	30.79	40.21	62.83	98.17	160.85	251.33

Flow chart 1: Simple traction

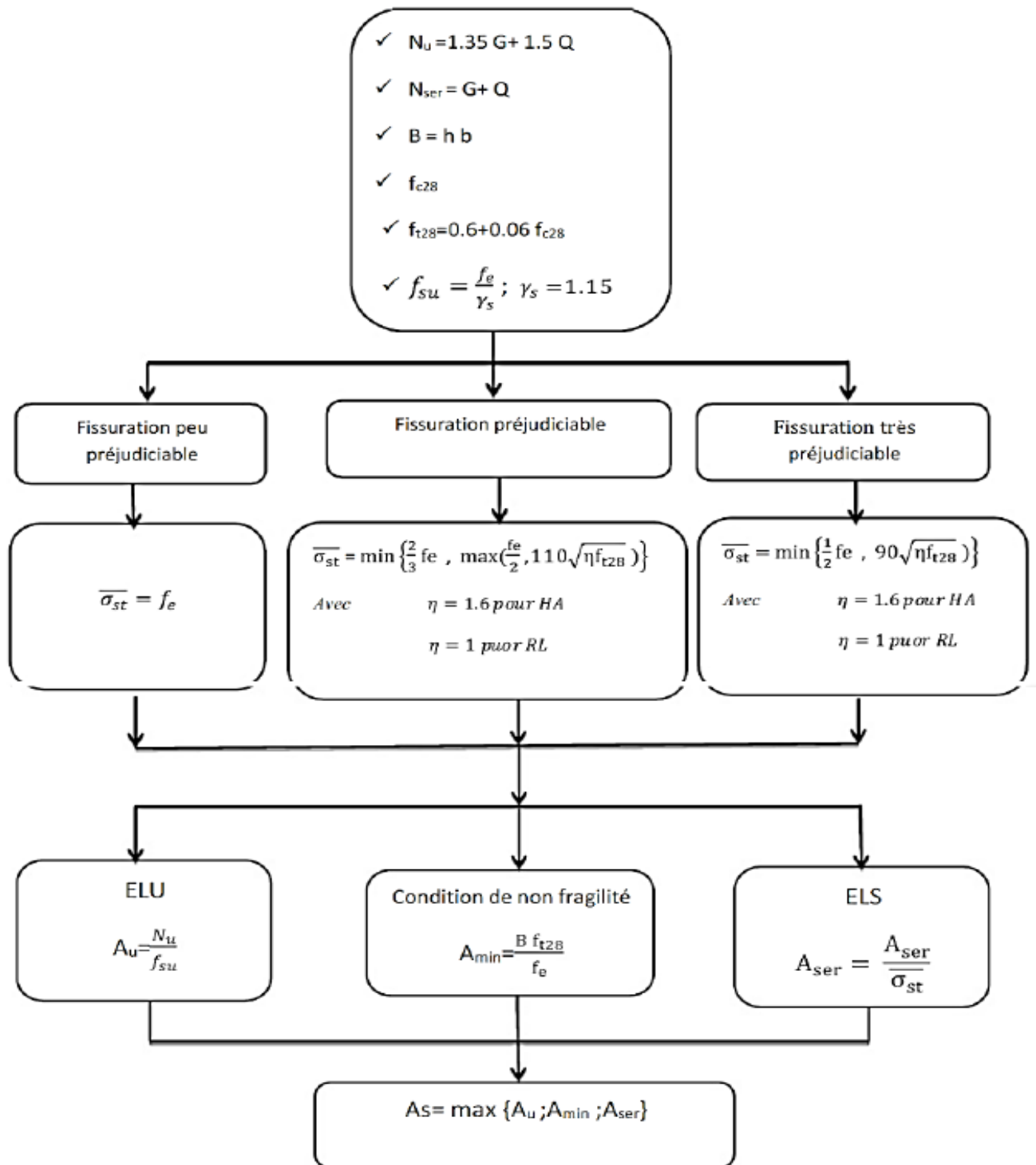

Flow chart 2: Simple bending of a rectangular section at the ULS

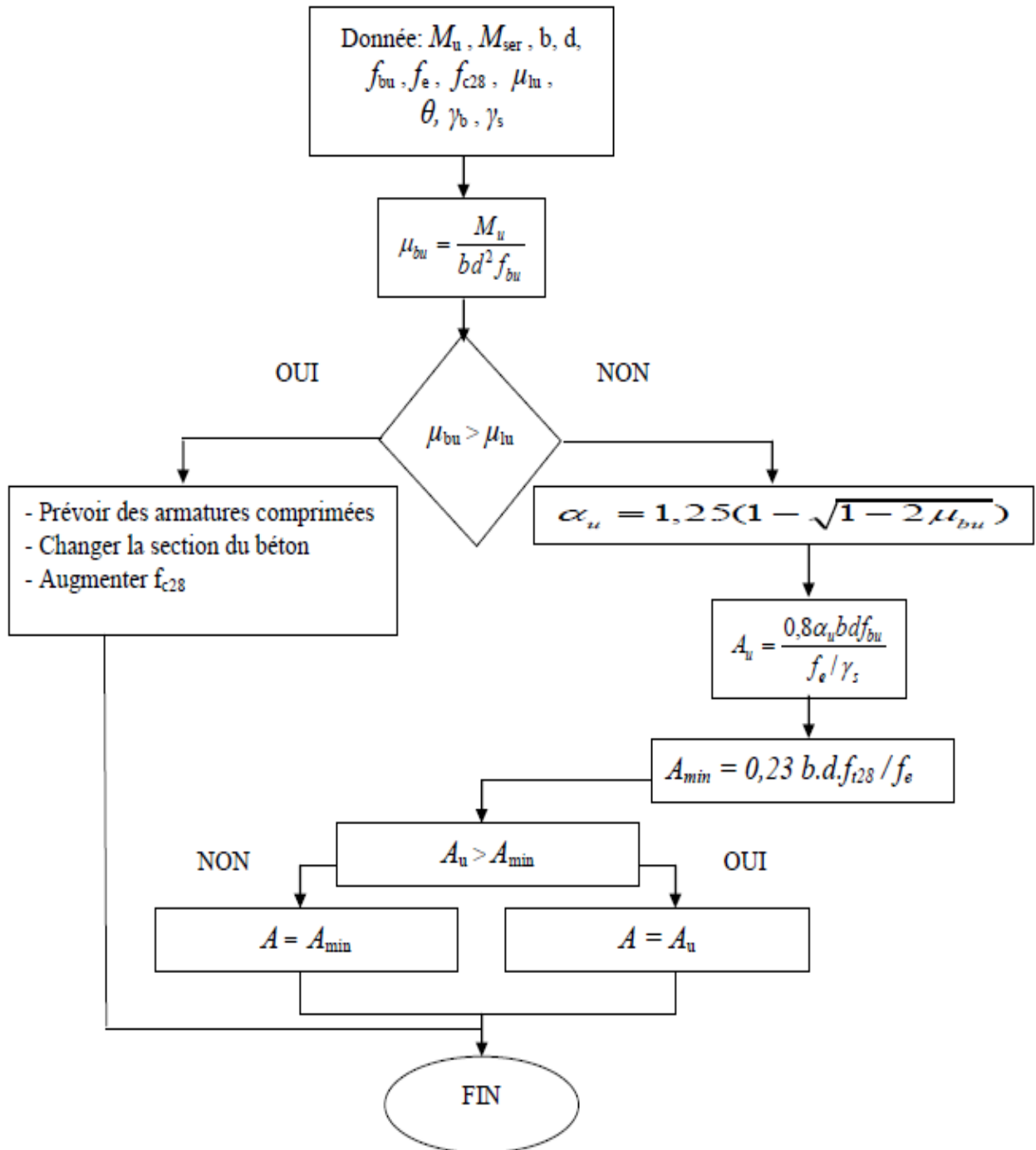

Flow chart 3: Calculating a rectangular section at the ULS in compound flexion:

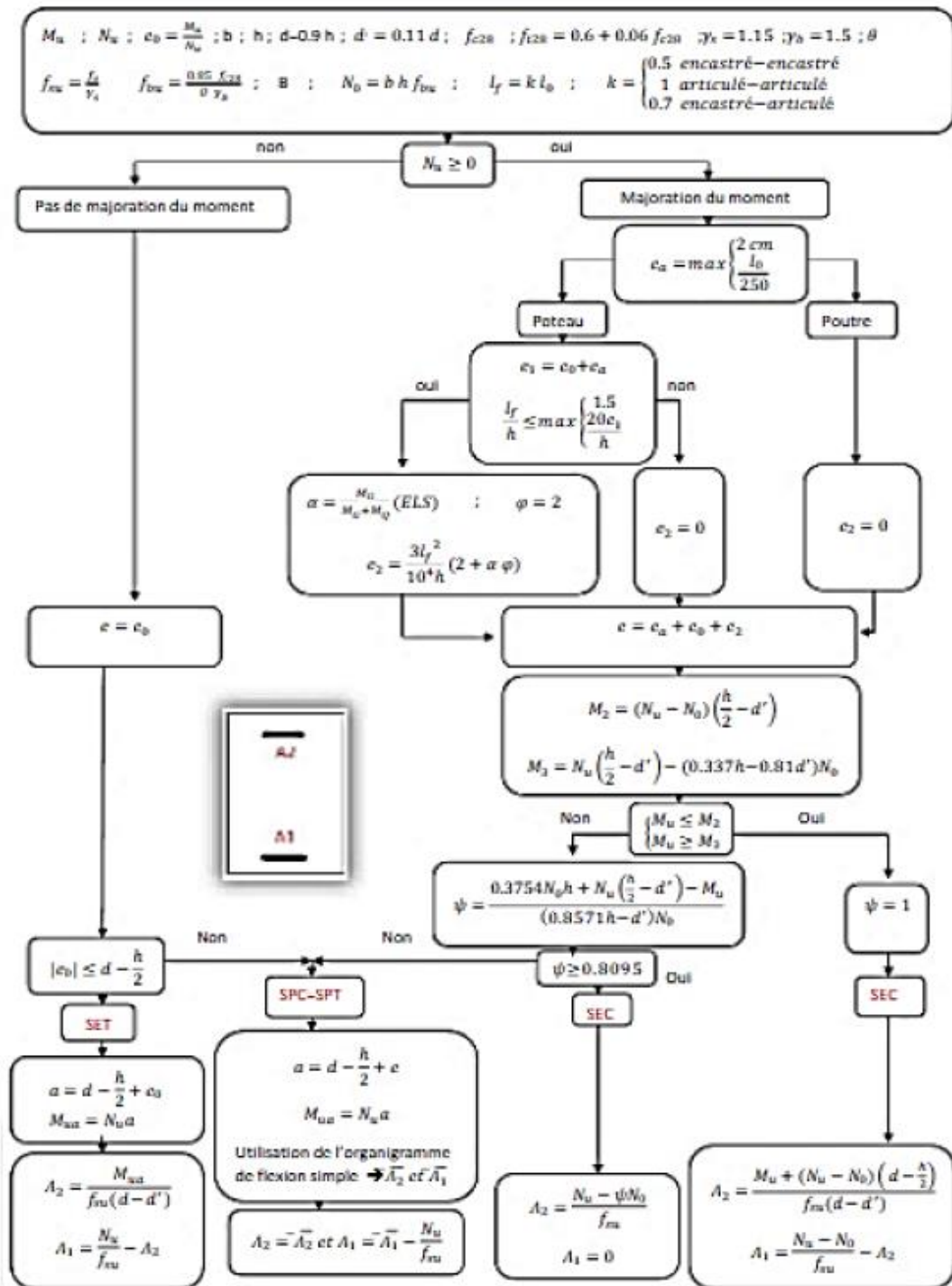

Flow chart 4: Calculating a rectangular section to the SLS in simple flexion:

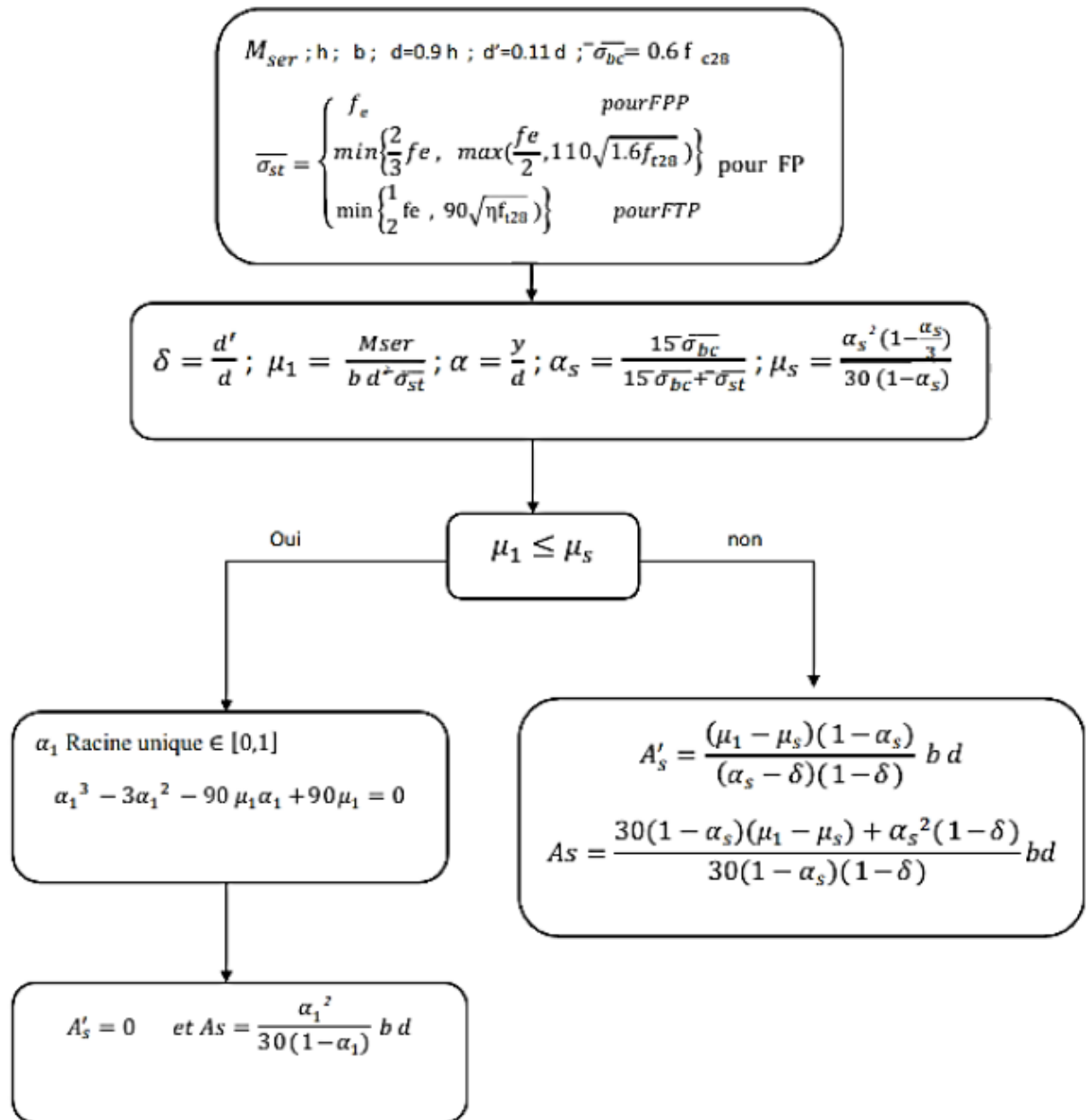

Flow chart 5: Checking the shear stress to the ULS:

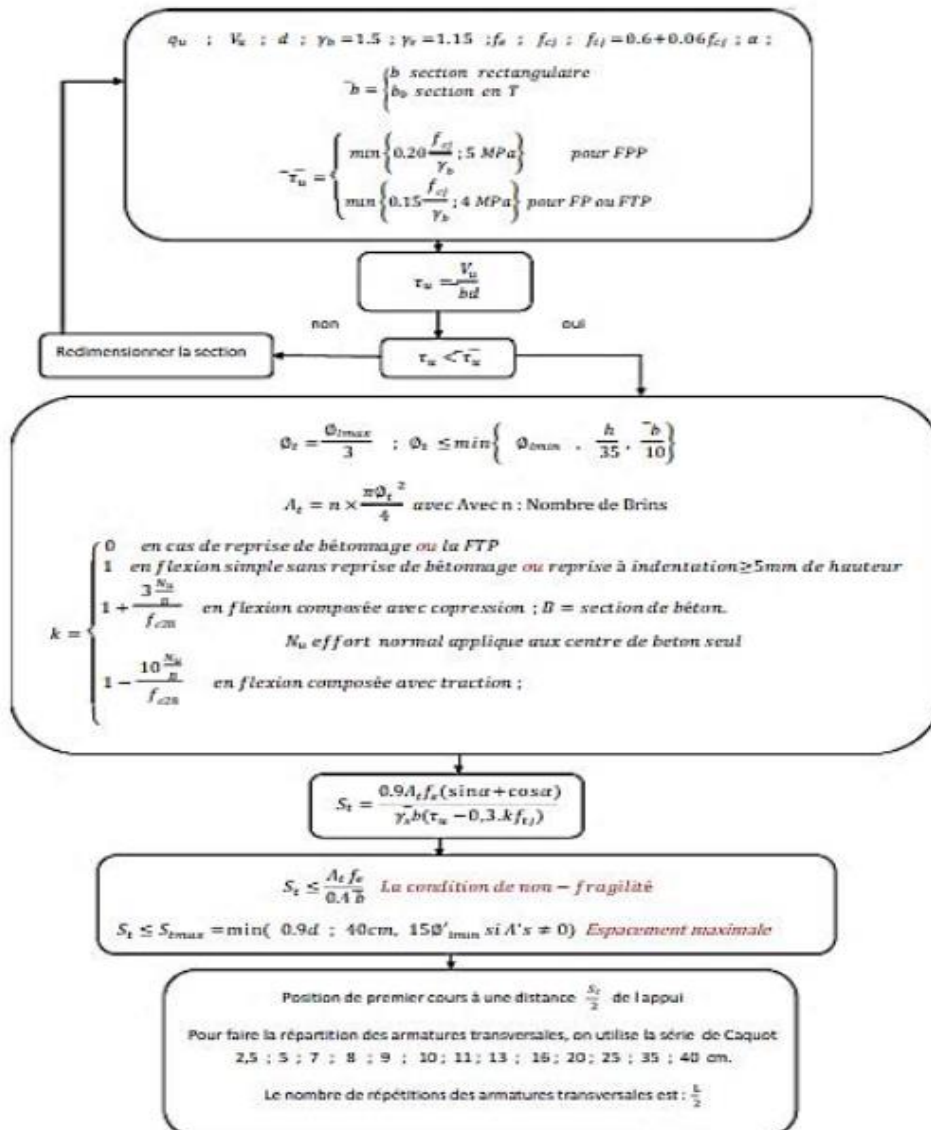

Flow chart 6: Check the constraint at ULS.

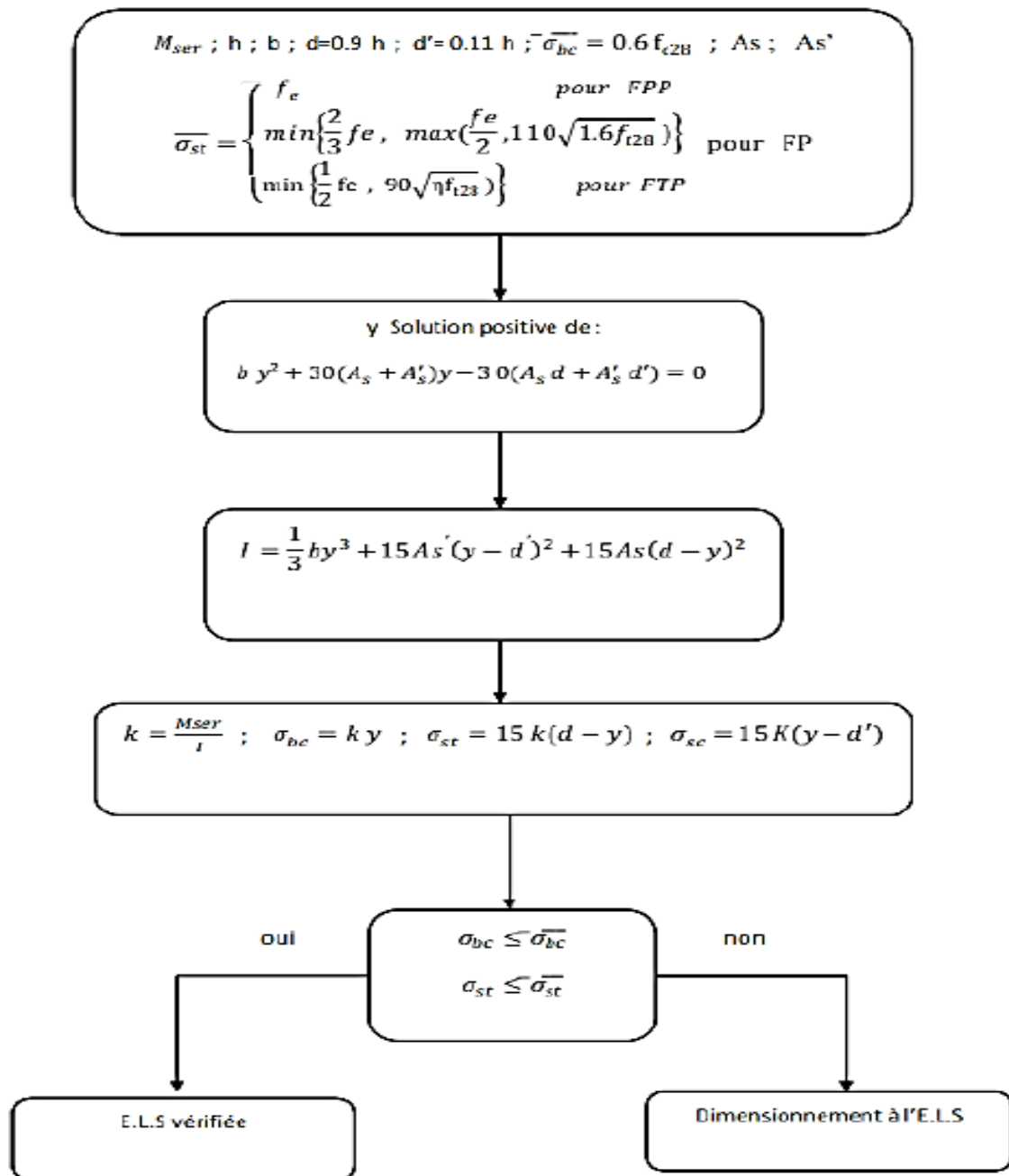

$\rho =$	$\nu = 0$		$\nu = 0,20$		$\rho =$	$\nu = 0$		$\nu = 0,20$	
	$\frac{l_x}{l_y}$	μ_x	μ_y	$\frac{l_x}{l_y}$		μ_x	μ_y	μ_x	μ_y
0,40	0,1094	0,250	0,1115	0,293	0,70	0,0683	0,436	0,0743	0,585
0,41	0,1078	0,250	0,1100	0,301	0,71	0,0670	0,450	0,0731	0,596
0,42	0,1062	0,250	0,1086	0,309	0,72	0,0658	0,464	0,0719	0,608
0,43	0,1047	0,250	0,1072	0,317	0,73	0,0646	0,479	0,0708	0,620
0,44	0,1032	0,250	0,1059	0,325	0,74	0,0634	0,494	0,0696	0,632
0,45	0,1017	0,250	0,1046	0,333	0,75	0,0622	0,509	0,0685	0,644
0,46	0,1002	0,250	0,1032	0,341	0,76	0,0610	0,525	0,0674	0,657
0,47	0,0988	0,250	0,1019	0,349	0,77	0,0598	0,542	0,0663	0,670
0,48	0,0974	0,250	0,1006	0,357	0,78	0,0587	0,559	0,0652	0,683
0,49	0,0960	0,250	0,0993	0,365	0,79	0,0576	0,577	0,0642	0,696
0,50	0,0946	0,250	0,0981	0,373	0,80	0,0565	0,595	0,0632	0,710
0,51	0,0932	0,250	0,0969	0,382	0,81	0,0553	0,613	0,0621	0,723
0,52	0,0918	0,250	0,0957	0,391	0,82	0,0542	0,631	0,0610	0,737
0,53	0,0905	0,250	0,0945	0,400	0,83	0,0531	0,649	0,0600	0,750
0,54	0,0892	0,250	0,0933	0,410	0,84	0,0520	0,667	0,0589	0,764
0,55	0,0879	0,250	0,0921	0,420	0,85	0,0509	0,685	0,0579	0,778
0,56	0,0865	0,253	0,0909	0,431	0,86	0,0498	0,693	0,0569	0,791
0,57	0,0852	0,266	0,0897	0,442	0,87	0,0488	0,721	0,0559	0,804
0,58	0,0838	0,279	0,0885	0,453	0,88	0,0478	0,740	0,0549	0,818
0,59	0,0825	0,292	0,0873	0,465	0,89	0,0468	0,759	0,0539	0,832
0,60	0,0812	0,305	0,0861	0,476	0,90	0,0458	0,778	0,0529	0,846
0,61	0,0798	0,317	0,0849	0,487	0,91	0,0448	0,798	0,0519	0,861
0,62	0,0785	0,330	0,0837	0,497	0,92	0,0438	0,819	0,0510	0,875
0,63	0,0772	0,343	0,0825	0,508	0,93	0,0428	0,841	0,0500	0,891
0,64	0,0759	0,356	0,0813	0,519	0,94	0,0419	0,864	0,0491	0,906
0,65	0,0746	0,369	0,0801	0,530	0,95	0,0410	0,888	0,0483	0,923
0,66	0,0733	0,382	0,0789	0,541	0,96	0,0401	0,911	0,0475	0,939
0,67	0,0720	0,395	0,0777	0,552	0,97	0,0393	0,934	0,0467	0,954
0,68	0,0707	0,408	0,0766	0,563	0,98	0,0385	0,956	0,0459	0,970
0,69	0,0695	0,422	0,0754	0,574	0,99	0,0377	0,978	0,0451	0,985
					1,00	0,0368	1,000	0,0442	1,000

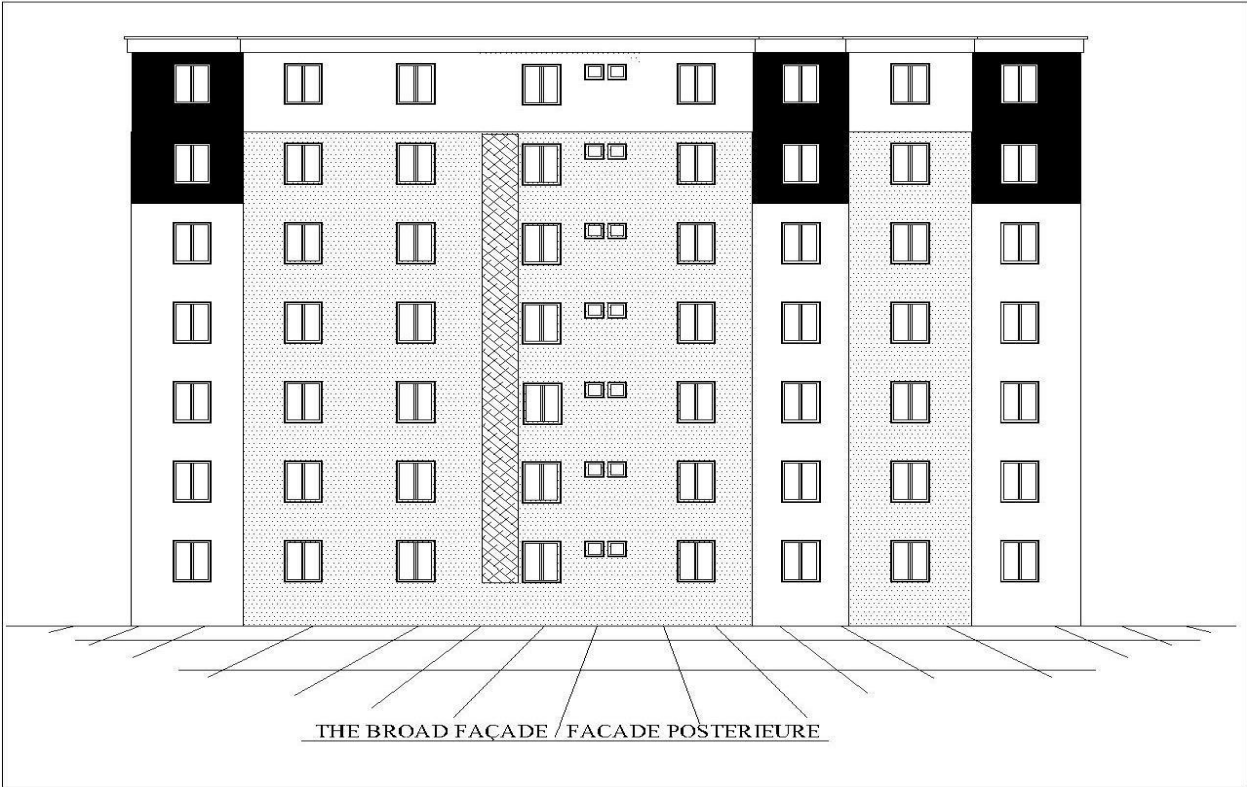
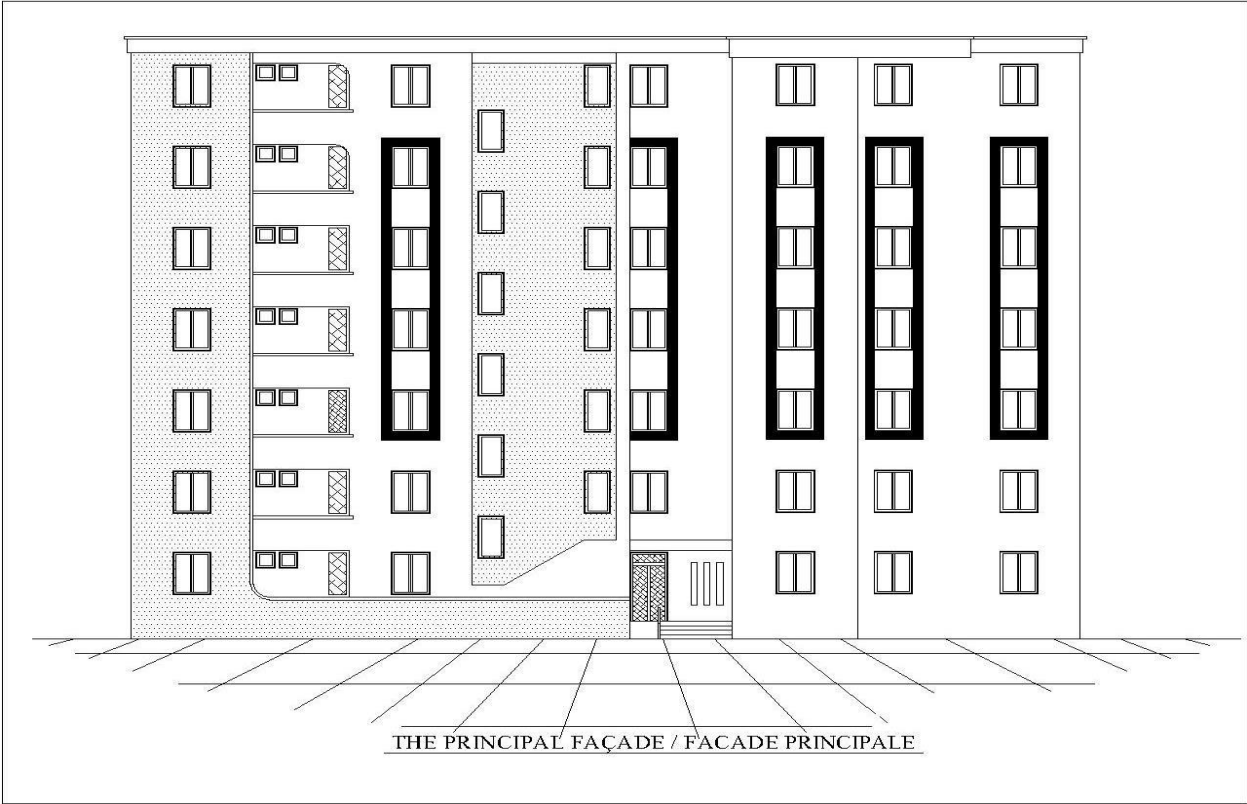

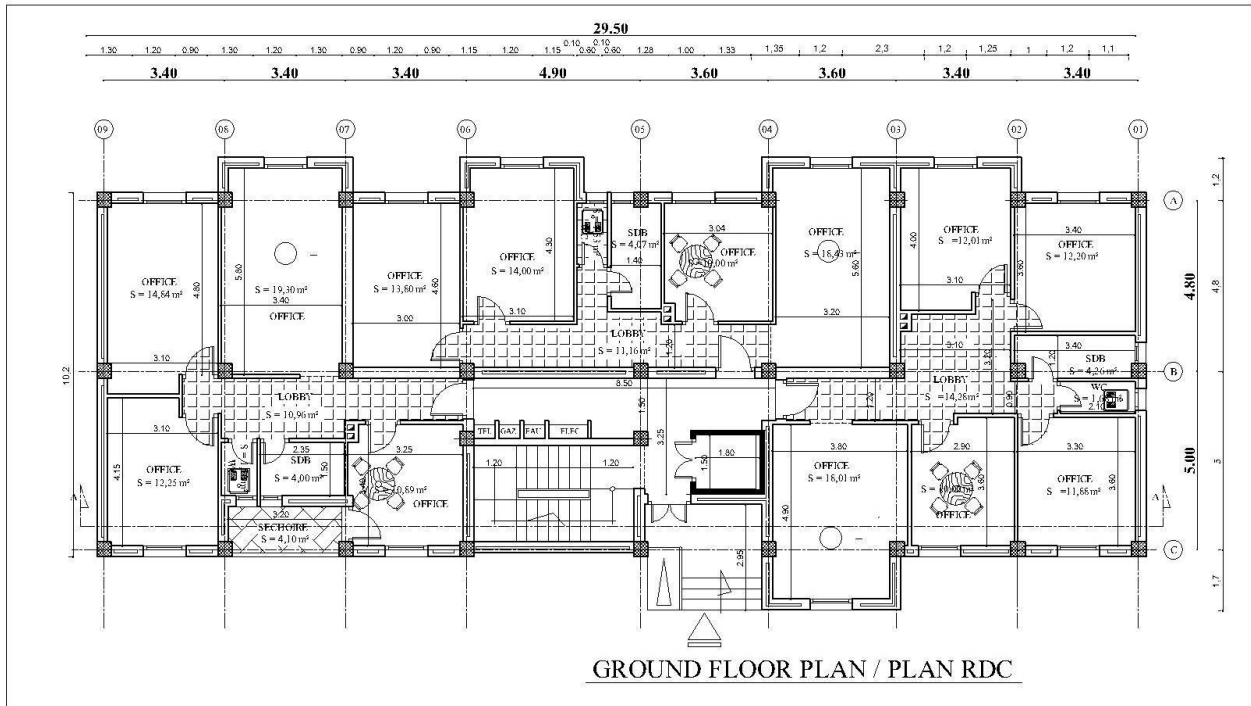
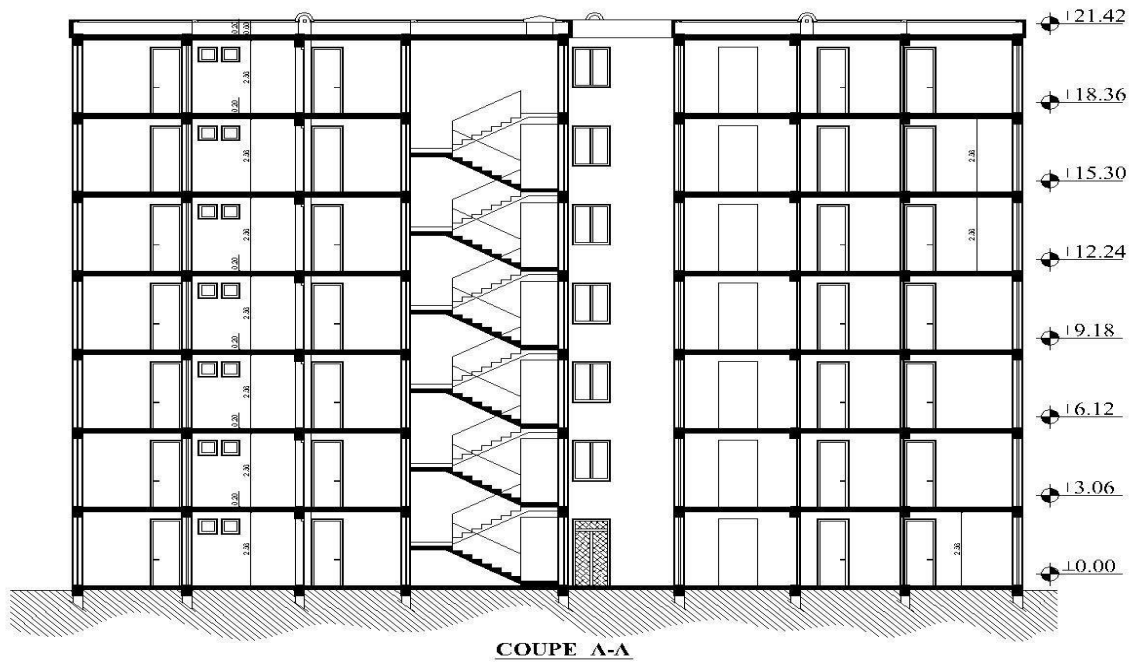

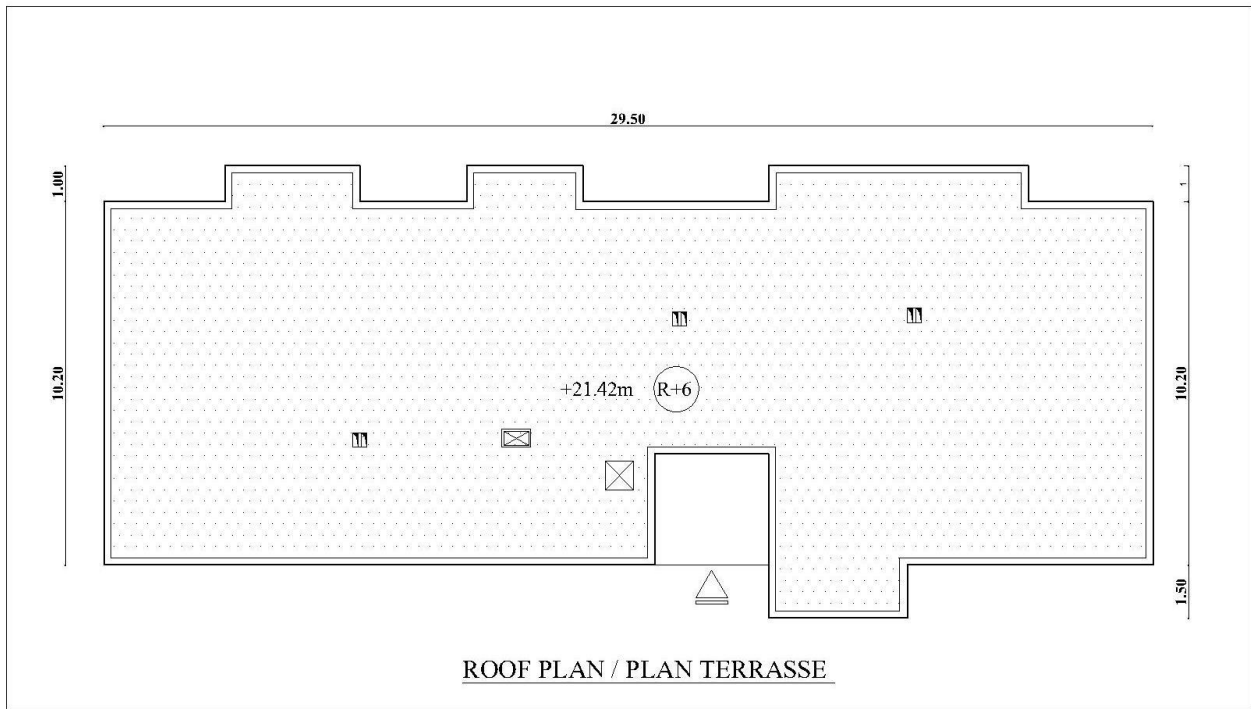
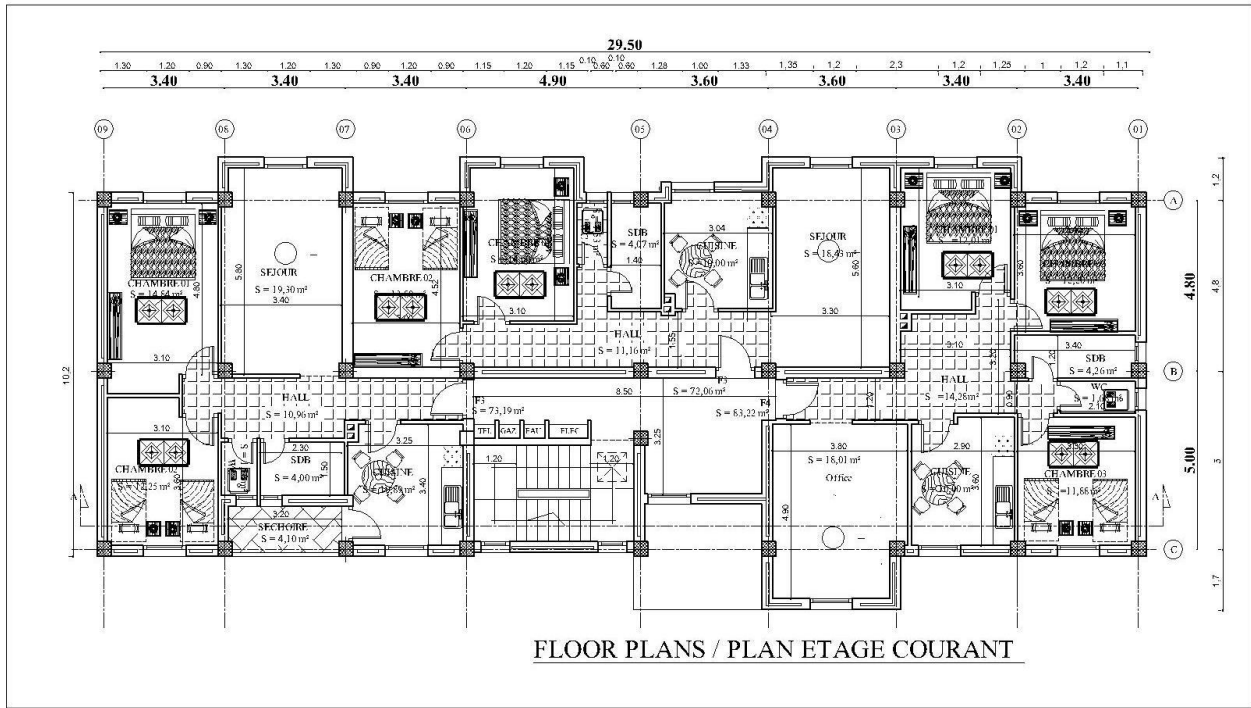

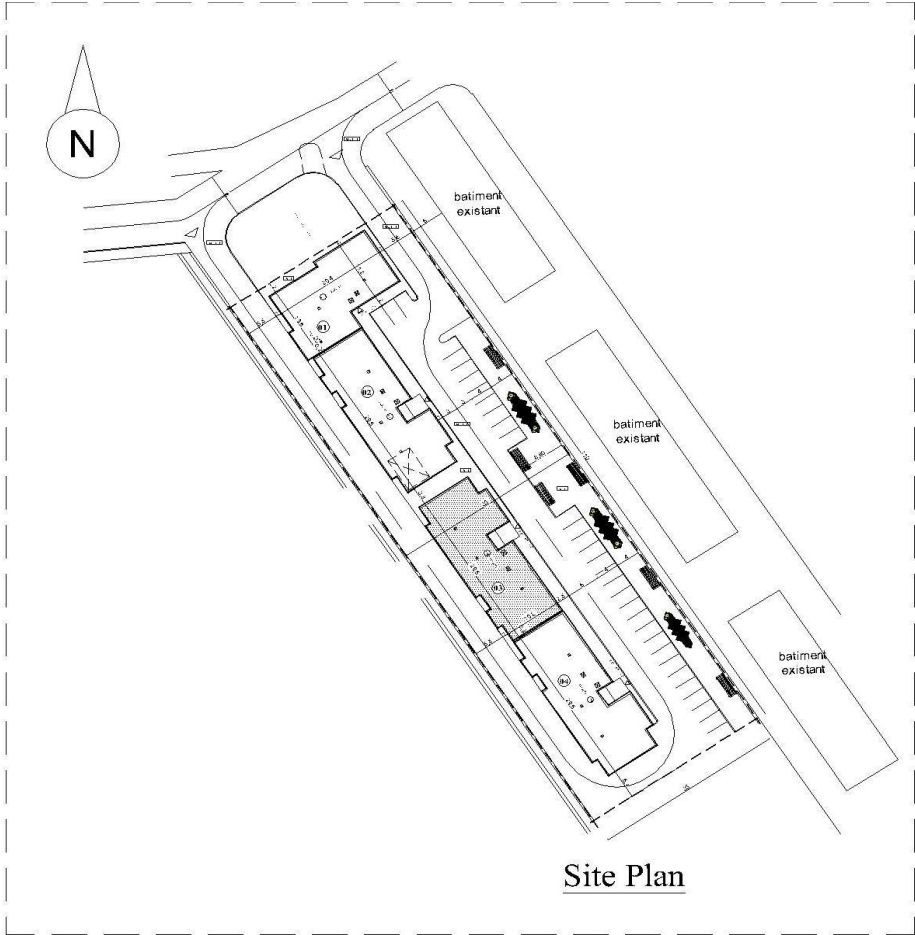

Site Plan

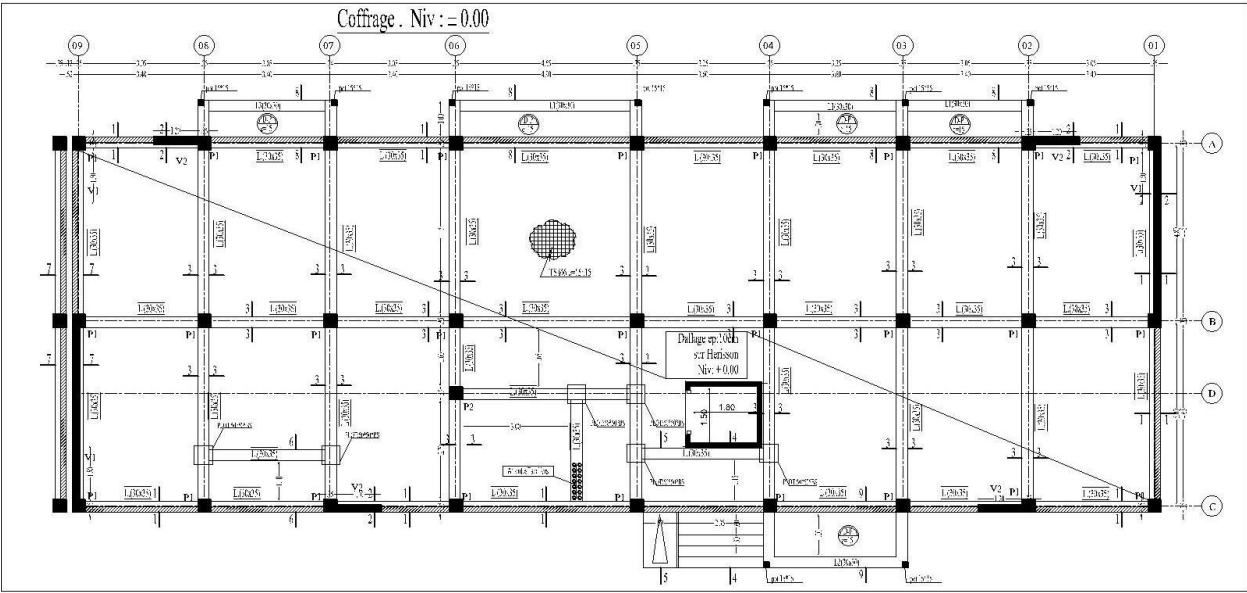

Coffrage . PLANCHER Niv +3.06,+6.12,-9.18,+12.24,+15.30-18.36+21.42

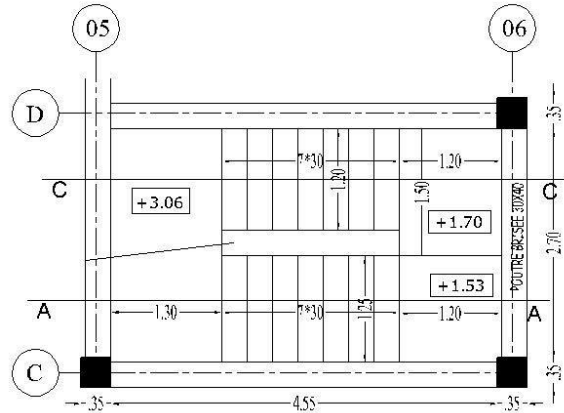
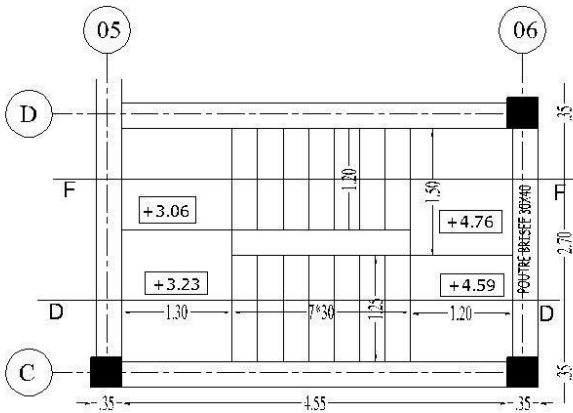
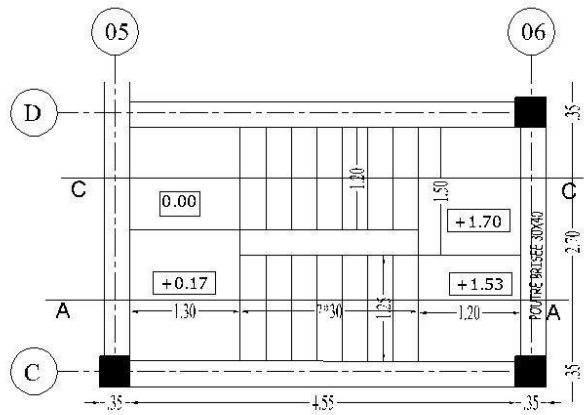
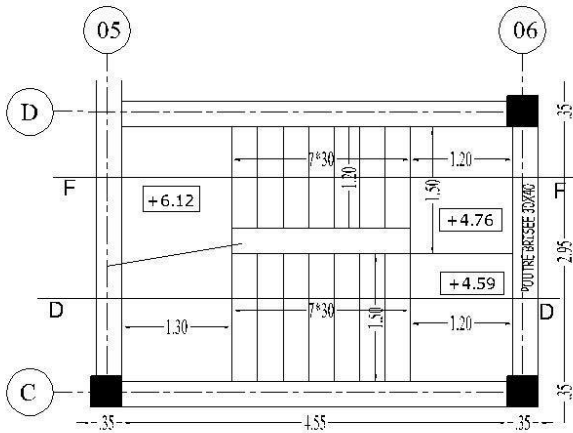
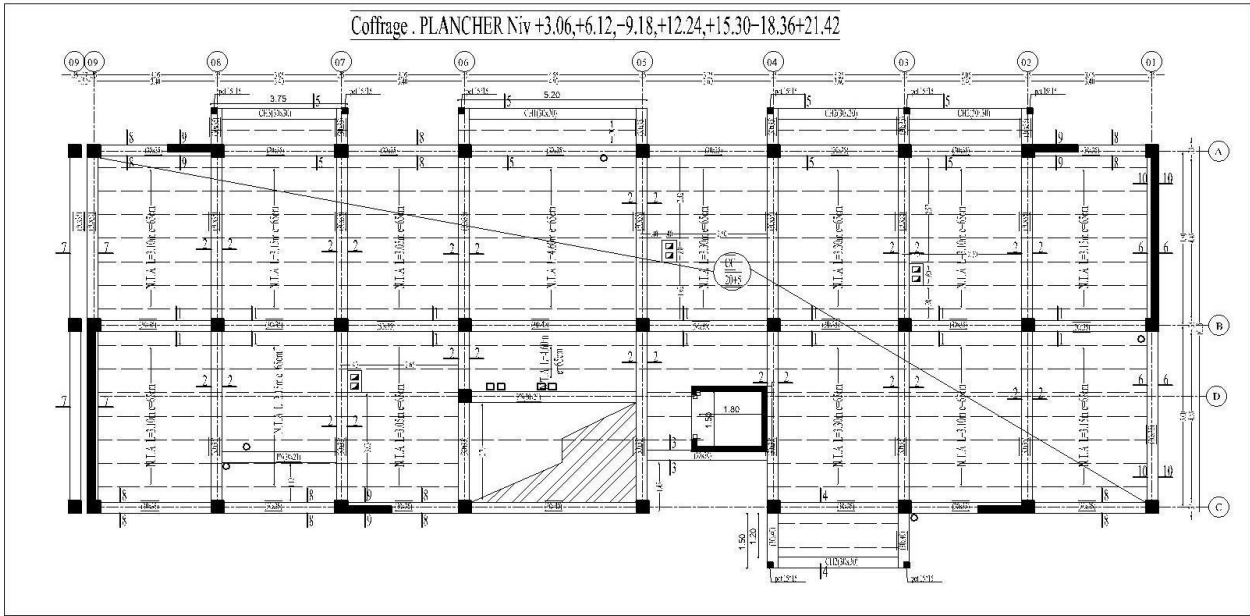

COUPE F-F

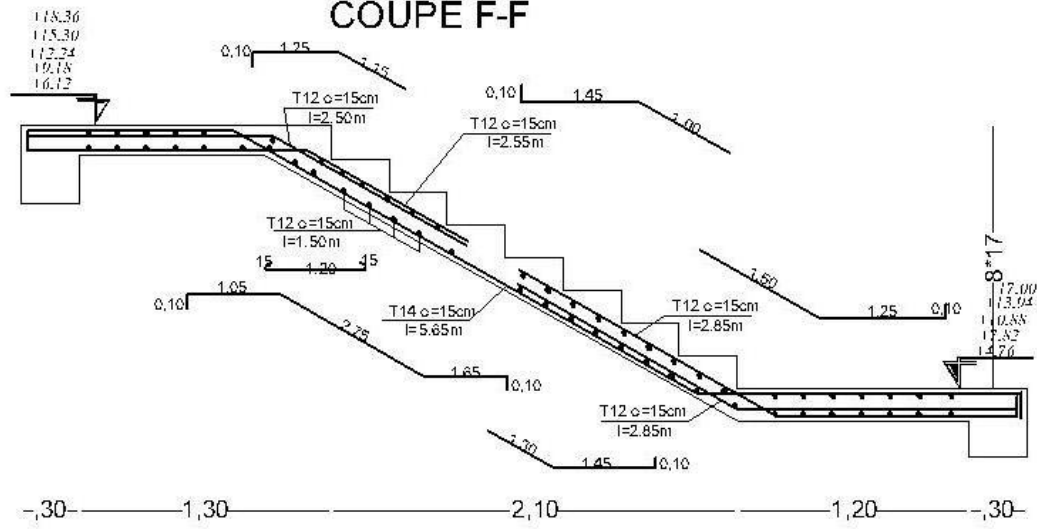

COUPE D-D

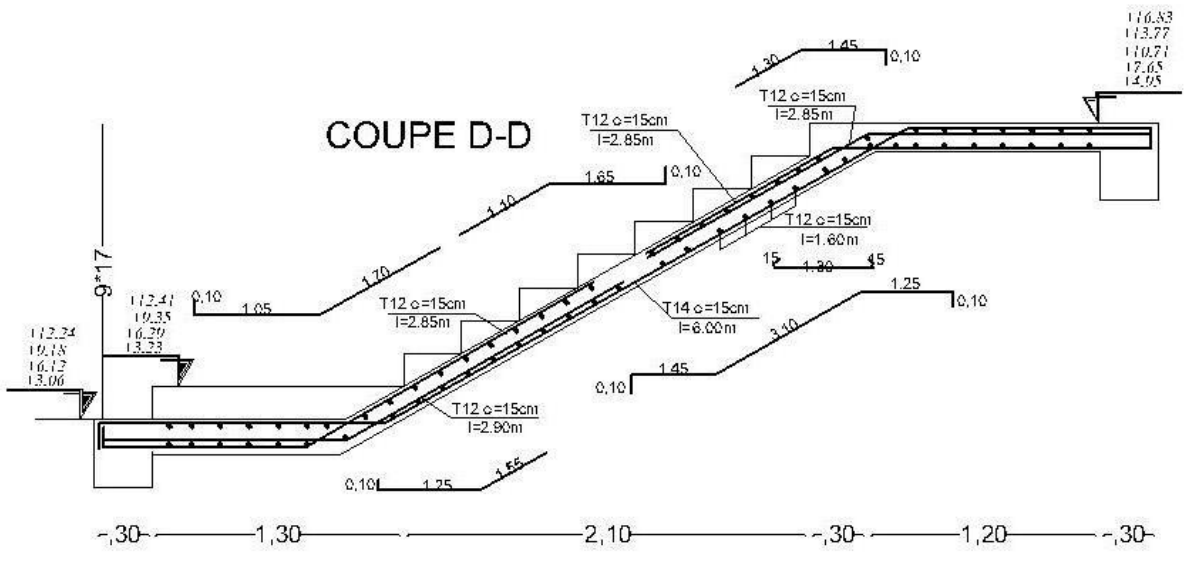

COUPE A-A

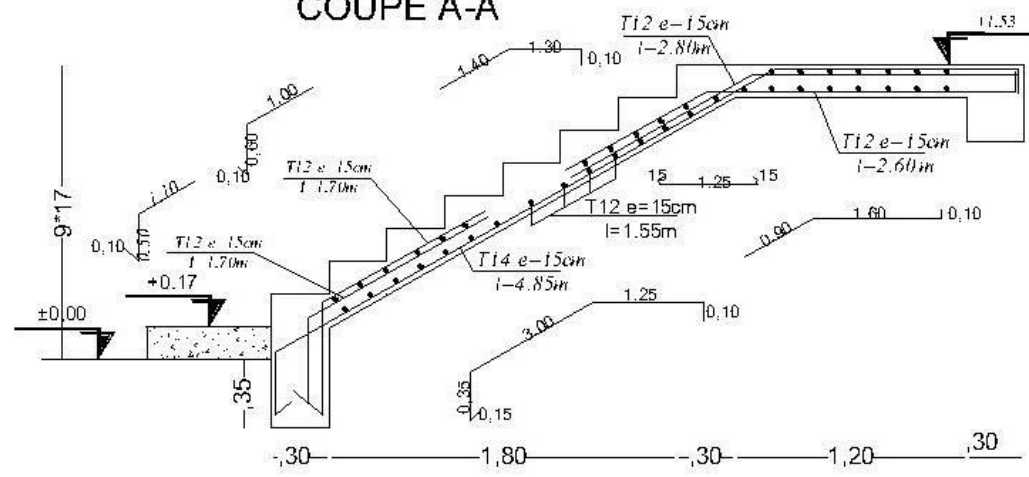

COUPE C-C

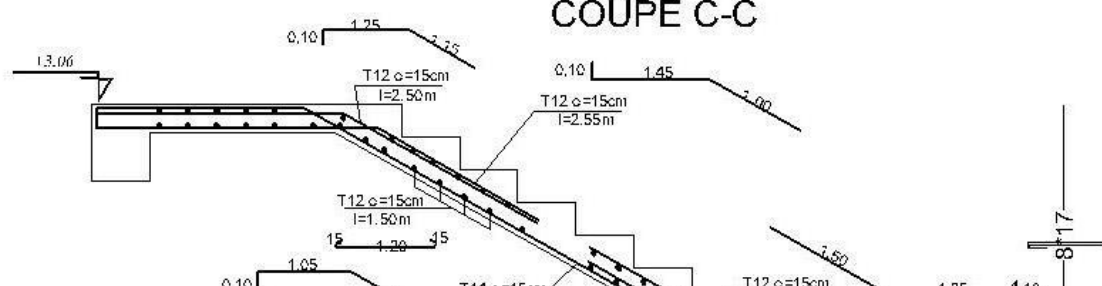

POUTRE

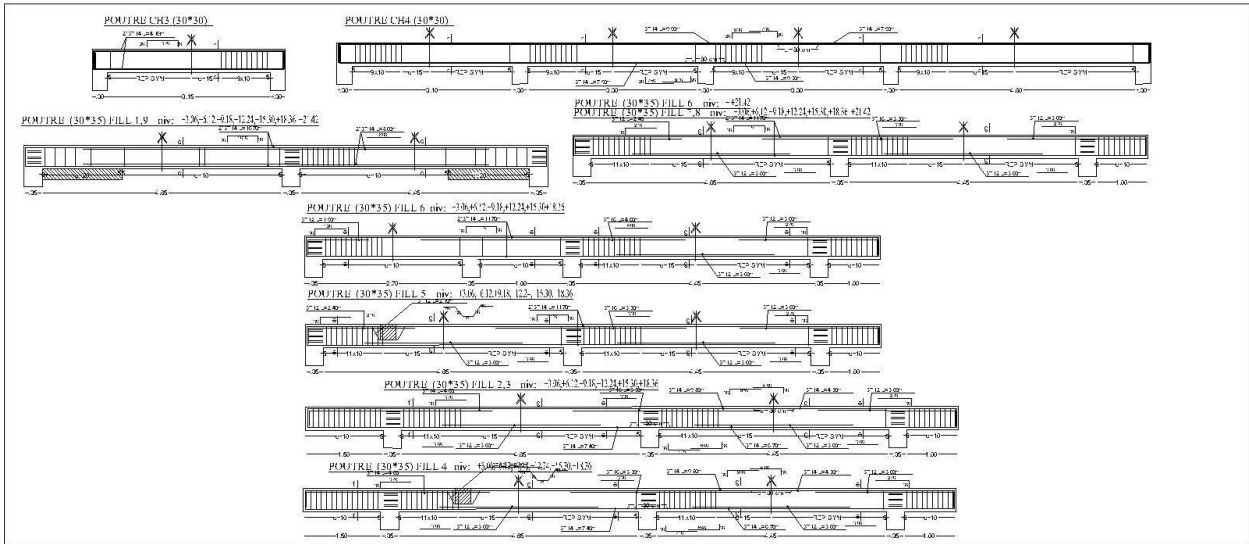
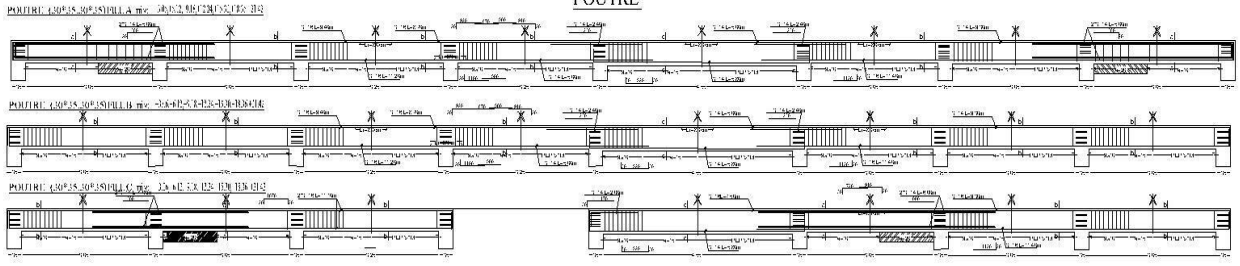

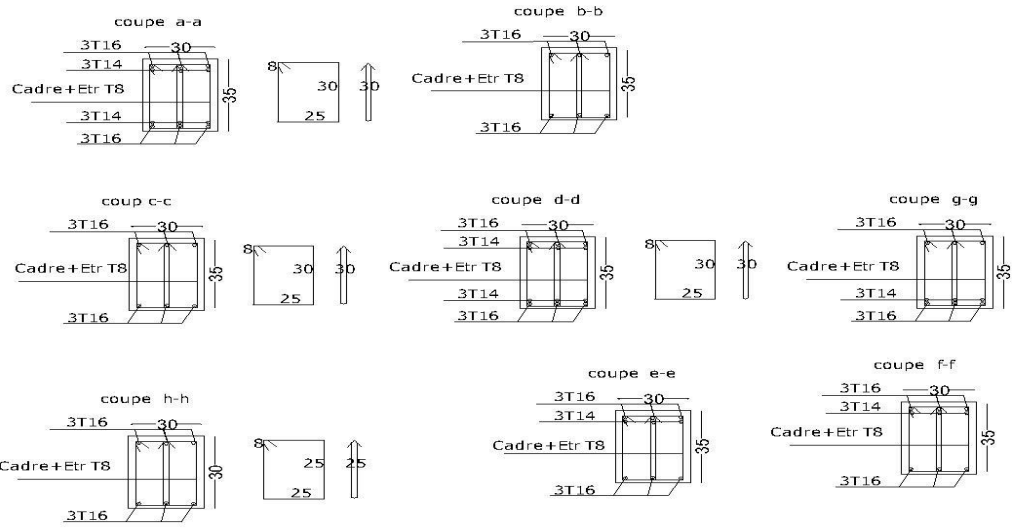

POUTRE CH1 (30*30)

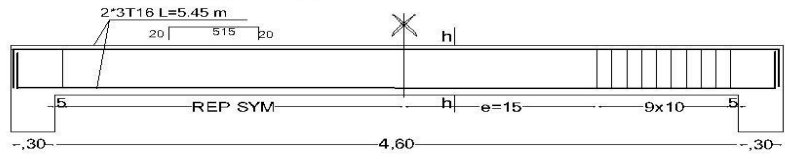

POUTRE CH2 (30*30)

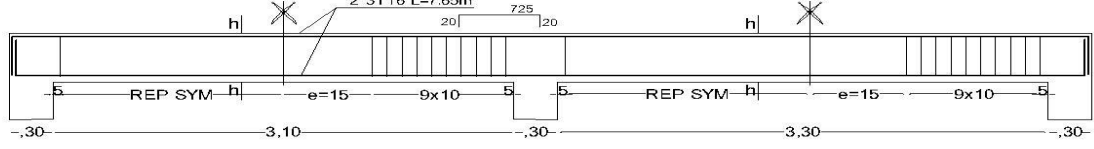

POUTRE NOYER (30x21)

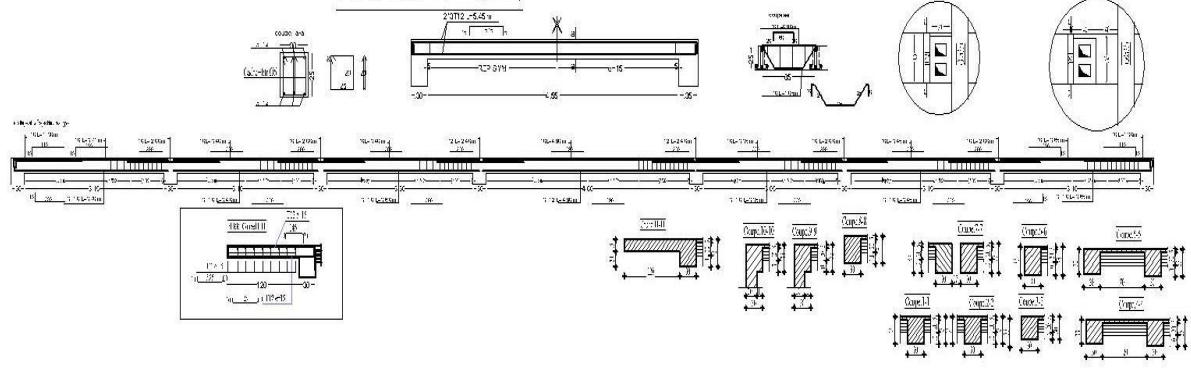

FERR- POTEAUX FERR- VOILES

